



FAMILY OWNED  
SINCE 1890

## Wildland Urban Interface Vehicle



Shown with Optional Equipment

Sutphen Wildland units are the perfect mix of form and function. These trucks are designed with a short overall length, and un-matched angles of approach and departure exceeding 20 degrees. This special attention to chassis design allows them to operate in the roughest of terrain, or on a busy highway. Capability for stationary high-volume pumping or pump and roll, you'll be ready for any size situation.

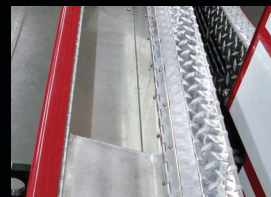

### APPARATUS BODY

**CONSTRUCTION:** Extruded aluminum with 3/16" aluminum plate interiors

**DOORS:** Roll up doors painted or satin finish, hinged doors optional

**HOSEBED:** Capacity for 1200' of 5", 500' of 2", 500' of 1 3/4"

**LADDERS:** Alco-Lite (1) 24' or 35' 2-section, (1) 14' Roof, (1) 10' Folding

**BOOSTER TANK:** 500 or 650 US Gallons, "L" shaped for low hose bed height

**AIR BOTTLE STORAGE:** Capacity for up to (4) air bottles stored in the fender wells and two left fender

**MISCELLANEOUS:** (2) 10' Hard suction hoses, 4" Scotchlite stripe, (1) Hosebed divider

### PUMP FEATURES

Hale of Waterous pumps available.  
1250-1500 gpm mid-ship mounted pump.

**STANDARD DISCHARGES:** (2) 2.5" Left, (1) 2.5" Right, (1) 2.5" Right Rear, (1) 3" Deck Gun

Side mount pump controls.

Multiple options for foam systems available.

Optional auxiliary pump for true pump and roll capabilities.

### BODY FEATURES

- High ground clearance for improved angle of approach of 19 degrees, and departure 20 degrees
- 169" wheelbase
- Over 160 Cu. ft. of useable compartment space
- 3/16" aluminum extrusions are stronger than fabricated bodies
- 3/16" door and body sides versus 1/8" if fabricated
- Removable rear treadplate fenders and fiberglass liners
- Heaviest rear body substructure in the industry
- Adjustable, non-painted, heavy-duty hosebed dividers
- Maintenance free compartment interiors, never needs painting
- Flip up rear step

# SUTPHEN Wildland Urban Interface Vehicle

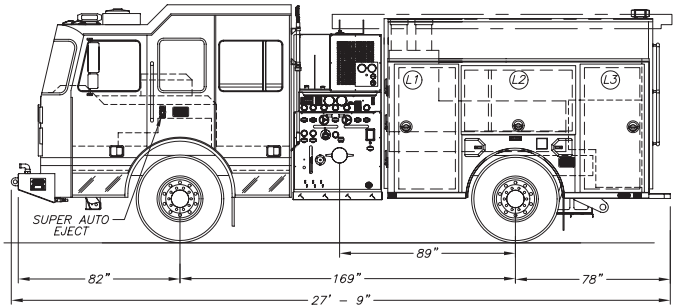
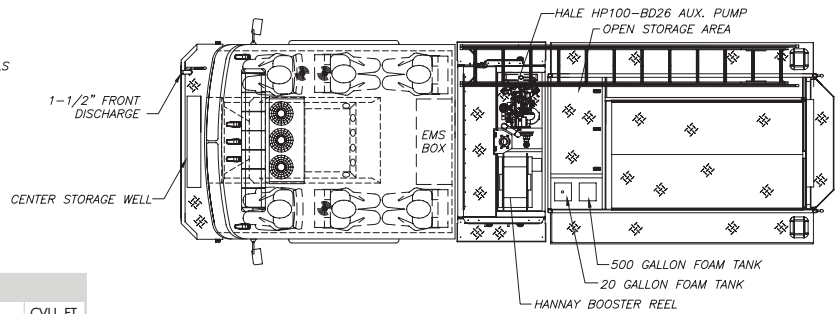
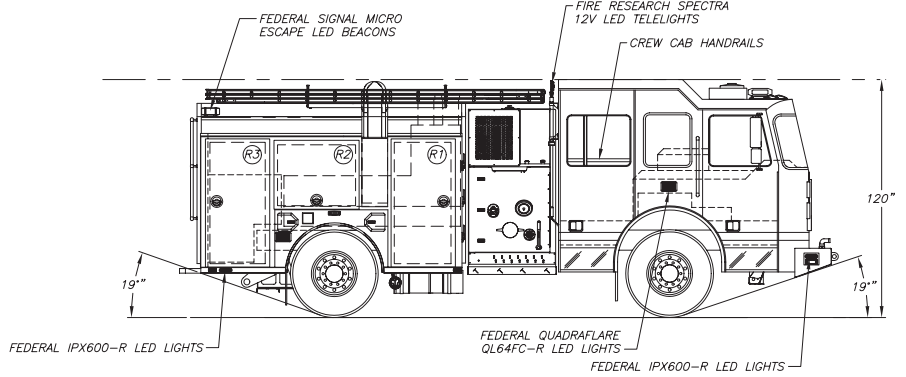
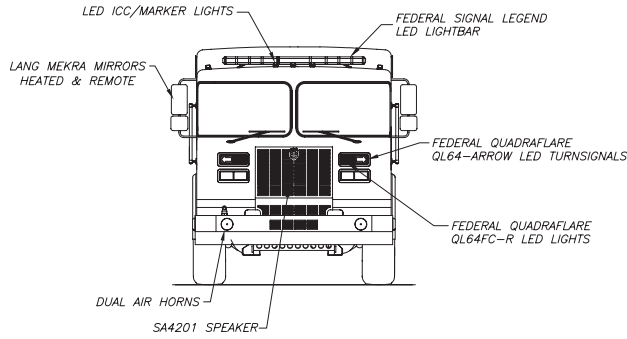
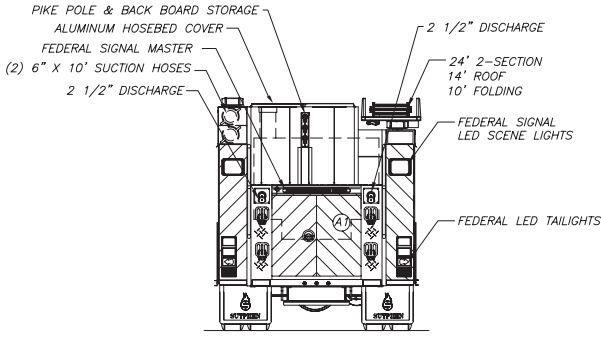

LEFT SIDE COMPARTMENTATION				
VOLUME	DOORS	OPENING DIMENSIONS	INSIDE DIMENSIONS	CU. FT.
L1	SINGLE	25 1/2"W x 62 3/4"H	33 1/2"W x 66"H x 14 1/2"DEEP UPPER 33 1/2"W x 30"H x 27 1/4"DEEP LOWER	27.6
L2	LIFT-UP	57 1/2"W x 32 1/4"H	61 1/2"W x 36 1/2"H x 14 1/2"D	16.6
L3	SINGLE	25 1/2"W x 62 3/4"H	33 1/2"W x 66"14 1/2"DEEP UPPER 33 1/2"W x 66"H x 27 1/4"DEEP LOWER	20.5

RIGHT SIDE COMPARTMENTATION				
VOLUME	DOORS	OPENING DIMENSIONS	INSIDE DIMENSIONS	CU. FT.
R1	SINGLE	25 1/2"W x 62 3/4"H	33 1/2"W x 66"H x 14 1/2"DEEP UPPER 33 1/2"W x 30"H x 27 1/4"DEEP LOWER	27.6
R2	LIFT-UP	57 1/2"W x 32 1/4"H	61 1/2"W x 36 1/2"H x 14 1/2"D	11.3
R3	SINGLE	25 1/2"W x 62 3/4"H	33 1/2"W x 66"14 1/2"DEEP UPPER 33 1/2"W x 66"H x 27 1/4"DEEP LOWER	27

REAR STEP COMPARTMENTS				
VOLUME	DOORS	OPENING DIMENSIONS	INSIDE DIMENSIONS	CU. FT.
R1	ROLL-UP	40"W x 39"H	40"W x 40"H x 37"DEEP UPPER 40"W x 40"H x 23"DEEP LOWER	31.5

TOTAL STORAGE: 162.1 CU. FT.



**SUTPHEN™**

**SUTPHEN CORPORATION** 6450 Eiterman Rd., Dublin, OH 43016

Tel: 614.889.1005 • Toll Free: 800.848.5860 • Fax: 614.889.0874

Web: [www.sutphen.com](http://www.sutphen.com) • E-mail: [sutphen@sutphencorp.com](mailto:sutphen@sutphencorp.com)



Wildland Urban Interface Vehicle 2018