

Left Side Compartmentation				
Compt	Doors	Opening Dimensions	Inside Dimensions	Volume
WxHxD				
L1	Roll Up	51x60	58x70xTransverse	101.1 CU FT
L2	Roll Up	39x34	46x44x22.25	27.2 CU FT
L3	Roll Up	43x60	50x70x22.25	47.1 CU FT
Right Side Compartmentation				
Compt	Doors	Opening Dimensions	Inside Dimensions	Volume
WxHxD				
R1	Roll Up	51x60	58x70xTransverse	101.1 CU FT
R2	Roll Up	39x34	46x44x22.25	27.2 CU FT
R3	Roll Up	43x60	50x70x22.25	47.1 CU FT
Rear Compartmentation				
Compt	Doors	Opening Dimensions	Inside Dimensions	Volume
WxHxD				
A1	Roll Up	40x48	46x58x94.25	145.5 CU FT
Total Volume				496.5 CU Ft

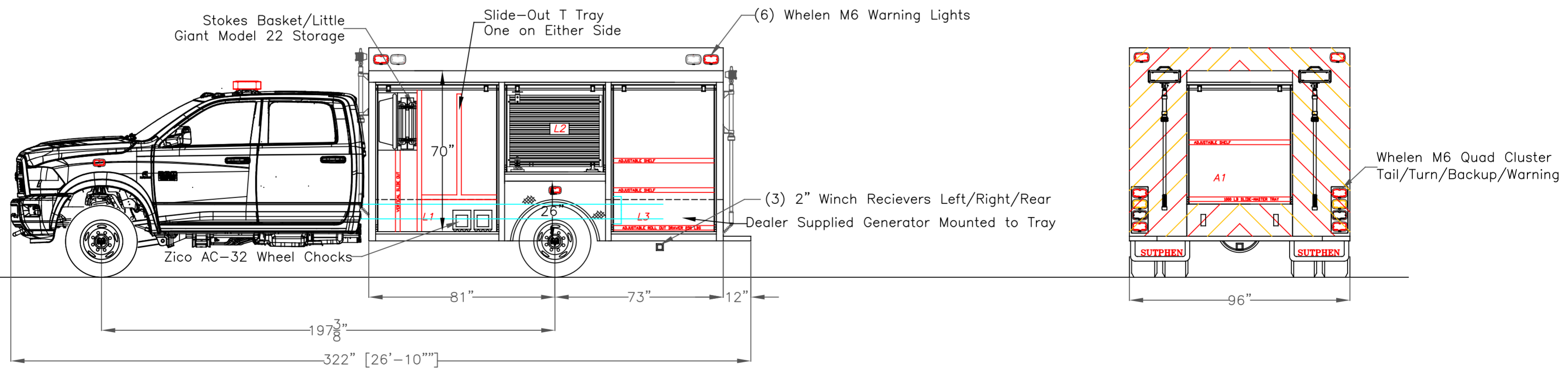

DIMENSIONS SHOWN ON THIS DRAWING ARE APPROXIMATE AND ARE SUBJECT TO MINOR DEVIATIONS DURING CONSTRUCTION. IN THE EVENT OF A DISCREPANCY BETWEEN THE SUTPHEN SPECIFICATIONS AND DRAWING, THE SUTPHEN SPECIFICATIONS SHALL PREVAIL. DRAWING IS FOR REFERENCE ONLY. SOME ITEMS PROPOSED MAY NOT BE SHOWN OR NOTED.	CUSTOMER APPROVAL						DRAWN BY: S.DORFMAN	SUTPHEN EAST 55 INNOVATION DRIVE LAKE ARIEL, PA 18436 1-866-776-2889 Whitesville Vol. Fire Dept. Whitesville, WV Mini-Rescue HS 6069
	NAME:						DATE:	
	TITLE:						6/2/17	
DATE:		A REV.	Updates to Reflect Change Order DESCRIPTION	SED BY	8/3/17 DATE	MFG. FACILITY: SUTPHEN EAST LAKE ARIEL, PA	DWG. NO.:	
THIS PRINT IS PROVIDED ON A RESTRICTED BASIS AND IS NOT TO BE USED IN ANY WAY DETRIMENTAL TO THE INTEREST OF SUTPHEN CORPORATION.								