

Left Side Compartmentation				
Compt	Doors	Opening Dimensions	Inside Dimensions	Volume
WxHxD				
L1	Roll Up	38x56	45x66x27.25/10.25	32.7 CU FT
L2	Roll Up	57x22	64x32x10.25	12.1 CU FT
L3	Roll Up	38x56	45x66x27.25/10.25	32.7 CU FT
Right Side Compartmentation				
Compt	Doors	Opening Dimensions	Inside Dimensions	Volume
R1	Roll Up	38x24	45x34x27.25	24.1 CU FT
R2	Roll Up	38x24	45x34x27.25	24.1 CU FT

Hale Qmax XS 1500 single stage
Water Tank Capacity 1500 gal

Total Volume	125.7 CU Ft
--------------	-------------

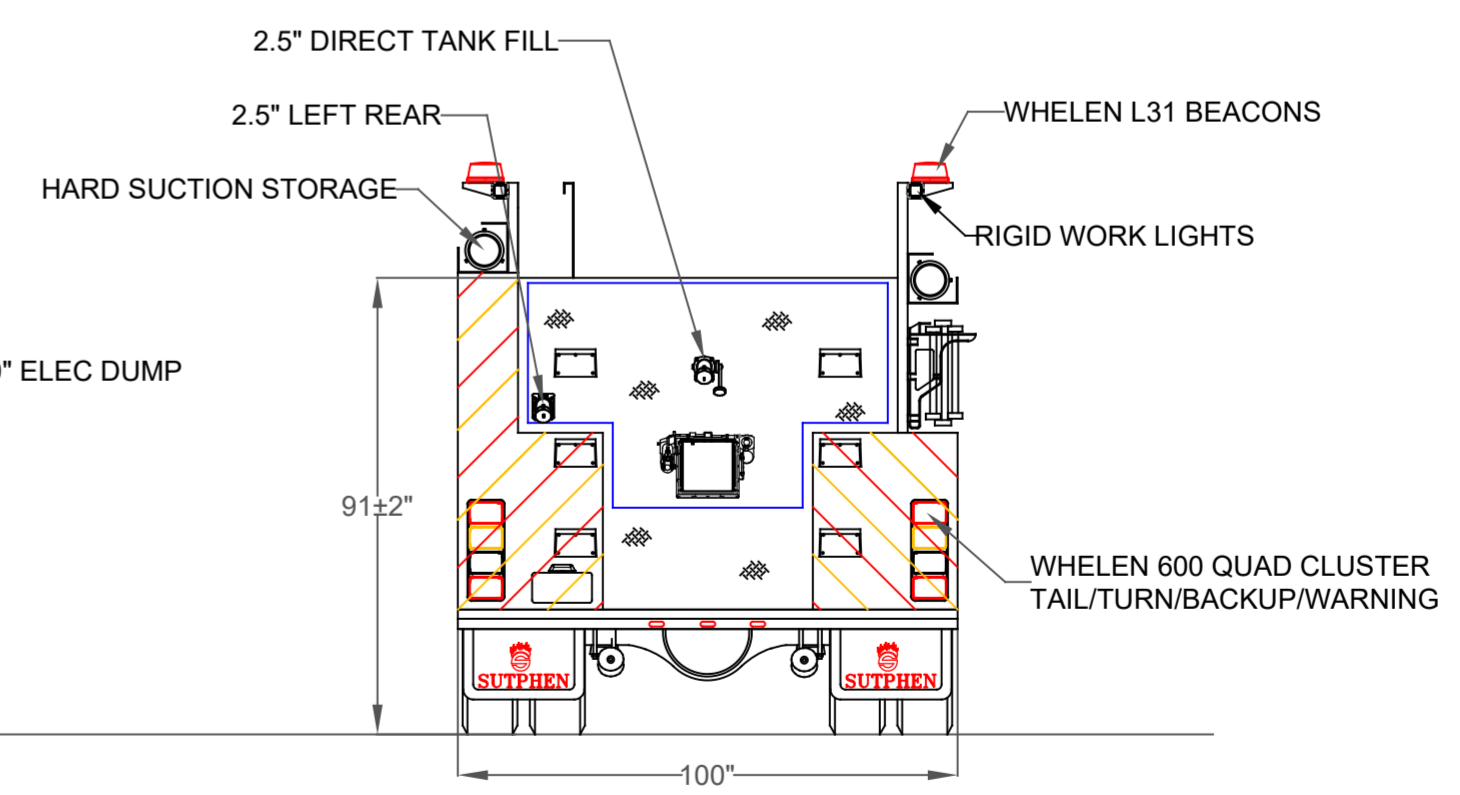
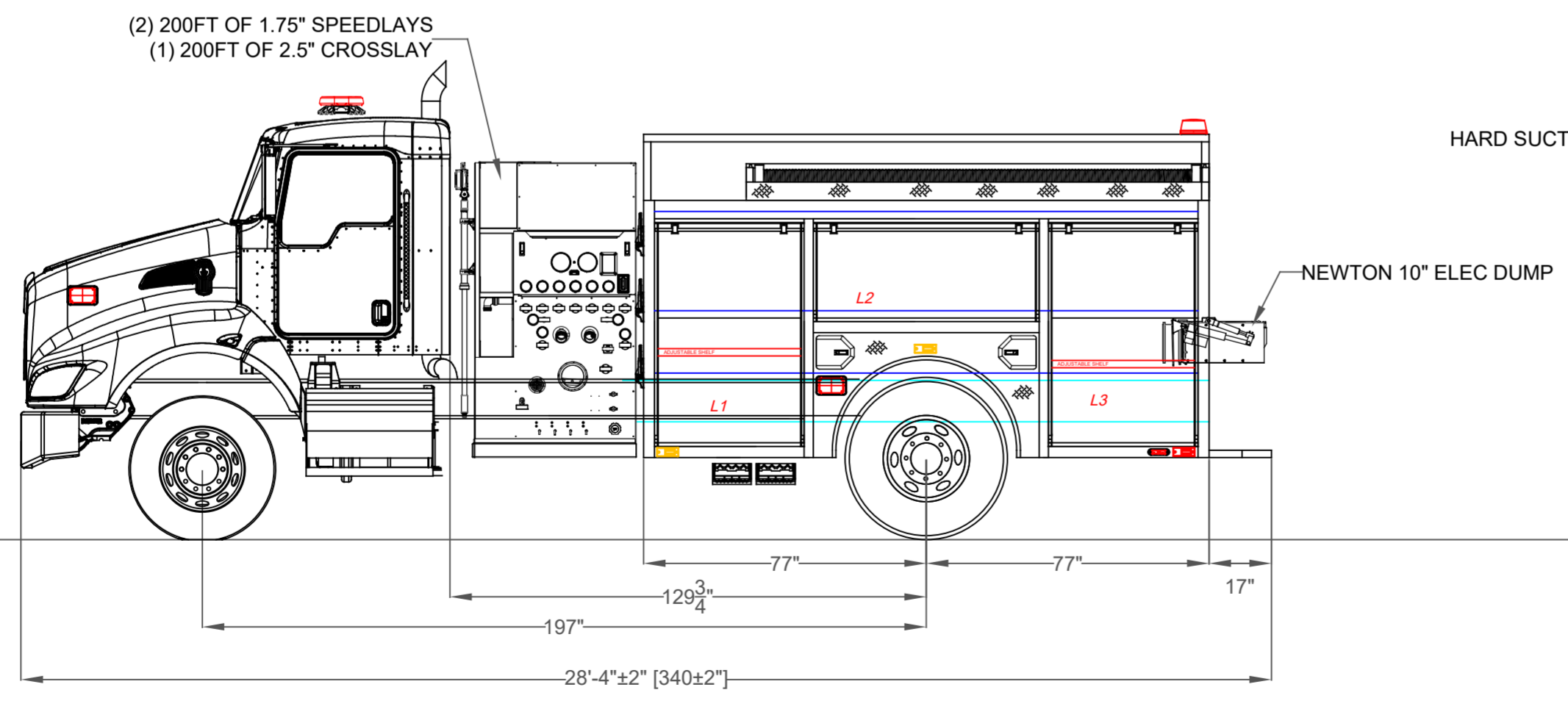

DIMENSIONS SHOWN ON THIS DRAWING ARE APPROXIMATE AND ARE SUBJECT TO MINOR DEVIATIONS DURING CONSTRUCTION.

IN THE EVENT OF A DISCREPANCY BETWEEN THE SUTPHEN SPECIFICATIONS AND DRAWING, THE SUTPHEN SPECIFICATIONS SHALL PREVAIL.

DRAWING IS FOR REFERENCE ONLY. SOME ITEMS PROPOSED MAY NOT BE SHOWN OR NOTED.

CUSTOMER APPROVAL

NAME: _____

TITLE: _____

DATE: _____

REV.	DESCRIPTION	BY	DATE

THIS PRINT IS PROVIDED ON A RESTRICTED BASIS AND IS NOT TO BE USED IN ANY WAY DETRIMENTAL TO THE INTEREST OF SUTPHEN CORPORATION.

DRAWN BY:
J. Gordon

DATE:
10/25/2018

MFG. FACILITY:
SUTPHEN EAST
LAKE ARIEL, PA

Southwest Marion Fire Protection District
Foxworth, MS

C5 Commercial Aluminum Pumper

DWG. NO.: HS 6440