

Left Side Compartmentation				
Compt	Doors	Opening Dimensions	Inside Dimensions	Volume
WxHxD				
L1	Hinged	43x26	50x36x24.25	25.3 CU FT
L2	Hinged	28x26	34x36x24.25	17.7 CU FT
L3	Hinged	23x26	29x36x24.25	15.2 CU FT
Right Side Compartmentation				
Compt	Doors	Opening Dimensions	Inside Dimensions	Volume
R1	Hinged	43x26	50x36x24.25	25.3 CU FT
R2	Hinged	28x26	34x36x24.25	17.7 CU FT
R3	Hinged	23x26	29x36x24.25	15.2 CU FT

Hale Qflo 1250 single stage
Water Tank Capacity 2000 gal

Total Volume
116.2 CU FT

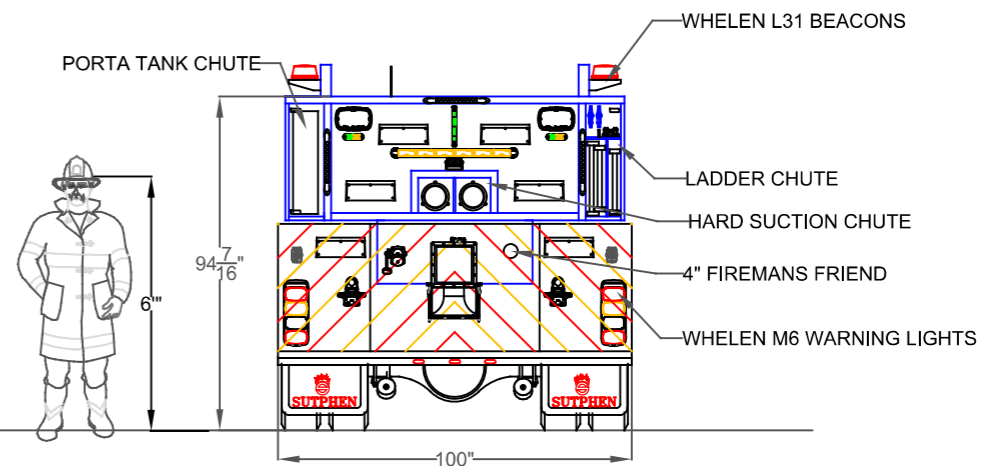
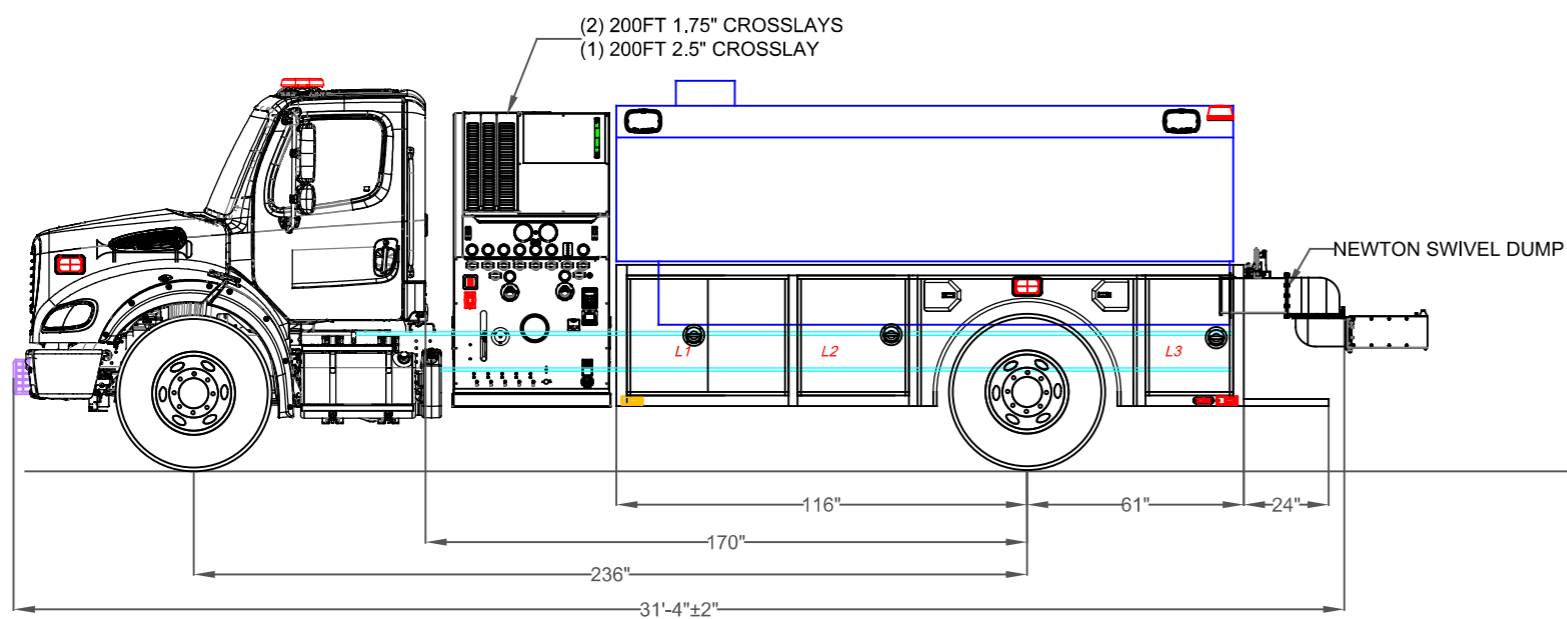

DIMENSIONS SHOWN ON THIS DRAWING ARE APPROXIMATE AND ARE SUBJECT TO MINOR DEVIATIONS DURING CONSTRUCTION.

IN THE EVENT OF A DISCREPANCY BETWEEN THE SUTPHEN SPECIFICATIONS AND DRAWING, THE SUTPHEN SPECIFICATIONS SHALL PREVAIL.

DRAWING IS FOR REFERENCE ONLY. SOME ITEMS PROPOSED MAY NOT BE SHOWN OR NOTED.

CUSTOMER APPROVAL

NAME: _____

TITLE: _____

DATE: _____

REV.	DESCRIPTION	BY	DATE

THIS PRINT IS PROVIDED ON A RESTRICTED BASIS AND IS NOT TO BE USED IN ANY WAY DETRIMENTAL TO THE INTEREST OF SUTPHEN CORPORATION.

DRAWN BY: J. GORDON

DATE: 02/02/2021

MFG. FACILITY: SUTPHEN EAST LAKE ARIEL, PA

DWG. NO.: HS 7039

SUTPHEN EAST
55 INNOVATION DRIVE
LAKE ARIEL, PA
1-844-776-2889

VALLEY FIRE DISTRICT
PENINSULA, OH

COMMERCIAL ALUMINUM WETSIDE TANKER