

| COMP | DOORS   | OPENING DIMENSIONS | INSIDE DIMENSIONS        | VOLUME       |
|------|---------|--------------------|--------------------------|--------------|
| L1   | ROLL-UP | 25.5"W X 57.4"H    | 31.1"W X 65"H X 27.3"D   | 29.4 CU. FT. |
| L2   | ROLL-UP | 57.5"W X 58.2"H    | 61.6"W X 36.8"H X 27.3"D | 26.8 CU. FT. |
| L3   | ROLL-UP | 50.5"W X 57.4"H    | 53.4"W X 65"H X 27.3"D   | 50.3 CU. FT. |

| COMP | DOORS  | OPENING DIMENSIONS | INSIDE DIMENSIONS      | VOLUME       |
|------|--------|--------------------|------------------------|--------------|
| R1   | SINGLE | 25.5"W X 25.4"H    | 31.1"W X 33"H X 27.3"D | 16.2 CU. FT. |
| R3   | DOUBLE | 48.5"W X 25.4"H    | 52.4"W X 33"H X 27.3"D | 27.3 CU. FT. |

| COMP | DOORS  | OPENING DIMENSIONS | INSIDE DIMENSIONS  | VOLUME       |
|------|--------|--------------------|--------------------|--------------|
| A1   | DOUBLE | 37.5"W X 32.8"H    | 40"H X 40"W X 31"D | 28.7 CU. FT. |

TOTAL: 182.5 CU.FT.

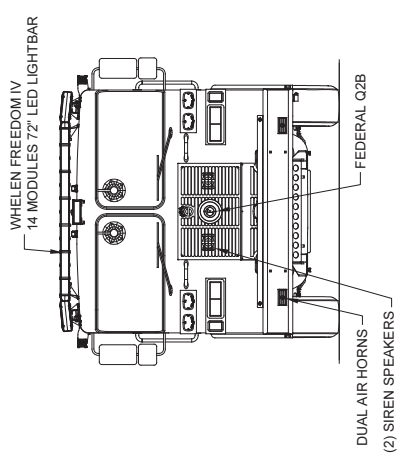

**CUSTOMER APPROVAL**

NAME: \_\_\_\_\_

TITLE: \_\_\_\_\_

DATE: \_\_\_\_\_

**SUTPHEN**

ROCKDALE COUNTY FIRE DEPARTMENT

ROCKDALE COUNTY

CUSTOM PLUMBER - PA-09 BODY

DWG. NO. HS-5335-26

---

DIMENSIONS SHOWN ON THIS DRAWING ARE APPROXIMATE AND ARE SUBJECT TO MINOR DEVIATIONS DURING CONSTRUCTION.

IN THE EVENT OF A DISCREPANCY BETWEEN THE SUTPHEN SPECIFICATIONS AND DRAWING, THE SUTPHEN SPECIFICATIONS SHALL PREVAIL.

DRAWING IS FOR REFERENCE ONLY. SOME ITEMS PROPOSED MAY NOT BE SHOWN OR NOTED.

COMPONENT REPORT UPDATE / SHOWED OUTLET LOCATIONS

REV-A SHOP ORDER

DESCRIPTION: THIS PRINT IS PROVIDED ON A RESTRICTED BASIS AND IS NOT TO BE USED IN ANY WAY DETRIMENTAL TO THE INTEREST OF SUTPHEN CORPORATION.

---

| REV | DESCRIPTION   | DATE     | BY | DATE | MIC | DATE     | BY      |
|-----|---|----------|----|------|-----|----------|---------|
| A   | REV-A SHOP ORDER  | 08/23/18 | JM |      | MIC | 03/14/19 | JMORGAN |
| B   | REV-B SHOP ORDER  | 10/16/18 | JM |      | MIC | 06/03/19 |         |
| C   | COMPONENT REPORT UPDATE / SHOWED OUTLET LOCATIONS                           | 07/30/18 | JM |      | MIC |          |         |
| D   | COMPONENT REPORT UPDATE / UPDATE LOCATION FOR FRC REMOTE WATER LEVEL GAUGES |          |    |      |     |          |         |