

- LADDER CHUTE**
- (1) X 8' ATTIC FOLD
 - (1) X BBOARD STOR
 - (1) X PIKE TUBE
 - (1) X 24' 2-SECT.
 - (2) X 16' ROOF
 - (1) X 18' ROOF
 - (1) X 35' 2-SECT.

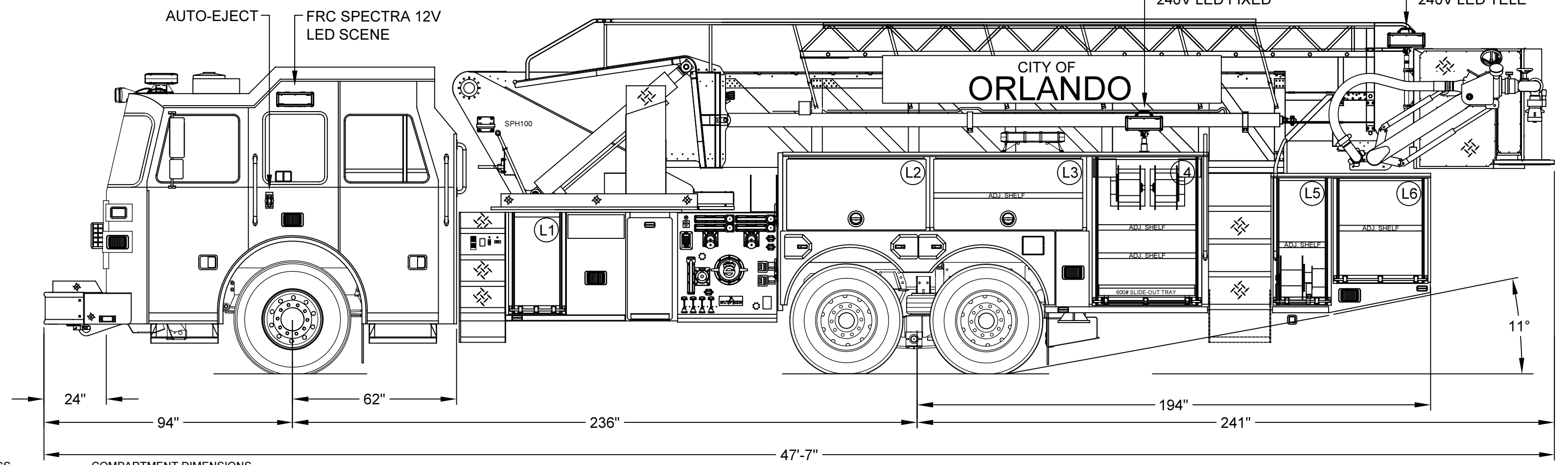
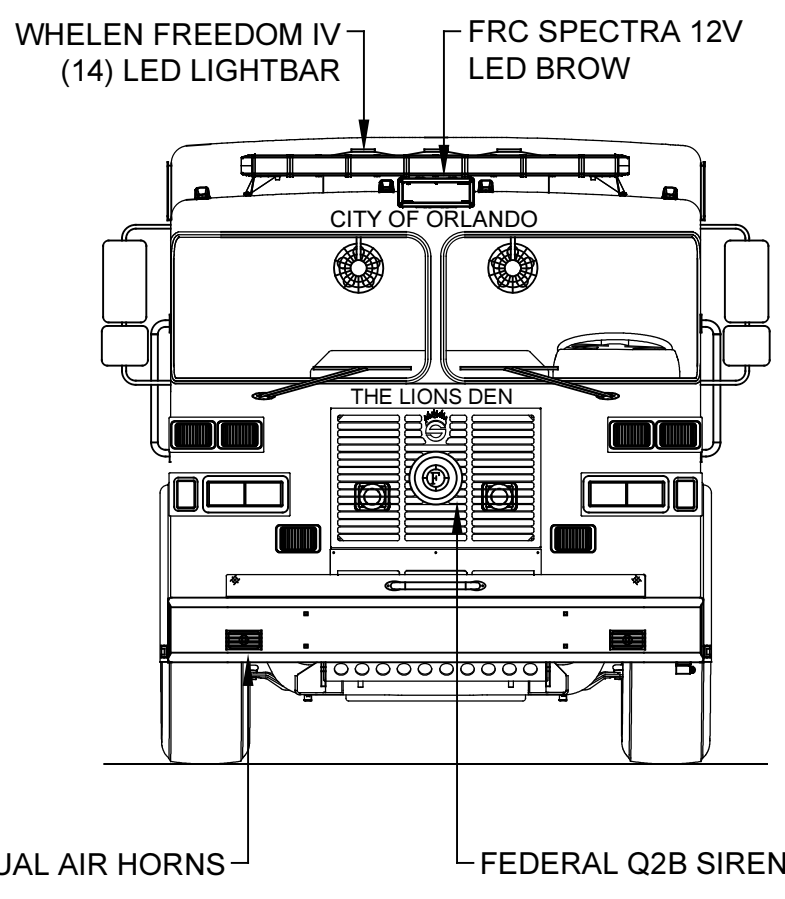
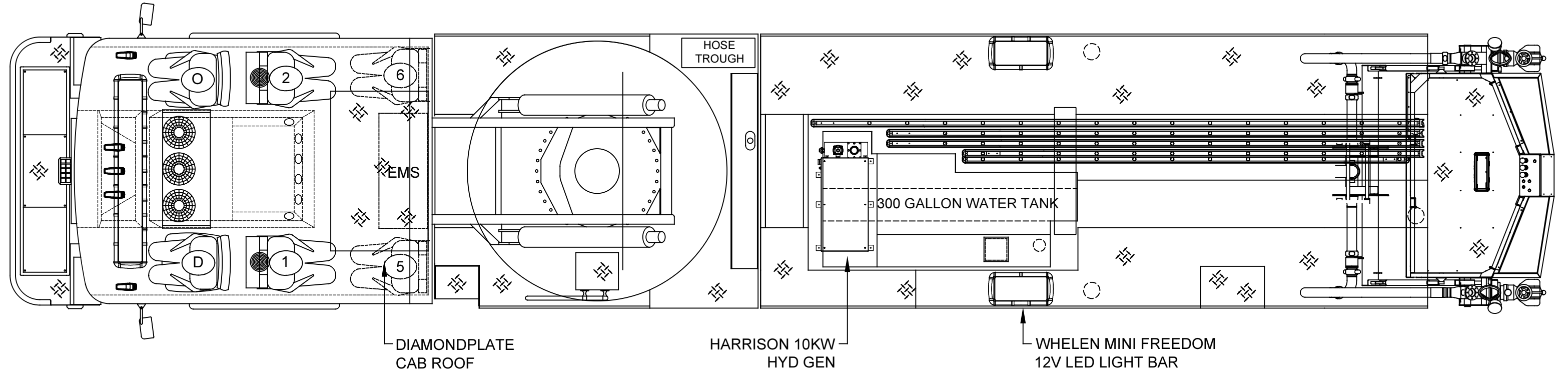
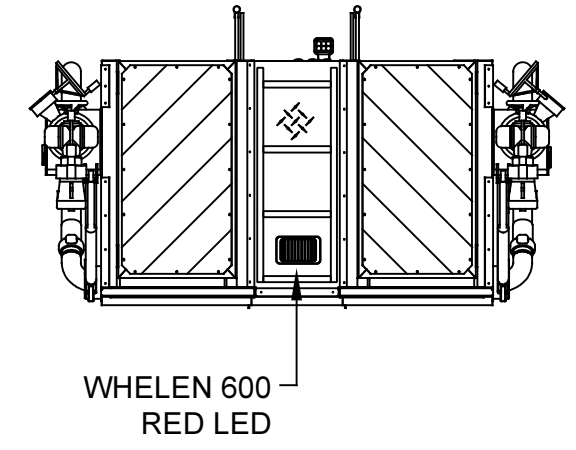
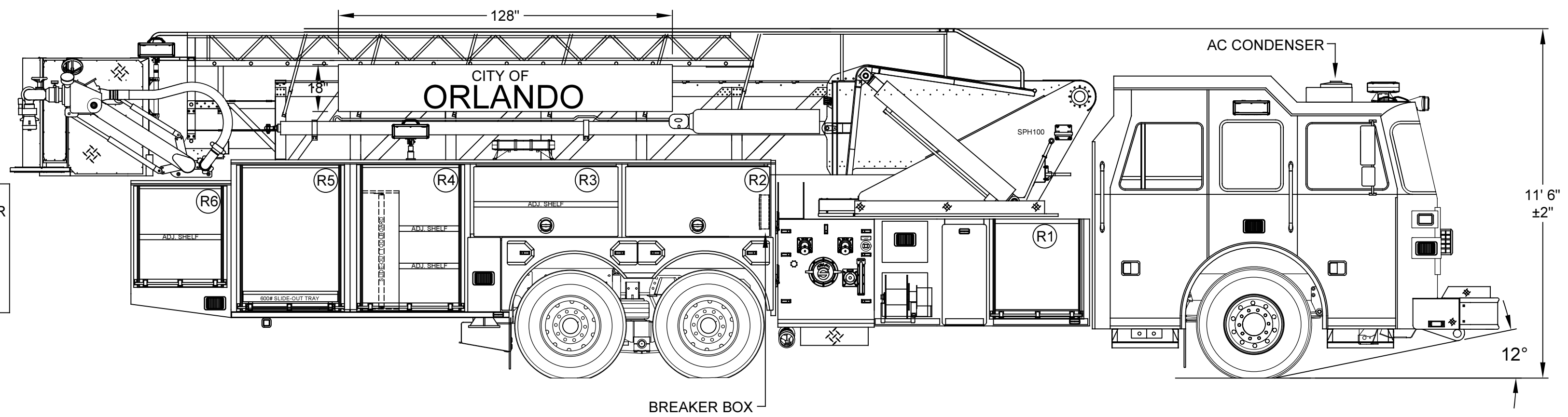

| DOOR OPENINGS | | | COMPARTMENT DIMENSIONS | | |
|---------------|--------|--------|------------------------|--------|--------|
| COMP.T. | HEIGHT | WIDTH | HEIGHT | WIDTH | DEPTH |
| L1 | 31 1/2 | 13 1/2 | 38 1/2 | 20 1/4 | 20 1/4 |
| L2 | 23 | 33 1/4 | 27 1/2 | 58 | 12 1/8 |
| L3 | 23 | 90 1/4 | 27 1/2 | 58 | 12 1/8 |
| L4 | 48 1/2 | 38 3/4 | 56 1/2 | 45 3/4 | 26 1/2 |
| L5 | 40 1/2 | 15 1/8 | 48 1/2 | 22 | 26 1/2 |
| L6 | 32 1/8 | 30 7/8 | 40 1/8 | 34 3/4 | 26 1/2 |

| DOOR OPENINGS | | | COMPARTMENT DIMENSIONS | | |
|---------------|--------|--------|------------------------|--------|--------|
| COMP.T. | HEIGHT | WIDTH | HEIGHT | WIDTH | DEPTH |
| R1 | 31 1/2 | 33 1/2 | 38 1/2 | 40 | 27 1/2 |
| R2 | 23 | 33 1/4 | 27 1/2 | 58 | 26 1/2 |
| R3 | 23 | 90 1/4 | 27 1/2 | 58 | 26 1/2 |
| R4 | 48 1/2 | 38 3/4 | 56 1/2 | 45 3/4 | 26 1/2 |
| R5 | 48 1/2 | 38 3/4 | 56 1/2 | 45 3/4 | 26 1/2 |
| R6 | 32 1/8 | 30 7/8 | 40 1/8 | 34 3/4 | 26 1/2 |

TOTAL COMPARTMENT VOLUME- 331 CU FT.

| DOOR OPENINGS | | | COMPARTMENT DIMENSIONS | | | |
|---------------|--------|--------|------------------------|-------|-------|--------|
| COMP.T. | HEIGHT | WIDTH | HEIGHT | WIDTH | DEPTH | VOLUME |
| A1 | 9 1/8 | 24 1/2 | 9 7/8 | 26 | 88 | 13.1 |
| A2 | - | - | 31 | 16 | 127 | 36.5 |

DIMENSIONS SHOWN ON THIS DRAWING ARE APPROXIMATE AND ARE SUBJECT TO MINOR DEVIATIONS DURING CONSTRUCTION.

IN THE EVENT OF A DISCREPANCY BETWEEN THE SUTPHEN SPECIFICATIONS AND DRAWING, THE SUTPHEN SPECIFICATIONS SHALL PREVAIL.

DRAWING IS FOR REFERENCE ONLY. SOME ITEMS PROPOSED MAY NOT BE SHOWN OR NOTED.

CUSTOMER APPROVAL

NAME: _____

TITLE: _____

DATE: _____

| REV. | DESCRIPTION | BY | DATE |
|------|-----------------------------------------------------------------|----|----------|
| D | POST-PRODUCTION REVISION TO REFLECT FINAL PRODUCT | RM | 04/10/18 |
| C | CLARIFICATION MADE THAT ONLY L4 SHELVES ARE TO BE 3/8" MATERIAL | RM | 02/05/18 |
| B | INTERIOR CAB DOOR MATERIAL CHANGED BACK TO REFLEXITE #L2 | RM | 02/02/18 |
| A | REV-A SHOP ORDER | RM | 10/13/17 |

THIS PRINT IS PROVIDED ON A RESTRICTED BASIS AND IS NOT TO BE USED IN ANY WAY DETRIMENTAL TO THE INTEREST OF SUTPHEN CORPORATION.

| | |
|----------------|-----------|
| DRAWN BY: | R. MILLER |
| DATE: | 08/24/17 |
| MFG. FACILITY: | DUBLIN |

ORLANDO FIRE DEPARTMENT
ORLANDO, FL

SPH100 AERIAL PLATFORM

DWG. NO.: HS-6140