

LEFT SIDE COMPARTMENTATION				
COMPT	DOORS	OPENING DIMENSIONS	INSIDE DIMENSIONS	VOLUME
L1		35 1/2" w X 62 3/4" h	43" w X 66" h X 27 1/4" d	40 CU. FT.
L2		57 1/2" w X 32 1/4" h	61 1/2" w X 36 1/2" h X 27 1/4" d	30 CU. FT.
L3		48 1/2" w X 62 3/4" h	53 1/2" w X 66" h X 27 1/4" d	55 CU. FT.

RIGHT SIDE COMPARTMENTATION				
COMPT	DOORS	OPENING DIMENSIONS	INSIDE DIMENSIONS	VOLUME
R1		35 1/2" w X 62 3/4" h	31 1/2" w X 66" h X 27 1/4" d (10 1/2" d upper)	26 CU. FT.
R2		57 1/2" w X 32 1/4" h	61 1/2" w X 36 1/2" h X 10 1/2" d	13 CU. FT.
R3		48 1/2" w X 62 3/4" h	53 1/2" w X 66" h X 27 1/4" d (10 1/2" d upper)	43 CU. FT.

REAR STEP COMPARTMENTS				
COMPT	DOORS	OPENING DIMENSIONS	INSIDE DIMENSIONS	VOLUME
A1	ROLL-UP	37 1/2" w X 31" h	40" h X 40" w X 30 1/2" d	27 CU. FT.

TOTAL: 234 CU. FT.

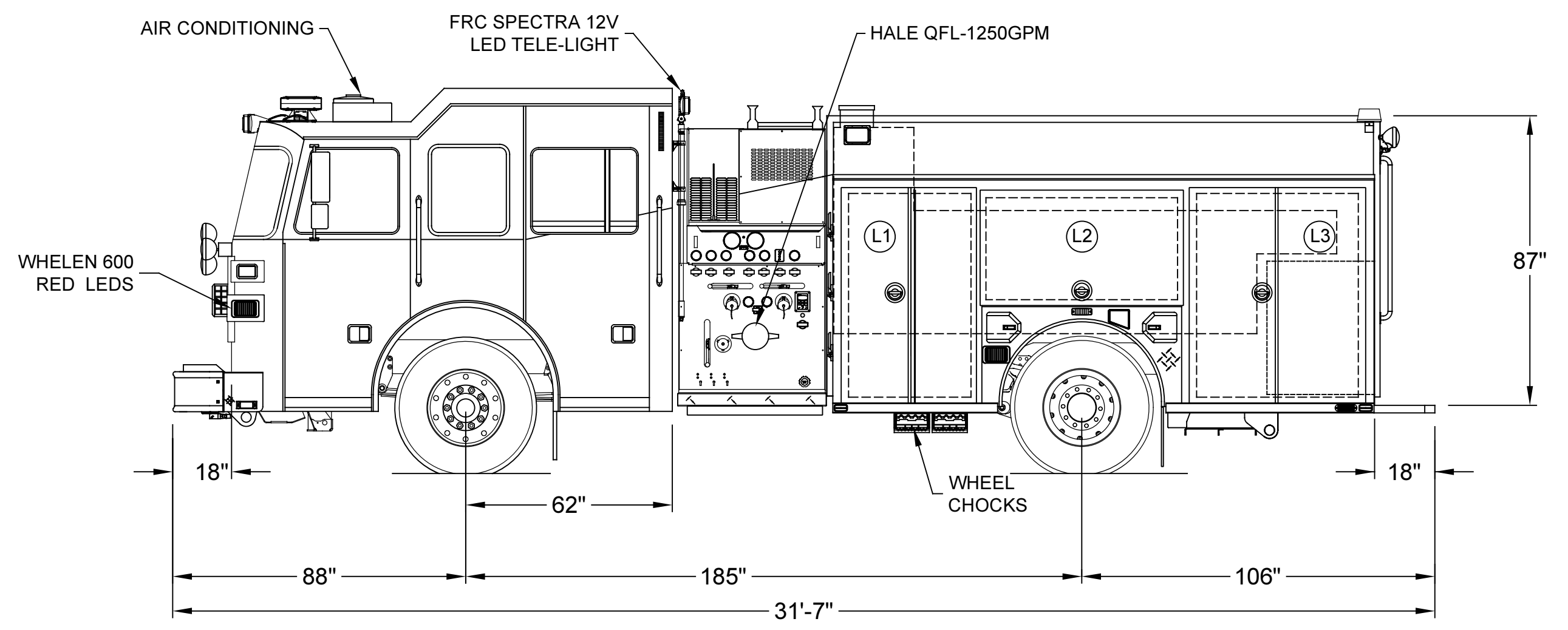
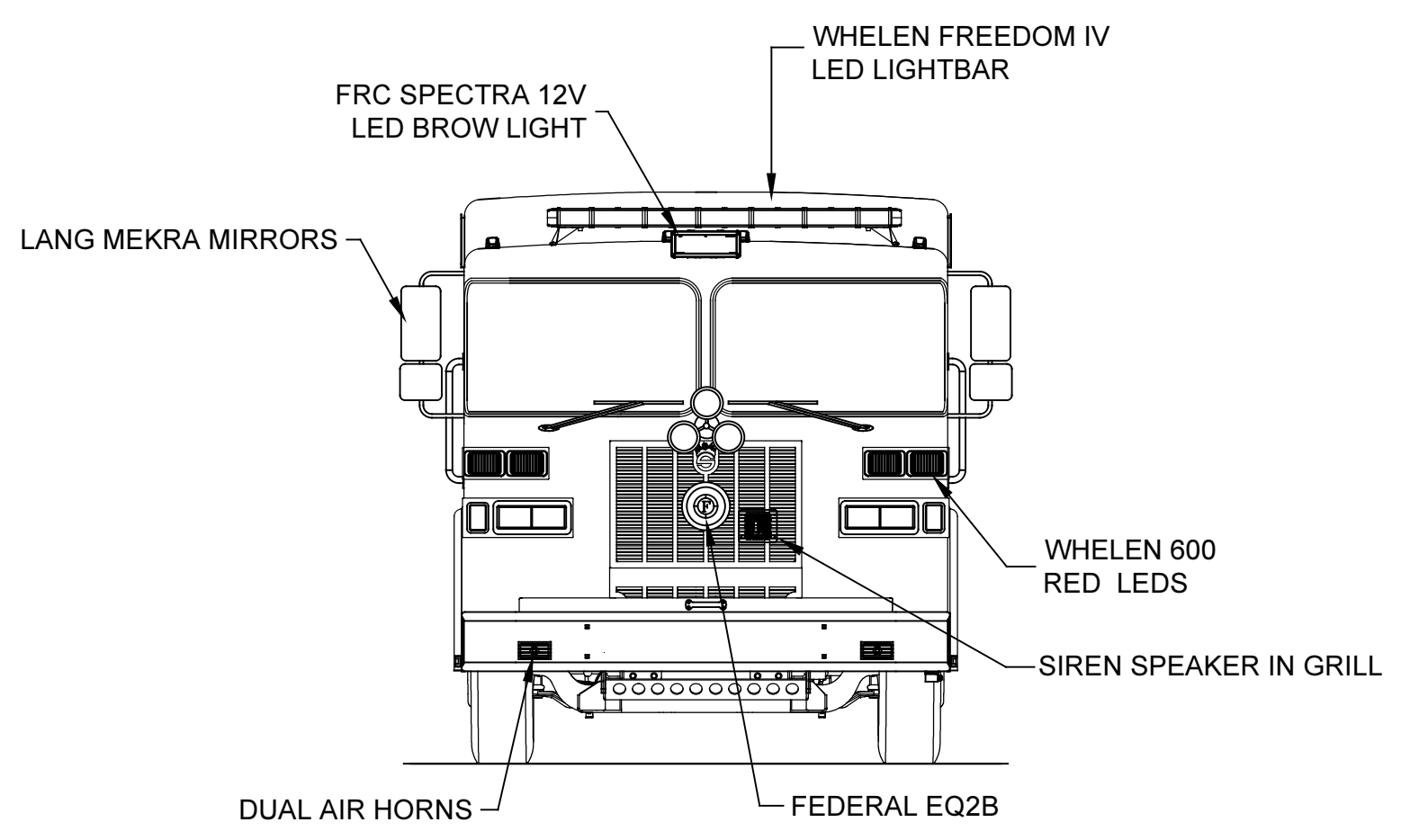
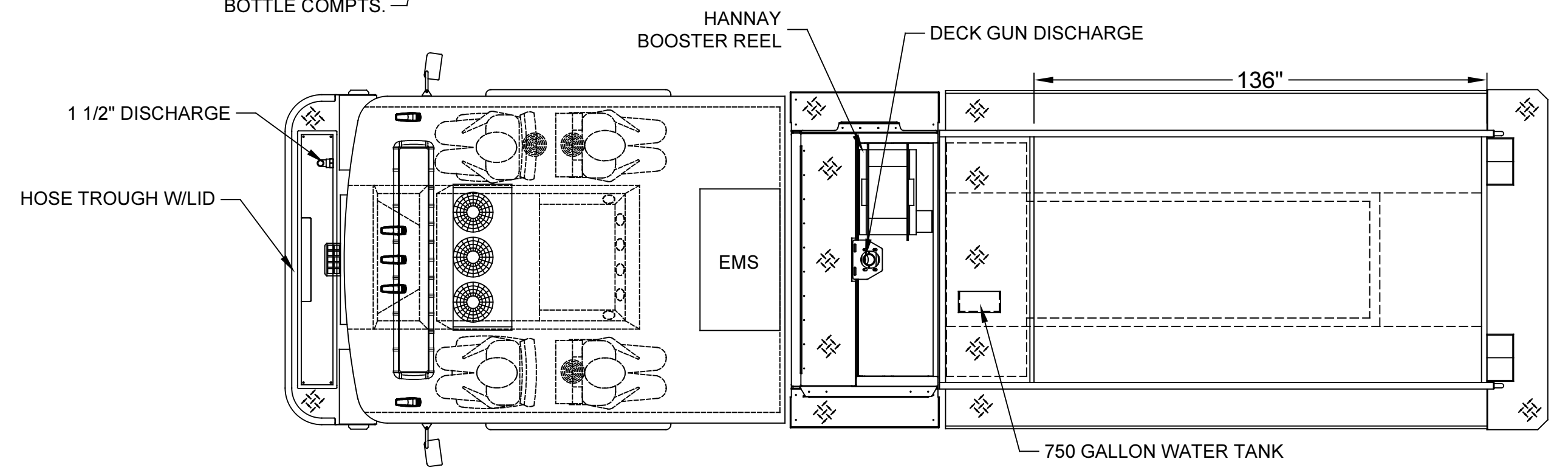

DIMENSIONS SHOWN ON THIS DRAWING ARE APPROXIMATE AND ARE SUBJECT TO MINOR DEVIATIONS DURING CONSTRUCTION.

IN THE EVENT OF A DISCREPANCY BETWEEN THE SUTPHEN SPECIFICATIONS AND DRAWING, THE SUTPHEN SPECIFICATIONS SHALL PREVAIL.

DRAWING IS FOR REFERENCE ONLY. SOME ITEMS PROPOSED MAY NOT BE SHOWN OR NOTED.

CUSTOMER APPROVAL

NAME: _____

TITLE: _____

DATE: _____

REV.	DESCRIPTION	BY	DATE
B	UPDATE-COMPONENT-REPORT	MJC	4/10/18
A	AFTER-PRE-CON	MJC	7/28/17

THIS PRINT IS PROVIDED ON A RESTRICTED BASIS AND IS NOT TO BE USED IN ANY WAY DETRIMENTAL TO THE INTEREST OF SUTPHEN CORPORATION.

DRAWN BY: HARLEY

DATE: 2/6/17

MFG. FACILITY: DUBLIN

SUTPHEN

PELL CITY FIRE DEPARTMENT
PELL CITY, AL

CUSTOM PUMPER

DWG. NO.: HS-6096