

LEFT SIDE COMPARTMENTATION				
COMPT	DOORS	OPENING DIMENSIONS	INSIDE DIMENSIONS	VOLUME
L1	ROLL-UP	50" w X 56 7/8" h	56 1/2" w X 66" h X 27 1/4" d	55 CU. FT.
L2	ROLL-UP	57" w X 27 5/8" h	61 1/2" w X 36 1/2" h X 27 1/4" d	35 CU. FT.
L3	ROLL-UP	50" w X 56 7/8" h	53 1/2" w X 66" h X 27 1/4" d	55 CU. FT.

RIGHT SIDE COMPARTMENTATION				
COMPT	DOORS	OPENING DIMENSIONS	INSIDE DIMENSIONS	VOLUME
R1	ROLL-UP	50" w X 50 7/8" h	56 1/2" w X 66" h X 27 1/4" d	43 CU. FT. 10 1/2" DEEP UPPER
R2	ROLL-UP	57" w X 21 5/8" h	61 1/2" w X 36 1/2" h X 10 1/2" d	13 CU. FT.
R3	ROLL-UP	50" w X 50 7/8" h	53 1/2" w X 66" h X 27 1/4" d	43 CU. FT. 10 1/2" DEEP UPPER

REAR STEP COMPARTMENTS				
COMPT	DOORS	OPENING DIMENSIONS	INSIDE DIMENSIONS	VOLUME
A1	ROLL-UP	37 1/2" w X 46" h	56" h X 40" w X 30 1/2" d	39 CU. FT.

TOTAL STORAGE: 283 CU.FT.

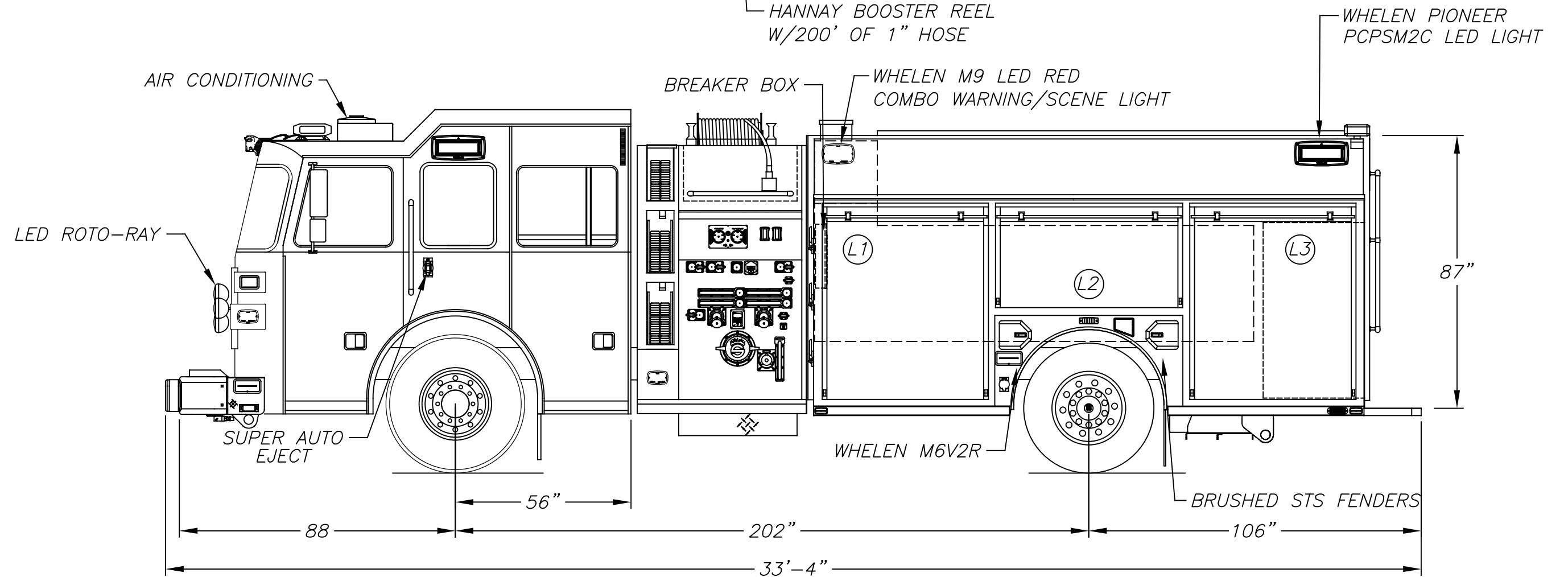
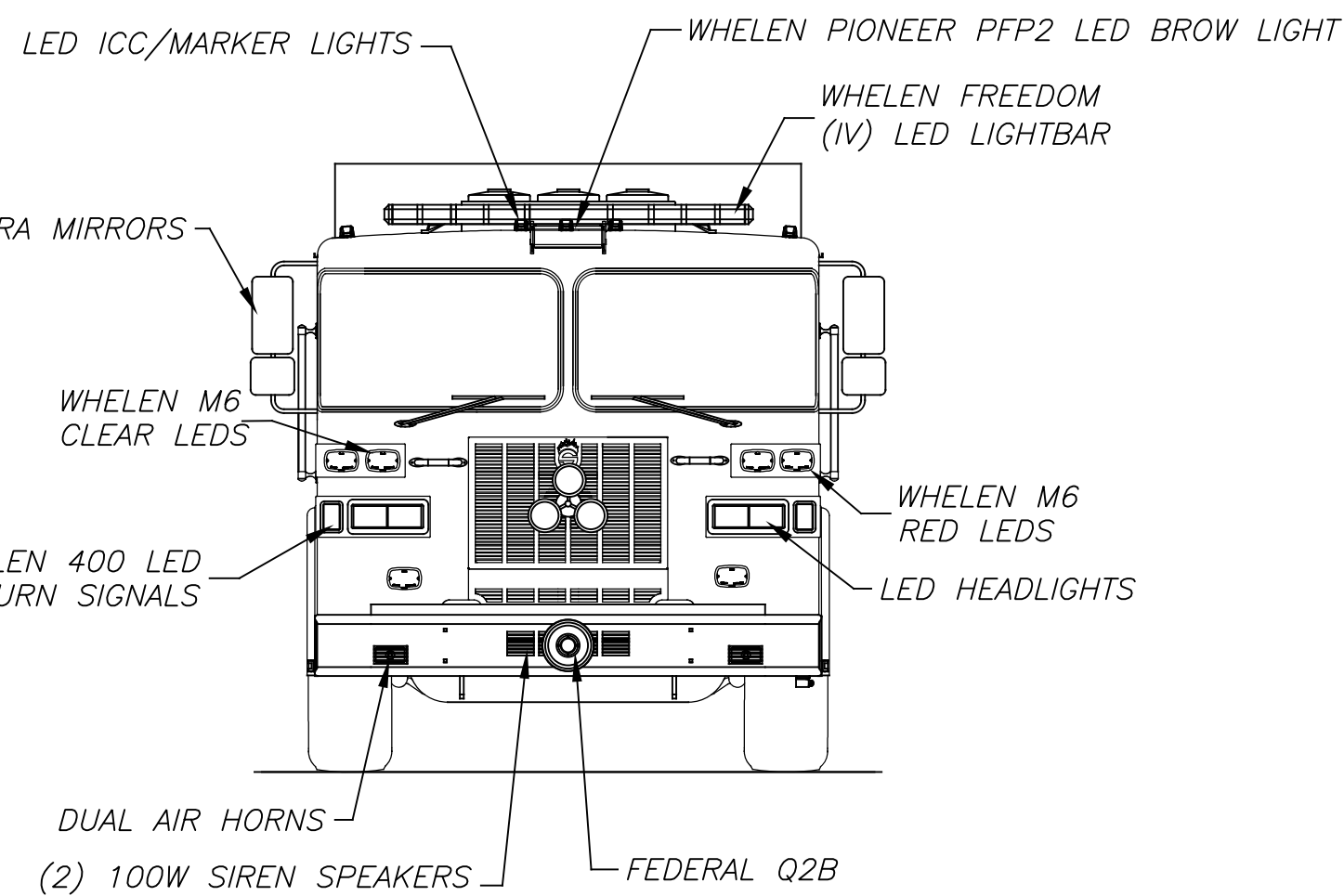
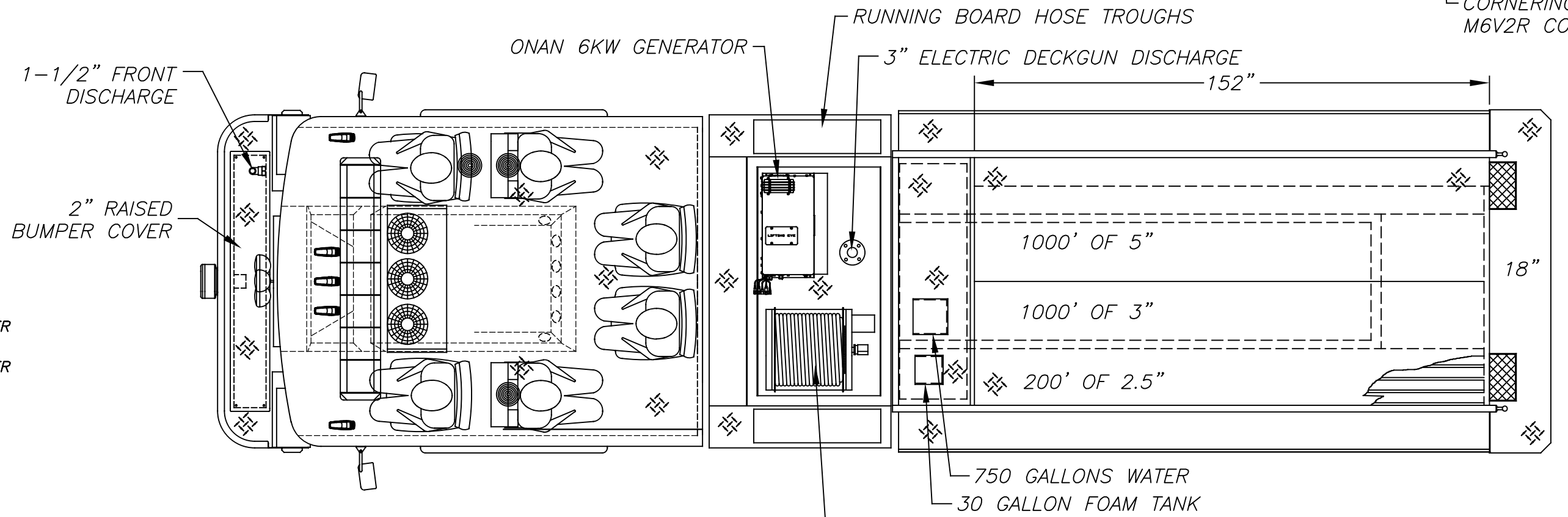

THIS PRINT IS PROVIDED ON A RESTRICTED BASIS AND IS NOT TO BE USED IN ANY WAY DETRIMENTAL TO THE INTEREST OF SUTPHEN CORPORATION.

**SUTPHEN CORPORATION**  
 FIRE APPARATUS SINCE 1890  
 7000 COLUMBUS-MARYSVILLE ROAD  
 AMLIN, OHIO 43002

DR. **M. CLARK**  
 DATE **03/14/17**  
 SCALE **NONE** TDL.

**COWETA COUNTY F.D.**  
 NEWNAN, GA  
 MODIFIED PA-06 56/53

NO. REQ'D.  
 DWG. NO. **HS- 5994**

THE INFORMATION PRESENTED ON THIS DOCUMENT IS TO BE USED FOR ILLUSTRATIVE PURPOSES ONLY AND IT MAY NOT REFLECT, AESTHETICALLY OR OTHERWISE, PAST OR PRESENT MANUFACTURED PRODUCTS. SUTPHEN CORPORATION RESERVES THE RIGHT TO MAKE CHANGES IN THE DESIGN OF OUR PRODUCTS AT ANY TIME, WITHOUT NOTIFICATION.

The undersigned approves this data for construction in accordance with any changes as indicated on these drawings.

APPROVED BY: \_\_\_\_\_ DATE: \_\_\_\_\_  
 (Authorized Fire Dept. Representative)

SALES REPRESENTATIVE: \_\_\_\_\_ DATE: \_\_\_\_\_

REV.	DESCRIPTION	BY	DATE
B	UPDATE COMPONENT LISTING	MJC	08/11/17
A	AFTER PRE-CON	MJC	05/31/17
	PRELIMINARY	MJC	03/14/17