

LADDER CHUTE
 16' COMBI.
 28' 2-SECT.
 16' ROOF
 20' ROOF
 35' 2-SECT.

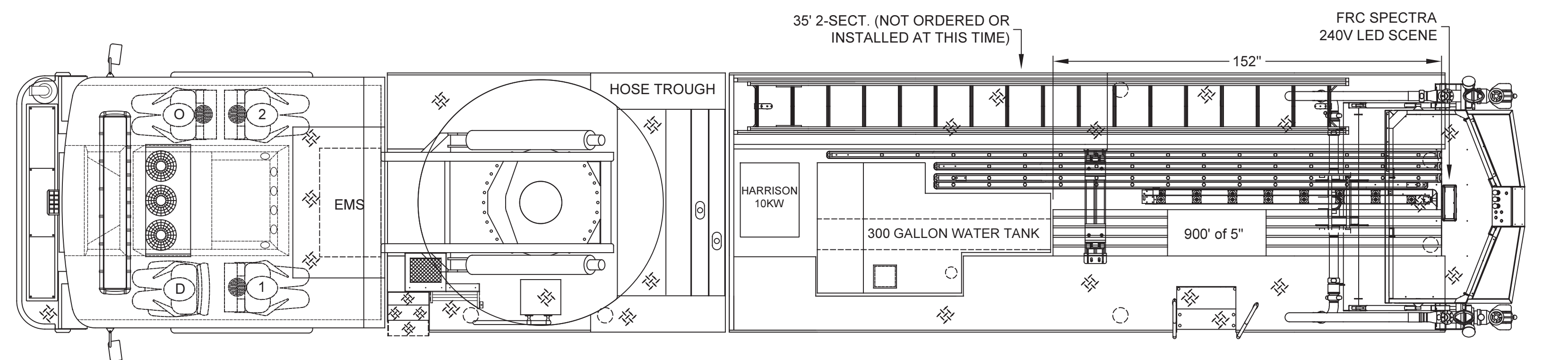

TWO-TONE CAB
 PAINT BREAK OPTION #1
 WHITE OVER RED

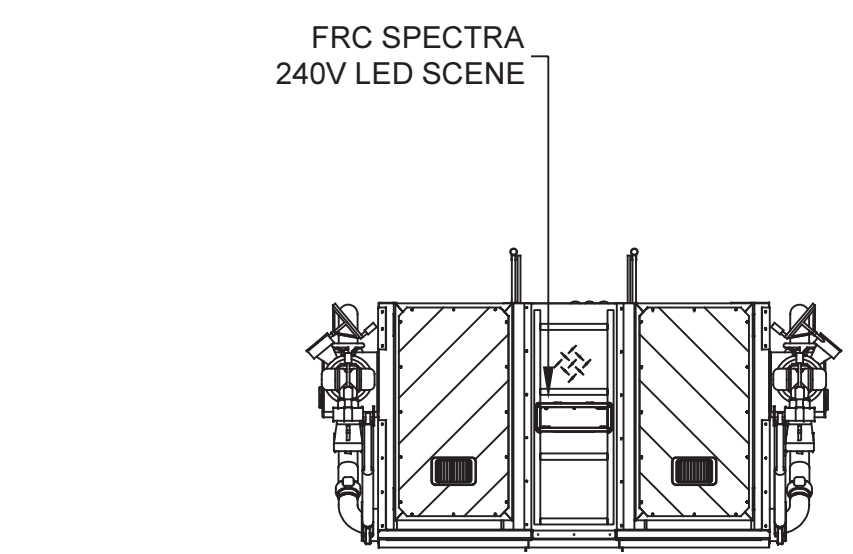
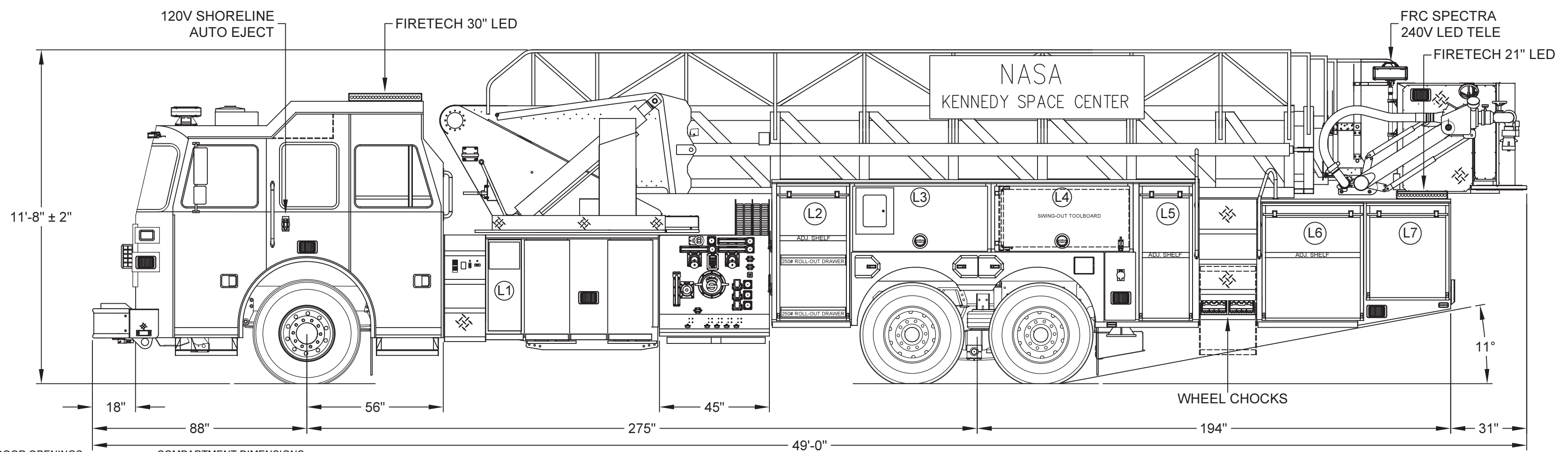
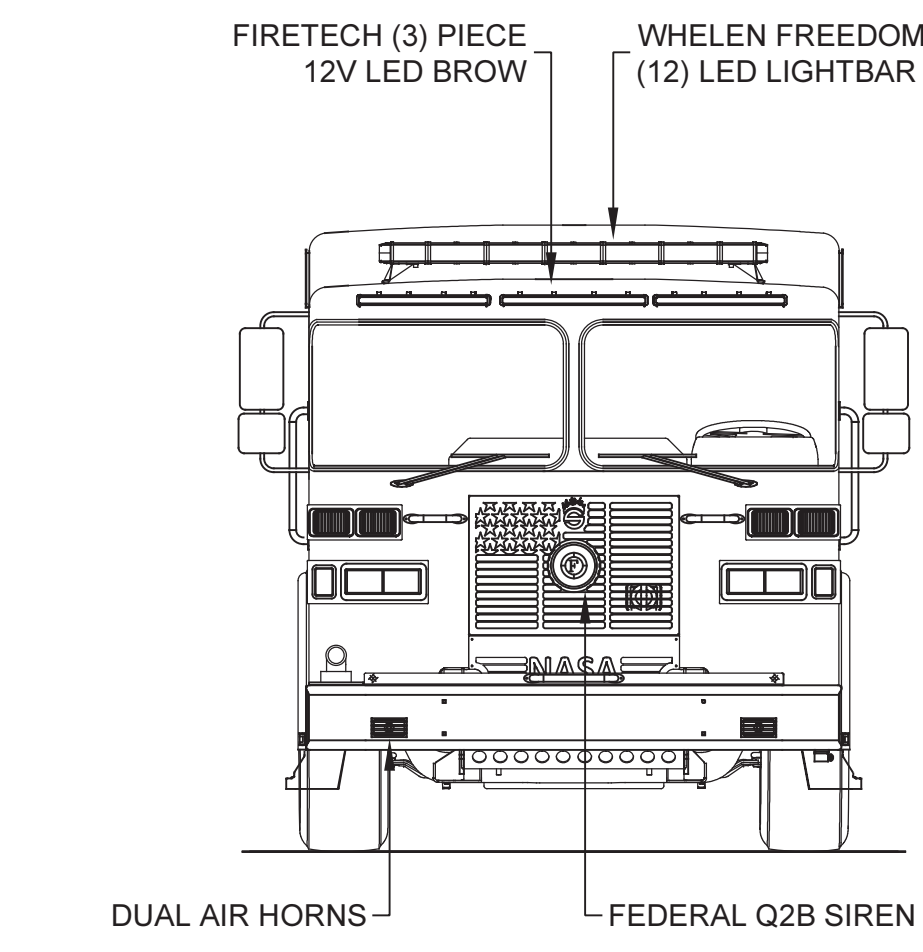

DOOR OPENINGS			COMPARTMENT DIMENSIONS			DOOR OPENINGS			COMPARTMENT DIMENSIONS		
COMPT.	HEIGHT	WIDTH	HEIGHT	WIDTH	DEPTH	COMPT.	HEIGHT	WIDTH	HEIGHT	WIDTH	DEPTH
L1	33 1/4	15 3/8	38 1/2	20 3/8	19 3/4	R1	31	36 3/4	34 3/8	42 1/2	26 1/2
L2	51 3/4	27 1/2	56 1/2	32 1/2	26 1/2	R2	43 3/4	27 1/2	48 1/2	32 1/2	26 1/2
L3	23	57 3/4	27 1/2	62 1/4	12 1/8	R3	15	50 3/4	19 1/2	58	26 1/2
L4	23	57 3/4	27 1/2	62 1/4	26 1/2	R4	15	50 1/4	19 1/2	58	26 1/2
L5	51 3/4	21	56 1/2	26	26 1/2	R5	43 3/4	35 1/2	48 1/2	43 3/4	26 1/2
L6	43 3/4	35	48 1/2	42	26 1/2	R6	43 3/4	35 1/2	48 1/2	43 3/4	26 1/2
L7	35 3/8	30 3/4	40 1/8	34 3/4	26 1/2	R7	35 3/8	30 3/4	40 1/8	34 3/4	26 1/2

TOTAL COMPARTMENT VOLUME- 328.8 CU FT.

DOOR OPENINGS			COMPARTMENT DIMENSIONS		
COMPT.	HEIGHT	WIDTH	HEIGHT	WIDTH	DEPTH
A1	9 1/8	24 1/2	9 7/8	26	88

DIMENSIONS SHOWN ON THIS DRAWING ARE APPROXIMATE AND ARE SUBJECT TO MINOR DEVIATIONS DURING CONSTRUCTION.

IN THE EVENT OF A DISCREPANCY BETWEEN THE SUTPHEN SPECIFICATIONS AND DRAWING, THE SUTPHEN SPECIFICATIONS SHALL PREVAIL.

DRAWING IS FOR REFERENCE ONLY. SOME ITEMS PROPOSED MAY NOT BE SHOWN OR NOTED.

CUSTOMER APPROVAL

NAME: _____

TITLE: _____

DATE: _____

REV.	DESCRIPTION	BY	DATE
F	POST-PRODUCTION SHOP ORDER REVISION TO REFLECT FINAL PRODUCT	RM	10/18/19
E	SEVERAL MINOR CLARIFICATIONS - SEE SO CHANGE SUMMARY ON SHARED	RM	09/27/19
D	BODY STRETCHED IN REAR PER ENGINEERING DESIGN AND CUSTOMER APPROVAL	RM	06/05/19
C	DELETED ERRONEOUS CALL-OUT FOR ROTA-BEAM LIGHT ON FRONT OF CAB	RM	05/29/19

DRAWN BY:	R.MILLER
DATE:	11/28/18
MFG. FACILITY:	DUBLIN

SUTPHEN

NASA
 KENNEDY SPACE CENTER, FL

SPH112 AERIAL PLATFORM

DWG. NO.: HS-6401