

Left Side Compartmentation				
Compt	Doors	Opening Dimensions	Inside Dimensions	Volume
L1	Roll Up	31x56	38x66x27.25	44.8 CU FT
L2	Roll Up	57x22	64x32x27.25	32.3 CU FT
L3	Roll Up	46x56	53x66x27.25	55.2 CU FT
Right Side Compartmentation				
Compt	Doors	Opening Dimensions	Inside Dimensions	Volume
R1	Roll Up	31x56	38x66x27.25/10.25	27.1 CU FT
R2	Roll Up	57x22	64x32x10.25	12.1 CU FT
R3	Roll Up	46x56	53x66x27.25/10.25	33.5 CU FT
Rear Compartmentation				
Compt	Doors	Opening Dimensions	Inside Dimensions	Volume
A1	Roll Up	38x30	42x40x26.25	25.5 CU FT

Waterous 2000gpm Two-Stage
Water Tank Capacity 1000 gal

Total Volume	230.5 CU FT
--------------	-------------

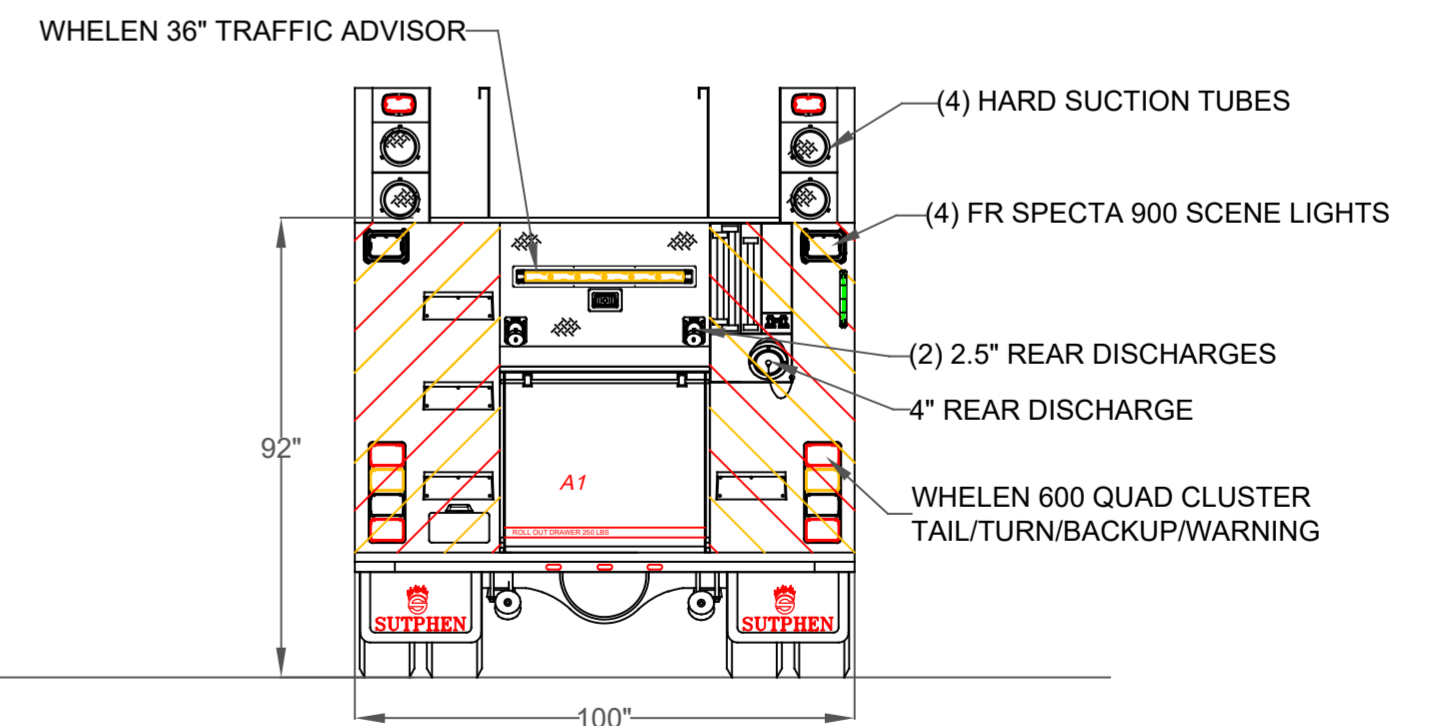
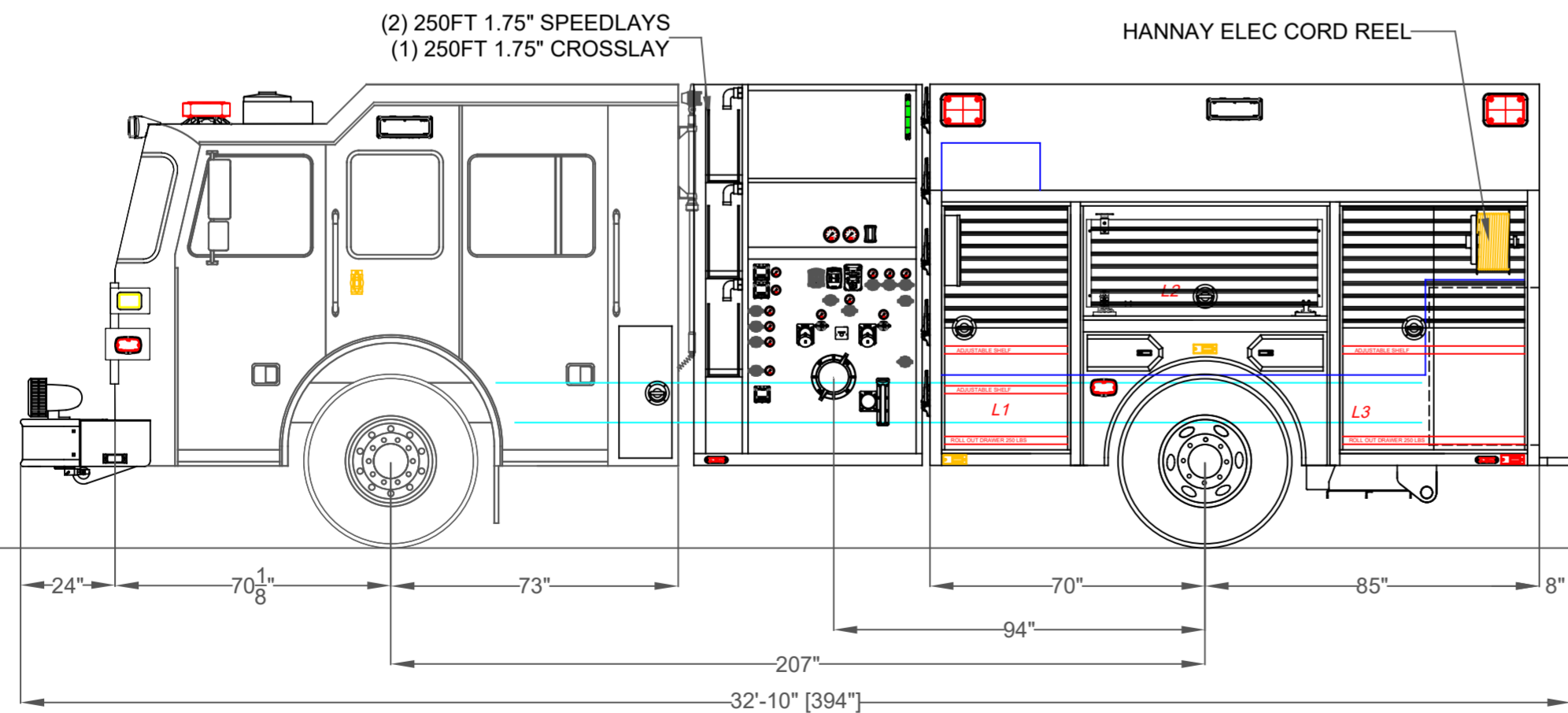

DIMENSIONS SHOWN ON THIS DRAWING ARE APPROXIMATE AND ARE SUBJECT TO MINOR DEVIATIONS DURING CONSTRUCTION.

IN THE EVENT OF A DISCREPANCY BETWEEN THE SUTPHEN SPECIFICATIONS AND DRAWING, THE SUTPHEN SPECIFICATIONS SHALL PREVAIL.

DRAWING IS FOR REFERENCE ONLY. SOME ITEMS PROPOSED MAY NOT BE SHOWN OR NOTED.

CUSTOMER APPROVAL

NAME: _____

TITLE: _____

DATE: _____

REV.	DESCRIPTION	BY	DATE

THIS PRINT IS PROVIDED ON A RESTRICTED BASIS AND IS NOT TO BE USED IN ANY WAY DETRIMENTAL TO THE INTEREST OF SUTPHEN CORPORATION.

DRAWN BY:
J. GORDON

DATE:
08/19/2019

MFG. FACILITY:
SUTPHEN EAST
LAKE ARIEL, PA

SUTPHEN EAST
55 INNOVATION DRIVE
LAKE ARIEL, PA
1-844-776-2889

LOWER ALLOWAYS CREEK FD
HANCOCKS BRIDGE, NJ

CUSTOM ALUMINUM PUMPER

DWG. NO.:
HS 6641