

- HOSEBED**
- 200' OF 1-3/4"
 - 200' OF 1-3/4"
 - 200' OF 2-1/2"
 - 1,000' OF 5"
 - 200' OF 2-1/2"
 - 400' OF 2-1/2"

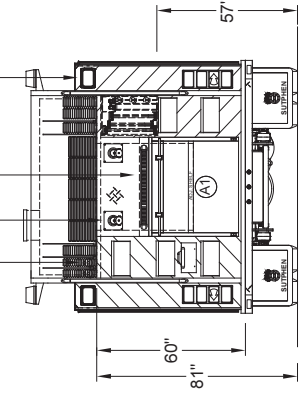

- LADDER CHUTE**
- (1) 24' 2-SECT
 - (1) 14' ROOF
 - (1) BACKBOARD STOR
 - (3) PIKE POLE TUBES
 - (1) 10' FOLDING

COMPT	DOORS	OPENING DIMENSIONS	INSIDE DIMENSIONS	VOLUME
L1	ROLL-UP	35.5" X 55.2"	43.1" X 66" X 27.3"	40.8 CU.FT.
L2	ROLL-UP	55.5" X 19.0"	61.6" X 28.8" X 27.3"	28.0 CU.FT.
L3	ROLL-UP	48.5" X 55.2"	53.4" X 66" X 27.3"	50.5 CU.FT.

- RIGHT SIDE COMPARTMENTS**
- (1) 24' 2-SECT
 - (1) 14' ROOF
 - (1) BACKBOARD STOR
 - (3) PIKE POLE TUBES
 - (1) 10' FOLDING

COMPT	DOORS	OPENING DIMENSIONS	INSIDE DIMENSIONS	VOLUME
R1	ROLL-UP	35.5" X 55.2"	43.1" X 66" X 27.3"	31.1 CU.FT.
R2	ROLL-UP	55.5" X 19.0"	61.6" X 28.8" X 10.5"	10.8 CU.FT.
R3	ROLL-UP	48.5" X 55.2"	53.4" X 66" X 27.3"	38.6 CU.FT.

- REAR STEP COMPARTMENT**
- (1) 24' 2-SECT
 - (1) 14' ROOF
 - (1) BACKBOARD STOR
 - (3) PIKE POLE TUBES
 - (1) 10' FOLDING

COMPT	DOORS	OPENING DIMENSIONS	INSIDE DIMENSIONS	VOLUME
A1	ROLL-UP	37.5" X 30.8"	40" X 40" X 31"	28.7 CU.FT.
TOTAL:				228.5 CU.FT.

CUSTOMER APPROVAL

NAME: _____ TITLE: _____ DATE: _____

DIMENSIONS SHOWN ON THIS DRAWING ARE APPROXIMATE AND ARE SUBJECT TO MINOR DEVIATIONS DURING CONSTRUCTION. IN THE EVENT OF A DISCREPANCY BETWEEN THE SUTPHEN SPECIFICATIONS AND DRAWING, THE SUTPHEN SPECIFICATIONS SHALL PREVAIL. DRAWING IS FOR REFERENCE ONLY. SOME ITEMS PROPOSED MAY NOT BE SHOWN OR NOTED.

SHIP CREW CAB HANDRAILS LOOSE TO BE PLACED AT FINAL. HIGH IDLE SWITCH DELETED
250# DRAWER IN L1 WILL BE NON-ADJUSTABLE IN ORDER TO INCREASE USABLE WIDTH
REVA SHOP ORDER

DESCRIPTION

THIS PRINT IS PROVIDED ON A RESTRICTED BASIS AND IS NOT TO BE USED IN ANY WAY DETRIMENTAL TO THE INTEREST OF SUTPHEN CORPORATION.

DRAWN BY: R. MILLER
DATE: 05/13/18
MFG FACILITY: DUBLIN

DATE: 01/08/19
DATE: 09/28/18
DATE: 06/14/18

REV: _____

BY: _____

HS-6281

SUTPHEN
KISSIMMEE FIRE DEPARTMENT
KISSIMMEE, FL
CUSTOM PUMPER - S2 BODY