

**HOSEBED**  
1,400' OF 4"  
500' OF 2.5"  
300' OF 2.5"  
(2) 10' HARD SUCT.

**LADDER CHUTE**  
(1) 24' 2-SECT.  
(1) 14' ROOF  
(1) 10' FOLDING  
(1) BBOARD STOR  
(2) NY ROOF HOOK STOR

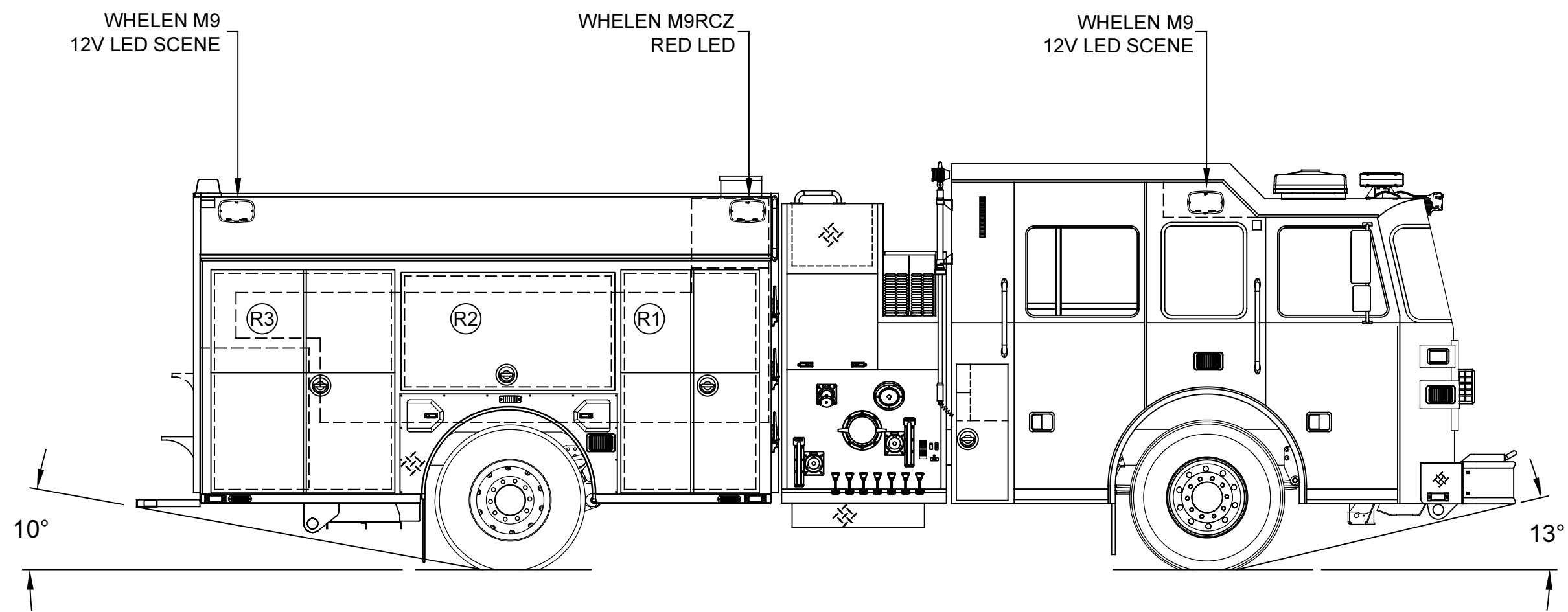

LEFT SIDE COMPARTMENTS				
COMPT	DOORS	OPENING DIMENSIONS	INSIDE DIMENSIONS	VOLUME
L1	DOUBLE	35.5" w X 58.4" h	43.1" w X 66" h X 27.3" d	40.8 CU. FT. (10" h X 10.5" d UPPER)
L2	LIFT-UP	55.0" w X 31.9" h	61.6" w X 36.8" h X 10.5" d	29.8 CU. FT. (10" h X 10.5" d UPPER)
L3	DOUBLE	48.5" w X 58.4" h	53.4" w X 66" h X 27.3" d	49.6 CU. FT. (10" h X 10.5" d UPPER)

  

RIGHT SIDE COMPARTMENTS				
COMPT	DOORS	OPENING DIMENSIONS	INSIDE DIMENSIONS	VOLUME
R1	DOUBLE	35.5" w X 58.4" h	43.1" w X 66" h X 27.3" d	31.1 CU. FT. (33" h X 10.5" d UPPER)
R2	LIFT-UP	55.0" w X 31.9" h	61.6" w X 36.8" h X 10.5" d	13.8 CU. FT. (33" h X 10.5" d UPPER)
R3	DOUBLE	48.5" w X 58.4" h	53.4" w X 66" h X 27.3" d	37.8 CU. FT. (33" h X 10.5" d UPPER)

  

REAR STEP COMPARTMENT				
COMPT	DOORS	OPENING DIMENSIONS	INSIDE DIMENSIONS	VOLUME
A1	ROLL-UP	37.5" w X 32.8" h	40" w X 40" h X 31" d	28.7 CU. FT.

**TOTAL: 231.6 CU.FT.**

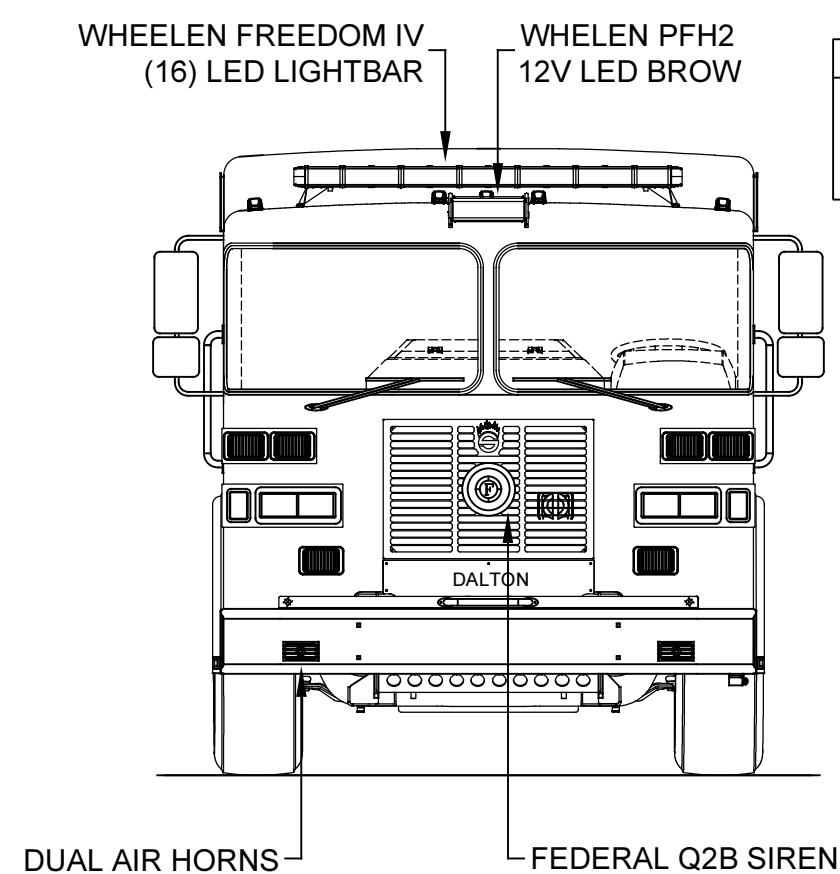
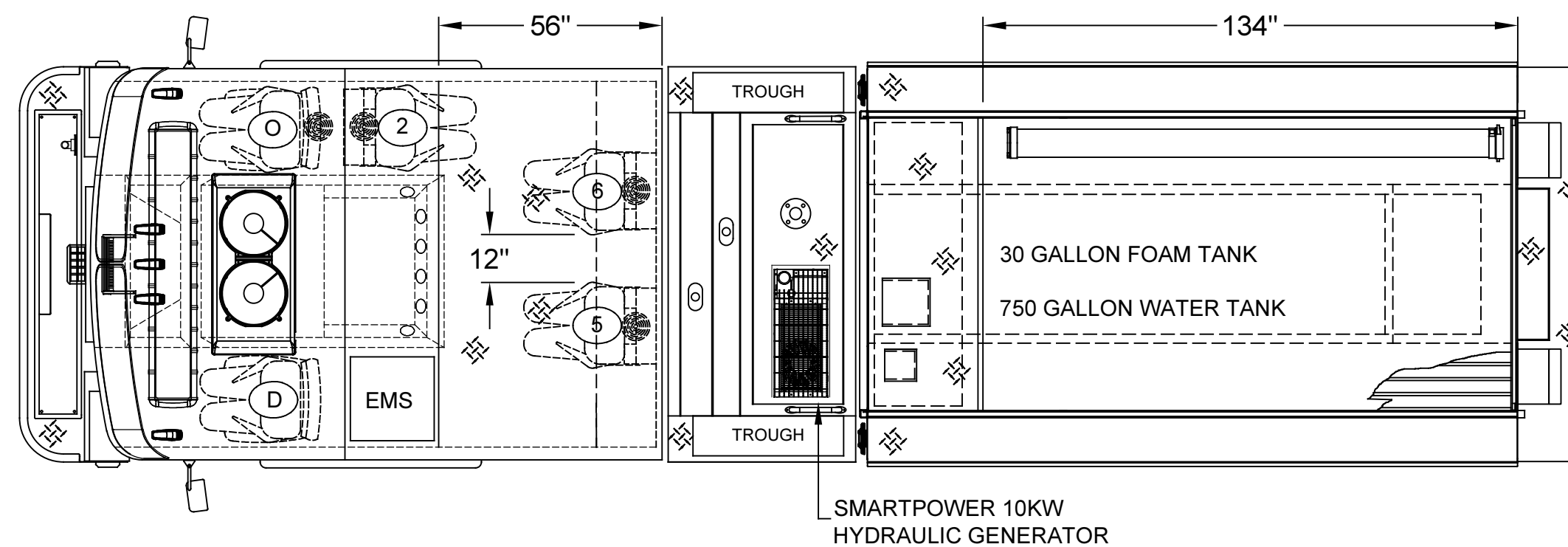

**TWO-TONE CAB & BODY**  
-BLACK OVER RED  
-PAINT BREAK #1 FOR CAB  
-TOP OF BODY COMPTS FOR BODY

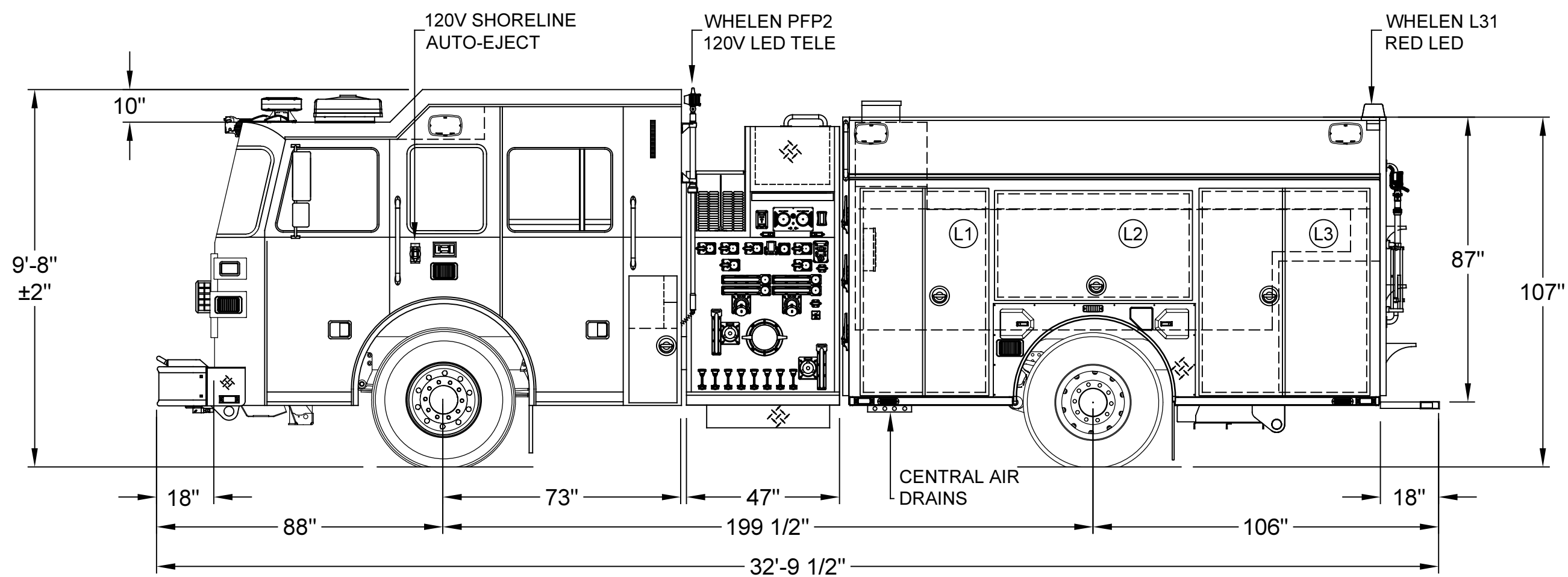

DIMENSIONS SHOWN ON THIS DRAWING ARE APPROXIMATE AND ARE SUBJECT TO MINOR DEVIATIONS DURING CONSTRUCTION.

**CUSTOMER APPROVAL**

NAME: \_\_\_\_\_  
TITLE: \_\_\_\_\_  
DATE: \_\_\_\_\_

E	DEALER SUPPLIED INTERCOM CHANGED FROM DAVID CLARK TO SETCOM	TF	09/27/2021
D	CHANGED FROM REMOVABLE BAR TO FIXED DIVIDER FOR HOSE BED	TF	07/09/2021
C	REFERENCE SHOP ORDER CHANGE DOCUMENT ON SHARED DRIVE	TF	07/07/2021
B	REFERENCE SHOP ORDER CHANGE DOCUMENT ON SHARED DRIVE	TF	07/01/2021
REV.	DESCRIPTION	BY	DATE

DRAWN BY:  
T.FAHOUM  
DATE:  
01/06/21  
MFG. FACILITY:  
DUBLIN



CITY OF DALTON FIRE DEPARTMENT  
DALTON, GA

CUSTOM PUMPER - PA-12 BODY

DWG. NO.: HS-7000

THIS PRINT IS PROVIDED ON A RESTRICTED BASIS AND IS NOT TO BE USED IN ANY WAY DETRIMENTAL TO THE INTEREST OF SUTPHEN CORPORATION.