

Left Side Compartmentation				
Compt	Doors	Opening Dimensions	Inside Dimensions	Volume
L1	HINGE	53x55	60x65x24.25/10.25	38.7 CU FT
L2	HINGE	53x23	60x32x10.25	12.1 CU FT
L3	HINGE	43x55	50x65x24.25/10.25	34.1 CU FT

Right Side Compartmentation				
Compt	Doors	Opening Dimensions	Inside Dimensions	Volume
R1	HINGE	53x55	60x65x24.25/10.25	38.7 CU FT
R2	HINGE	53x23	60x32x10.25	12.1 CU FT
R3	HINGE	43x55	50x65x24.25/10.25	34.1 CU FT

Hale Qmax-XS 1500 single stage
 Water Tank Capacity 2000 gal
 Foam Tank Capacity 20 gal

Total Volume	134.3 CU Ft
--------------	-------------

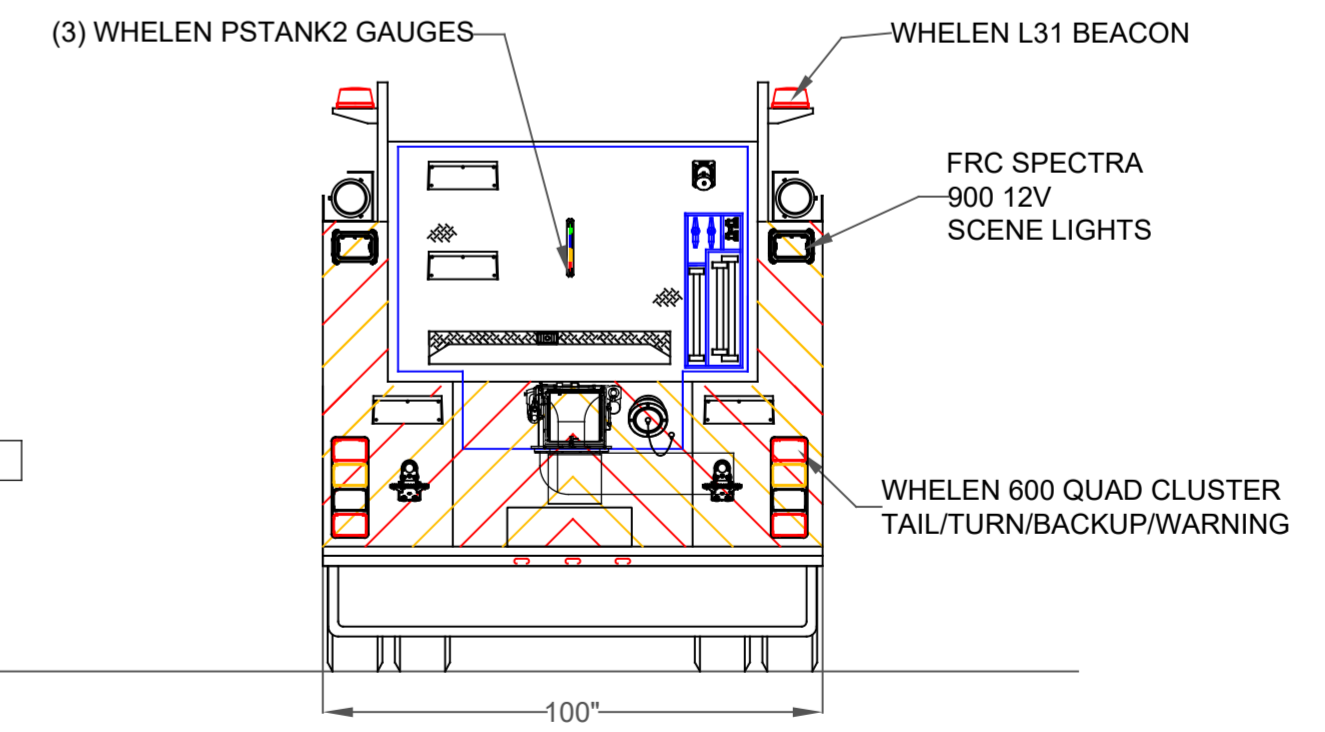
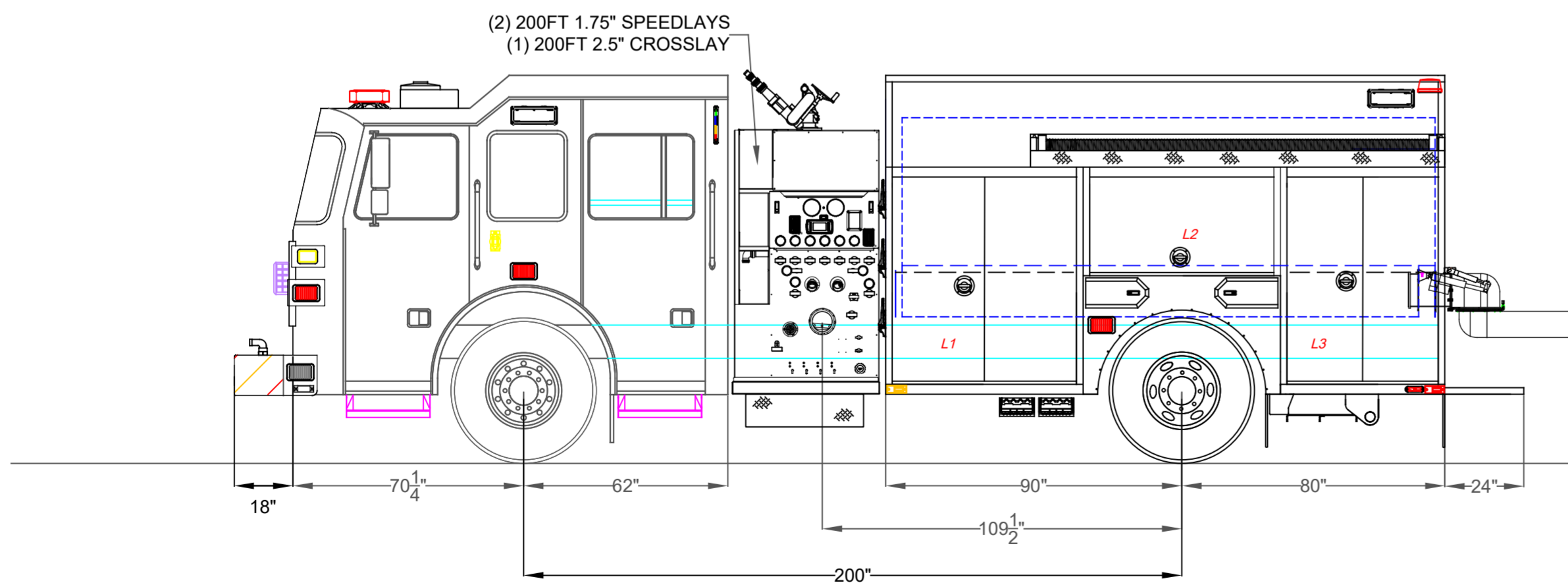

DIMENSIONS SHOWN ON THIS DRAWING ARE APPROXIMATE AND ARE SUBJECT TO MINOR DEVIATIONS DURING CONSTRUCTION.

IN THE EVENT OF A DISCREPANCY BETWEEN THE SUTPHEN SPECIFICATIONS AND DRAWING, THE SUTPHEN SPECIFICATIONS SHALL PREVAIL.

DRAWING IS FOR REFERENCE ONLY. SOME ITEMS PROPOSED MAY NOT BE SHOWN OR NOTED.

CUSTOMER APPROVAL

NAME: _____

TITLE: _____

DATE: _____

REV.	DESCRIPTION	BY	DATE

THIS PRINT IS PROVIDED ON A RESTRICTED BASIS AND IS NOT TO BE USED IN ANY WAY DETRIMENTAL TO THE INTEREST OF SUTPHEN CORPORATION.

DRAWN BY: J. GORDON

DATE: 11/02/20

MFG. FACILITY: SUTPHEN EAST LAKE ARIEL, PA

DWG. NO.: HS 6946

SUTPHEN EAST
 55 INNOVATION DRIVE
 LAKE ARIEL, PA
 1-844-776-2889

MARION TOWNSHIP FD
 MARION TWP, OH

CUSTOM STAINLESS DRYSIDE TANKER