

Left Side Compartmentation				
Compt	Doors	Opening Dimensions	Inside Dimensions	Volume
WxHxD				
L1	Roll Up	43x62	50x72x24.25/10.25	35.1 CU FT
L2	Roll Up	50x28	57.25x38x10.25	12.9 CU FT
L3	Roll Up	50x28	57.25x38x10.25	12.9 CU FT
L4	Roll Up	35x62	42x72x24.25/10.25	29.5 CU FT
Right Side Compartmentation				
Compt	Doors	Opening Dimensions	Inside Dimensions	Volume
R1	Roll Up	43x23	50x33x24.25	23.2 CU FT
R2	Roll Up	35x23	42x33x24.25	19.5 CU FT

Hale Qmax 1500 single stage  
Water Tank Capacity 3000 gal

Total Volume	133.0 CU FT
--------------	-------------

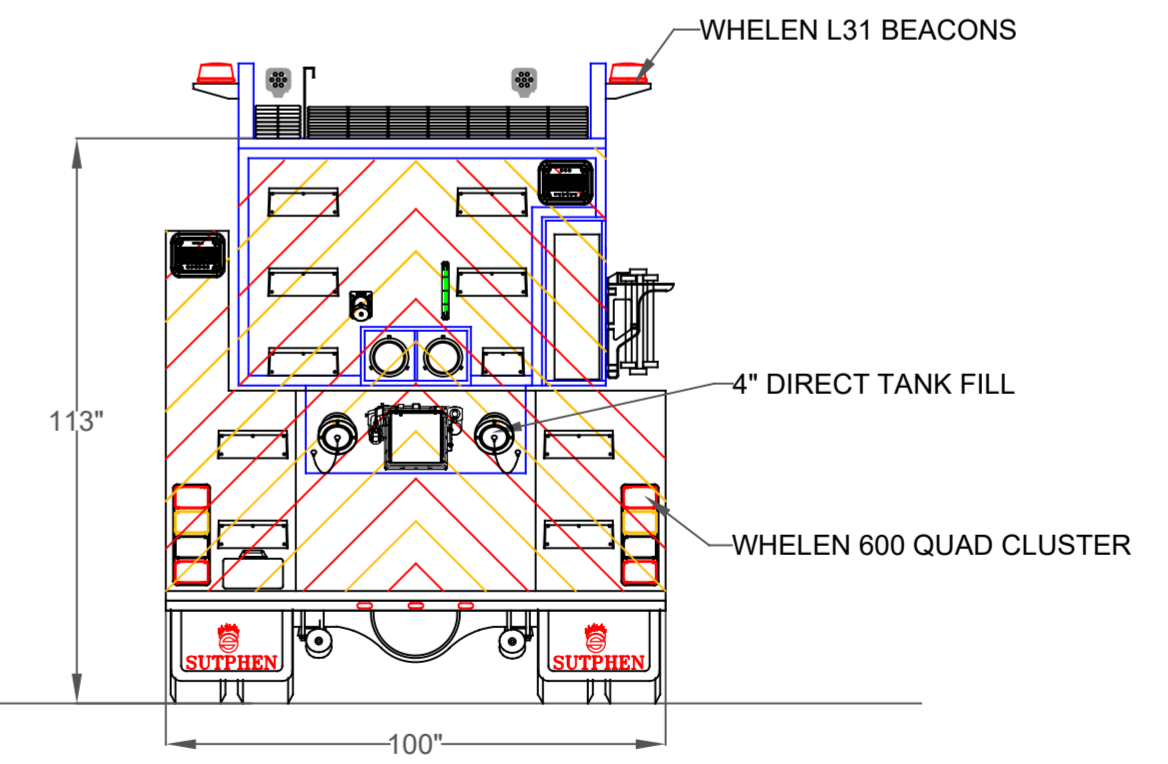
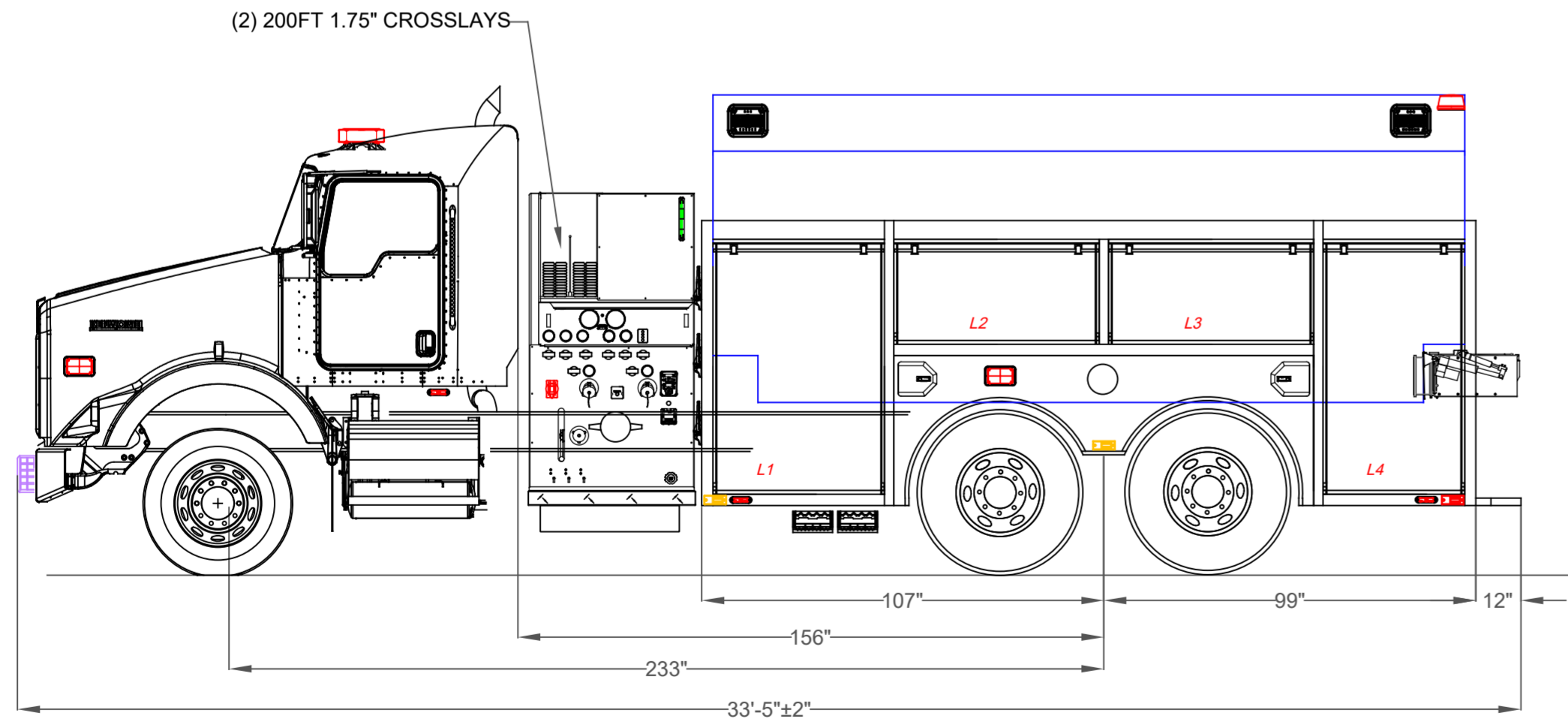

DIMENSIONS SHOWN ON THIS DRAWING ARE APPROXIMATE AND ARE SUBJECT TO MINOR DEVIATIONS DURING CONSTRUCTION.  IN THE EVENT OF A DISCREPANCY BETWEEN THE SUTPHEN SPECIFICATIONS AND DRAWING, THE SUTPHEN SPECIFICATIONS SHALL PREVAIL.  DRAWING IS FOR REFERENCE ONLY. SOME ITEMS PROPOSED MAY NOT BE SHOWN OR NOTED.	CUSTOMER APPROVAL NAME: _____ TITLE: _____ DATE: _____		REV. _____ DESCRIPTION _____ BY _____ DATE _____	DRAWN BY: J. GORDON  DATE: 08/11/2020  MFG. FACILITY: SUTPHEN EAST LAKE ARIEL, PA	SUTPHEN EAST 55 INNOVATION DRIVE LAKE ARIEL, PA 1-844-776-2889  BOWERSTON VOLUNTEER FIRE DEPT. BOWERSTON, OH  COMMERCIAL WETSIDETANKER  DWG. NO.: HS 6891
	THIS PRINT IS PROVIDED ON A RESTRICTED BASIS AND IS NOT TO BE USED IN ANY WAY DETRIMENTAL TO THE INTEREST OF SUTPHEN CORPORATION.				