

Left Side Compartmentation				
Compt	Doors	Opening Dimensions	Inside Dimensions	Volume
			WxHxD	
L1	Roll Up	49x56	56x66x24.25/10.25	39.2 CU FT
L2	Roll Up	57x22	64x28x10.25	10.6 CU FT
L3	Roll Up	46x56	53x66x24.25/10.25	37.1 CU FT
Right Side Compartmentation				
Compt	Doors	Opening Dimensions	Inside Dimensions	Volume
R1	Roll Up	49x56	56x66x24.25/10.25	39.2 CU FT
R2	Roll Up	46x56	64x28x10.25	10.6 CU FT
R3	Roll Up	46x56	53x66x24.25/10.25	37.1 CU FT

Hale Qmax-xs 2000 single stage  
 Water Tank Capacity 2000 gal  
 Foam Tank Capacity 30 gal

Total Volume	173.8 CU FT
--------------	-------------

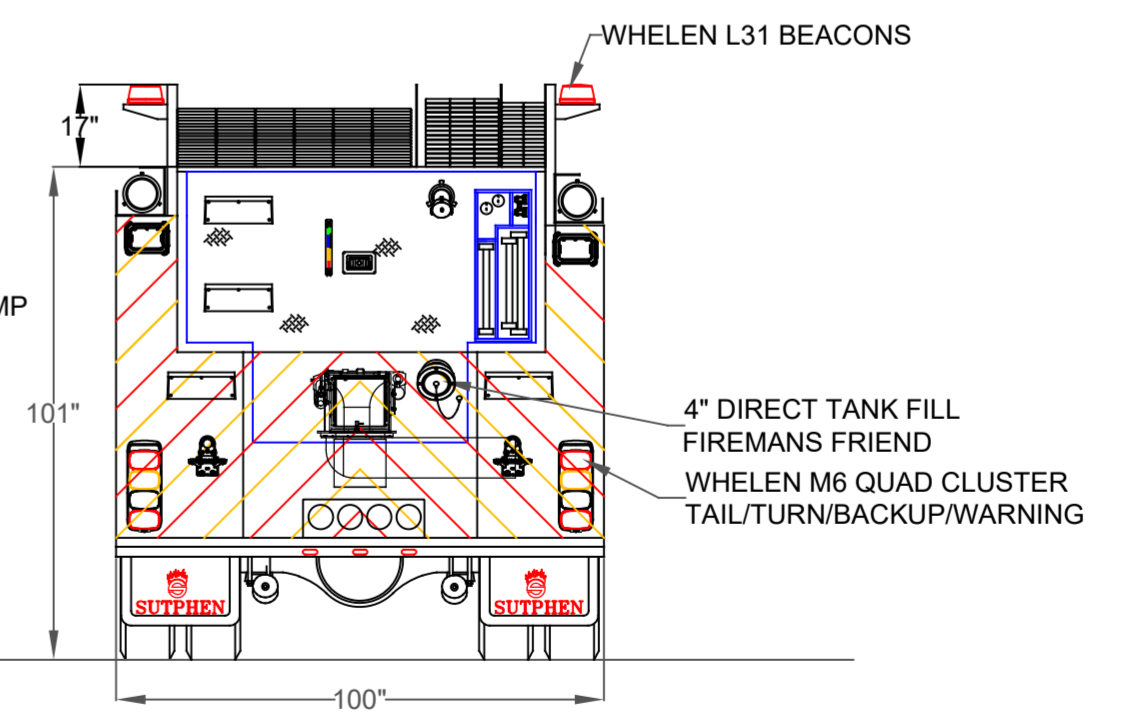
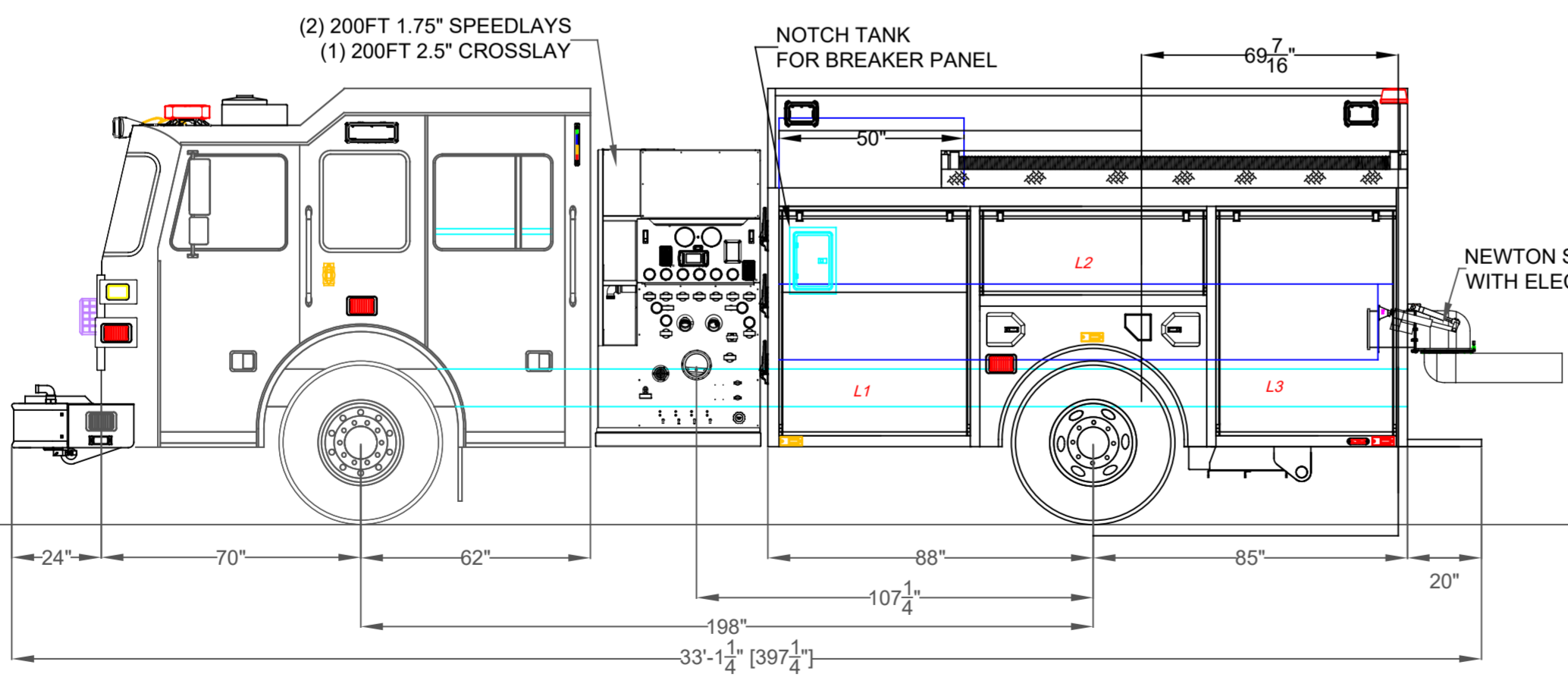

DIMENSIONS SHOWN ON THIS DRAWING ARE APPROXIMATE AND ARE SUBJECT TO MINOR DEVIATIONS DURING CONSTRUCTION.	CUSTOMER APPROVAL				DRAWN BY: S.DORFMAN		SUTPHEN EAST 55 INNOVATION DRIVE LAKE ARIEL, PA 1-844-776-2889	
	NAME:		B	DELETE 1 SCBA FROM REAR COMPARTMENT STORAGE	SED	8/24/20	DATE: 11/8/19	NORTHERN UNION JOINT FIRE DISTRICT RICHWOOD, OH
IN THE EVENT OF A DISCREPANCY BETWEEN THE SUTPHEN SPECIFICATIONS AND DRAWING, THE SUTPHEN SPECIFICATIONS SHALL PREVAIL.	TITLE:		A	CHANGES FROM PRE-CON	SED	11/8/19	MFG. FACILITY: SUTPHEN EAST LAKE ARIEL, PA	CUSTOM ALUMINUM DRYSIDE TANKER
DRAWING IS FOR REFERENCE ONLY. SOME ITEMS PROPOSED MAY NOT BE SHOWN OR NOTED.	DATE:		REV.	DESCRIPTION	BY	DATE	DWG. NO.:	HS 6637 PRODUCTION DRAWING
THIS PRINT IS PROVIDED ON A RESTRICTED BASIS AND IS NOT TO BE USED IN ANY WAY DETRIMENTAL TO THE INTEREST OF SUTPHEN CORPORATION.								