

LEFT SIDE COMPARTMENTATION				
COMPT	DOORS	INSIDE DIMENSIONS	DOOR OPENING DIMENSIONS	VOLUME
L1		40"W X 66"H X 26"D		37.4 CU. FT.
L2		59"W X 31 1/2"H X 26"D		28.4 CU. FT.
L3		51 1/2"W X 66"H X 26"D		47.4 CU. FT.

RIGHT SIDE COMPARTMENTATION				
COMPT	DOORS	INSIDE DIMENSIONS	DOOR OPENING DIMENSIONS	VOLUME
R1		40"W X 66"H X 26"D		37.4 CU. FT.
R2		59"W X 31 1/2"H X 26"D		28.4 CU. FT.
R3		51 1/2"W X 66"H X 26"D		47.4 CU. FT.

REAR STEP COMPARTMENT				
COMPT	DOORS	INSIDE DIMENSIONS	DOOR OPENING DIMENSIONS	VOLUME
A1	ROLL-UP	39 1/2"W X 28"H X 31"D	36 3/4"W X 19"H	19.8 CU. FT.

BASE STORAGE: 246 CU. FT.

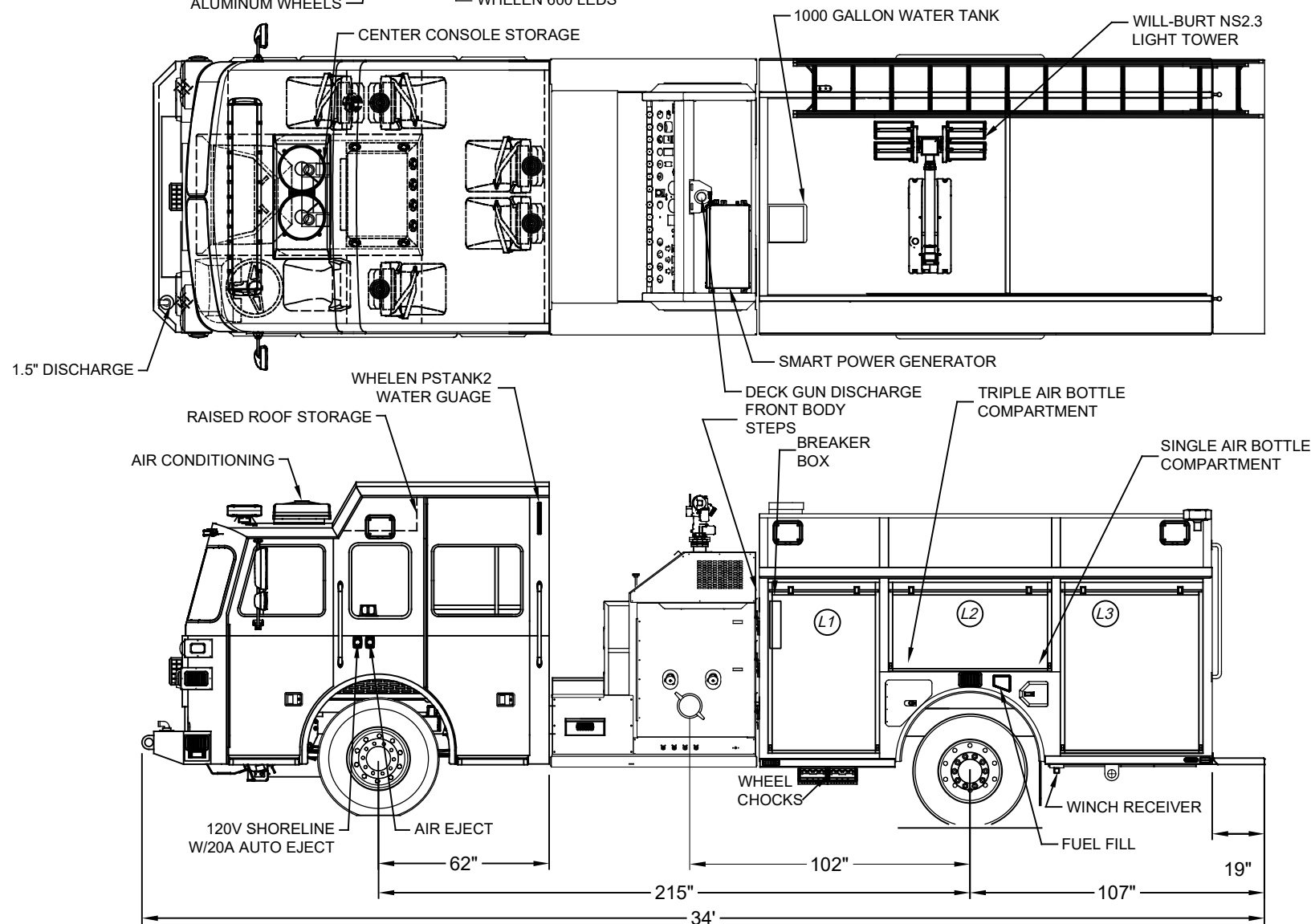
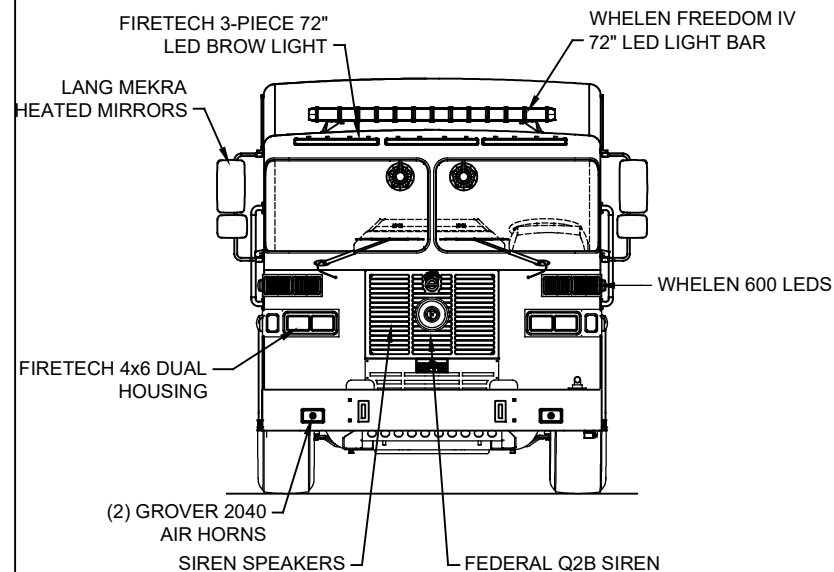

DIMENSIONS SHOWN ON THIS DRAWING ARE APPROXIMATE AND ARE SUBJECT TO MINOR DEVIATIONS DURING CONSTRUCTION.

IN THE EVENT OF A DISCREPANCY BETWEEN THE SUTPHEN SPECIFICATIONS AND DRAWING, THE SUTPHEN SPECIFICATIONS SHALL PREVAIL.

DRAWING IS FOR REFERENCE ONLY. SOME ITEMS PROPOSED MAY NOT BE SHOWN OR NOTED.

CUSTOMER APPROVAL

NAME: _____

TITLE: _____

DATE: _____

REV.	DESCRIPTION	BY	DATE
B	REVISED TO MATCH REV E OF SHOP ORDER	AA	7/15/2020
A	REVISED TO MATCH REV A OF SHOP ORDER	JNH	2/3/2020

THIS PRINT IS PROVIDED ON A RESTRICTED BASIS AND IS NOT TO BE USED IN ANY WAY DETRIMENTAL TO THE INTEREST OF SUTPHEN CORPORATION.

DRAWN BY: VPH
 DATE: 10/25/2019
 MFG. FACILITY: SPRINGFIELD
 DWG. NO.: HS-6608

SUTPHEN
 RICHLAND TOWNSHIP
 GIBSONIA, PA
 CUSTOM PUMPER -PRG 1