

Left Side Compartmentation				
Compt	Doors	Opening Dimensions	Inside Dimensions	Volume
L1	Roll Up	29x26	WxHxD	15.2 CU FT
Right Side Compartmentation				
Compt	Doors	Opening Dimensions	Inside Dimensions	Volume
R1	Roll Up	55x26	62x36x24.25	31.3 CU FT
R2	Roll Up	29x26	36x36x24.25	15.2 CU FT

Hale DSD 1000GPM PTO
 Water Tank Capacity 3500 gal
 Foam Tank Capacity 50 gal

Total Volume	61.6 CU Ft
--------------	------------

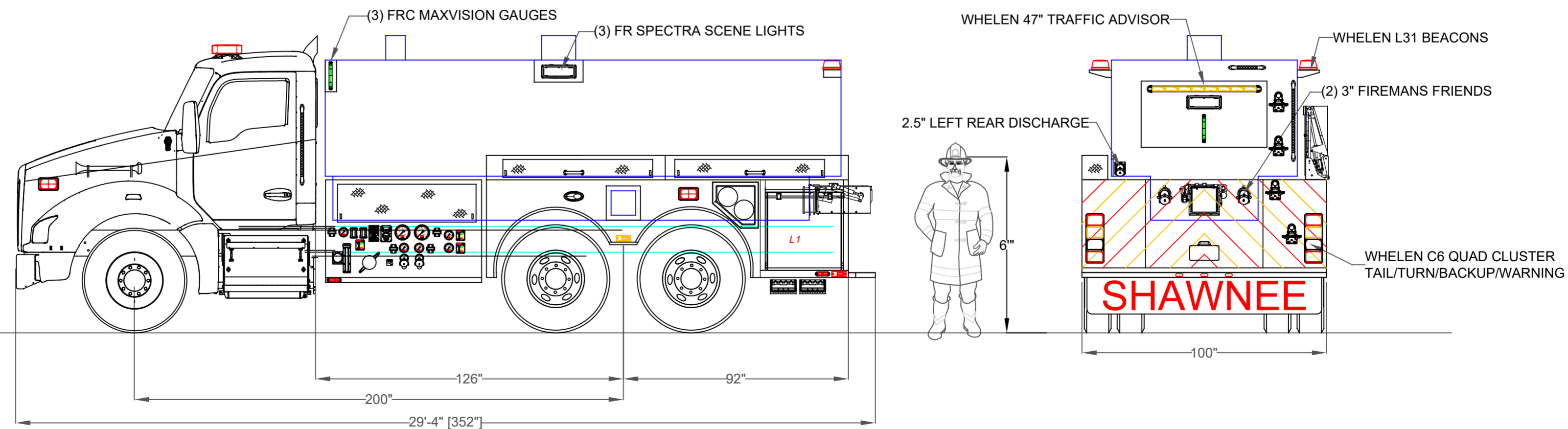
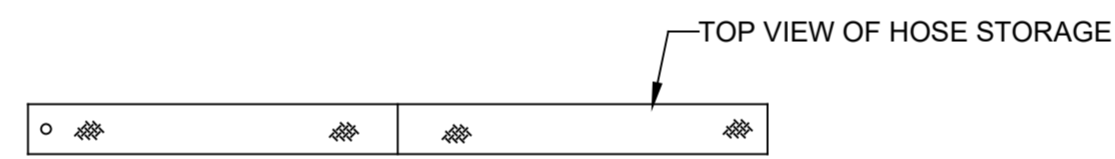

DIMENSIONS SHOWN ON THIS DRAWING ARE APPROXIMATE AND ARE SUBJECT TO MINOR DEVIATIONS DURING CONSTRUCTION.

IN THE EVENT OF A DISCREPANCY BETWEEN THE SUTPHEN SPECIFICATIONS AND DRAWING, THE SUTPHEN SPECIFICATIONS SHALL PREVAIL.

DRAWING IS FOR REFERENCE ONLY. SOME ITEMS PROPOSED MAY NOT BE SHOWN OR NOTED.

CUSTOMER APPROVAL

NAME: _____

TITLE: _____

DATE: _____

REV.	DESCRIPTION	BY	DATE

THIS PRINT IS PROVIDED ON A RESTRICTED BASIS AND IS NOT TO BE USED IN ANY WAY DETRIMENTAL TO THE INTEREST OF SUTPHEN CORPORATION.

DRAWN BY: J. GORDON

DATE: 03/14/2019

MFG. FACILITY: SUTPHEN EAST LAKE ARIEL, PA

DWG. NO.: SALES DRAWING

SUTPHEN EAST
 55 INNOVATION DRIVE
 LAKE ARIEL, PA
 1-844-776-2889

SHAWNEE FIRE COMPANY
 SHAWNEE-ON-DELAWARE, PA

COMMERCIAL WETSIDE TANKER