

Hose Load
 1:400ft of 3" Pre-Connected
 2:1200ft of 5"
 3:400ft of 2.5"
 4:400ft of 1.75" Pre-Connected

Left Side Compartmentation				
Compt	Doors	Opening Dimensions	Inside Dimensions	Volume
WxHxD				
L1	Roll Up	49x56	56x66x27.25	58.3 CU FT
L2	Roll Up	57x22	64x32x27.25	32.3 CU FT
L3	Roll Up	46x56	53x66x27.25	55.2 CU FT
Right Side Compartmentation				
Compt	Doors	Opening Dimensions	Inside Dimensions	Volume
WxHxD				
R1	Roll Up	49x56	56x66x27.25	58.3 CU FT
R2	Roll Up	57x22	64x32x27.25	32.3 CU FT
R3	Roll Up	46x56	53x66x27.25	55.2 CU FT
Rear Compartmentation				
Compt	Doors	Opening Dimensions	Inside Dimensions	Volume
WxHxD				
A1	Roll Up	23x30	30x40x26.25	18.2 CU FT
				Total Volume
				309.8 CU FT

Hale Qmax 1500 single stage
Water Tank Capacity 1000 gal
Foam Tank Capacity 30 gal

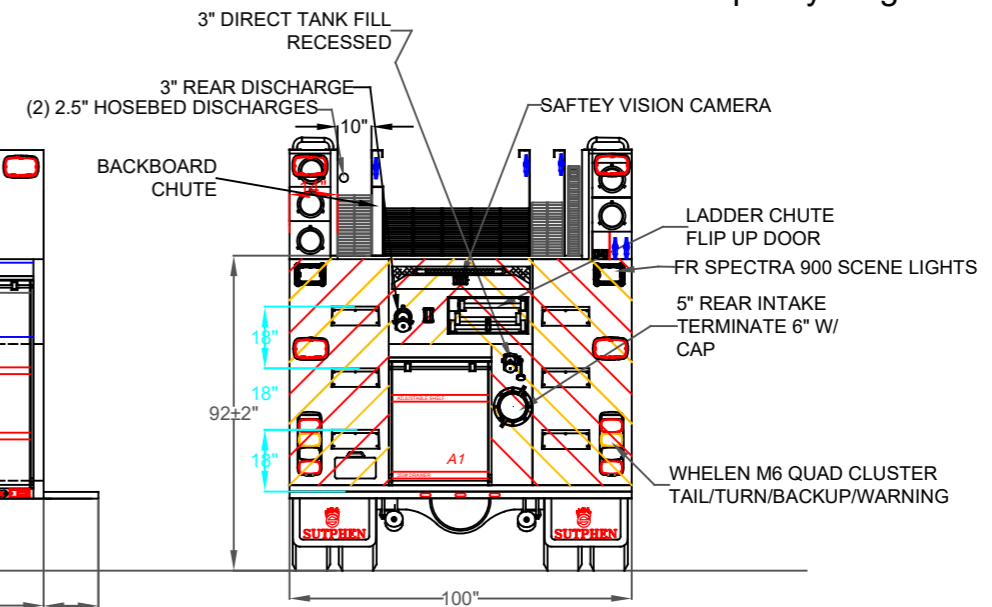
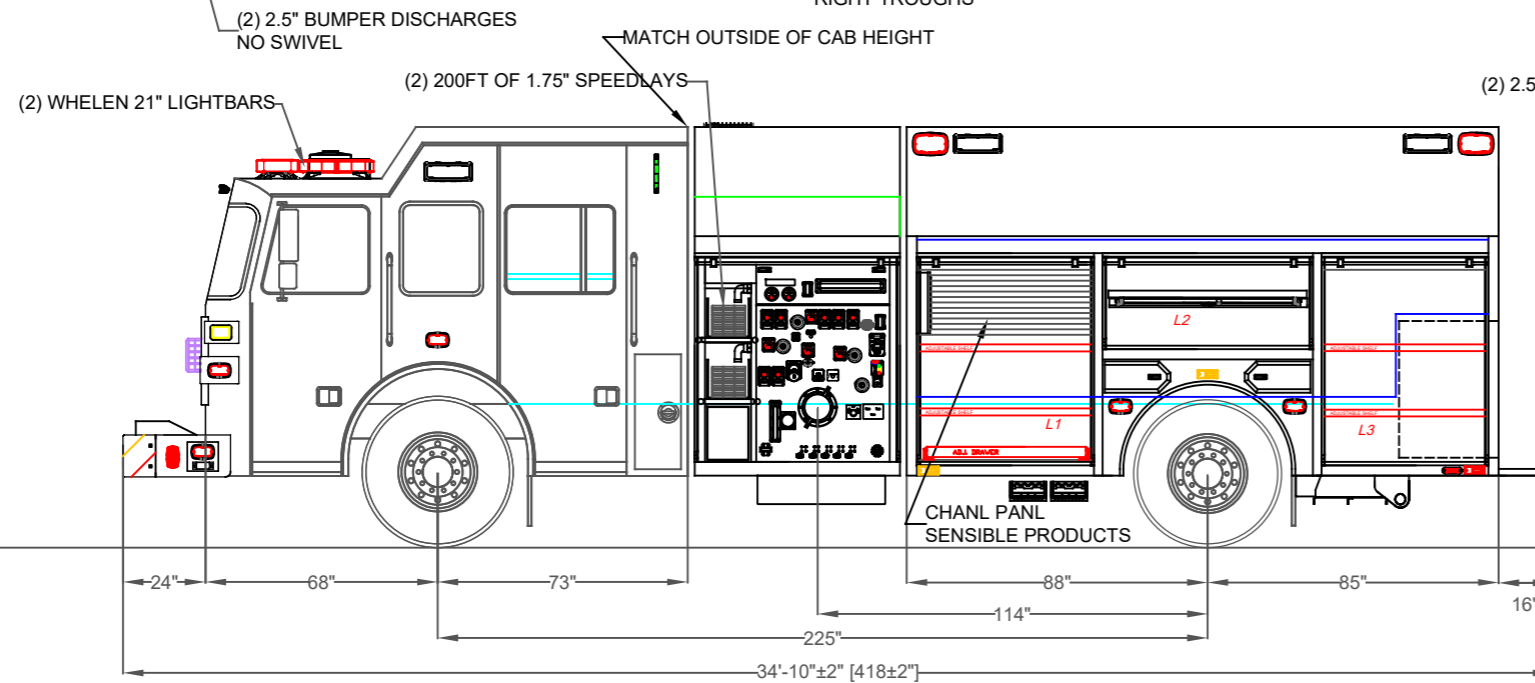

DIMENSIONS SHOWN ON THIS DRAWING ARE APPROXIMATE AND ARE SUBJECT TO MINOR DEVIATIONS DURING CONSTRUCTION.	CUSTOMER APPROVAL		E	CHANGE ORDER E	SED	1/28/20	DRAWN BY:	S.DORFMAN	SUTPHEN EAST 55 INNOVATION DRIVE LAKE ARIEL, PA 1-844-776-2889
	IN THE EVENT OF A DISCREPANCY BETWEEN THE SUTPHEN SPECIFICATIONS AND DRAWING, THE SUTPHEN SPECIFICATIONS SHALL PREVAIL.	NAME:	C	ADD BACKBOARD CHUTE, SPEEDLAY ROLLERS, 2.5" INTAKE GAUGE ON PASSENGER SIDE, MAKE DIVIDER BREAK WIDER	SED	11/22/19	DATE:		
DRAWING IS FOR REFERENCE ONLY. SOME ITEMS PROPOSED MAY NOT BE SHOWN OR NOTED.		TITLE:	B	CHANGE ALTERNATING HEADLIGHTS FROM HIGHBEAMS TO HALOS	SED	10/11/19	MFG. FACILITY:	SUTPHEN EAST LAKE ARIEL, PA	Queen Anne Hillsboro VFC Queen Anne, MD
	DATE:	A	CHANGES FROM PRE-CON	SED	7/5/19	PA-06 Custom Aluminum Pumper			
			REV.	DESCRIPTION	BY	DATE	JWG. NO.:		HS 6536
THIS PRINT IS PROVIDED ON A RESTRICTED BASIS AND IS NOT TO BE USED IN ANY WAY DETRIMENTAL TO THE INTEREST OF SUTPHEN CORPORATION.									