

LEFT SIDE COMPARTMENTATION				
COMPT	DOORS	OPENING DIMENSIONS	INSIDE DIMENSIONS	VOLUME
L1	ROLL-UP	24 3/4" w X 63 3/4" h	30 1/2" w X 72" h X 27 1/4" d	34 CU. FT.
L2	ROLL-UP	57 1/2" w X 33 1/4" h	61 1/2" w X 42 1/2" h X 27 1/4" d	41 CU. FT.
L3	ROLL-UP	48 1/2" w X 63 3/4" h	56 1/2" w X 72" h X 27 1/4" d	64 CU. FT.
LEFT BODY FRAME:				

RIGHT SIDE COMPARTMENTATION				
COMPT	DOORS	OPENING DIMENSIONS	INSIDE DIMENSIONS	VOLUME
R1	ROLL-UP	24 3/4" w X 31 3/4" h	30 1/2" w X 39" h X 27 1/4" d	19 CU. FT.
R2	ROLL-UP	48 1/2" w X 31 3/4" h	56 1/2" w X 39" h X 27 1/4" d	35 CU. FT.
RIGHT BODY FRAME:				

REAR STEP COMPARTMENTS				
COMPT	DOORS	OPENING DIMENSIONS	INSIDE DIMENSIONS	VOLUME
A1	ROLL-UP	37 1/2" w X 29" h	39" h X 40" w X 30 1/2" d	27 CU. FT.

TOTAL STORAGE: 220 cu. ft.

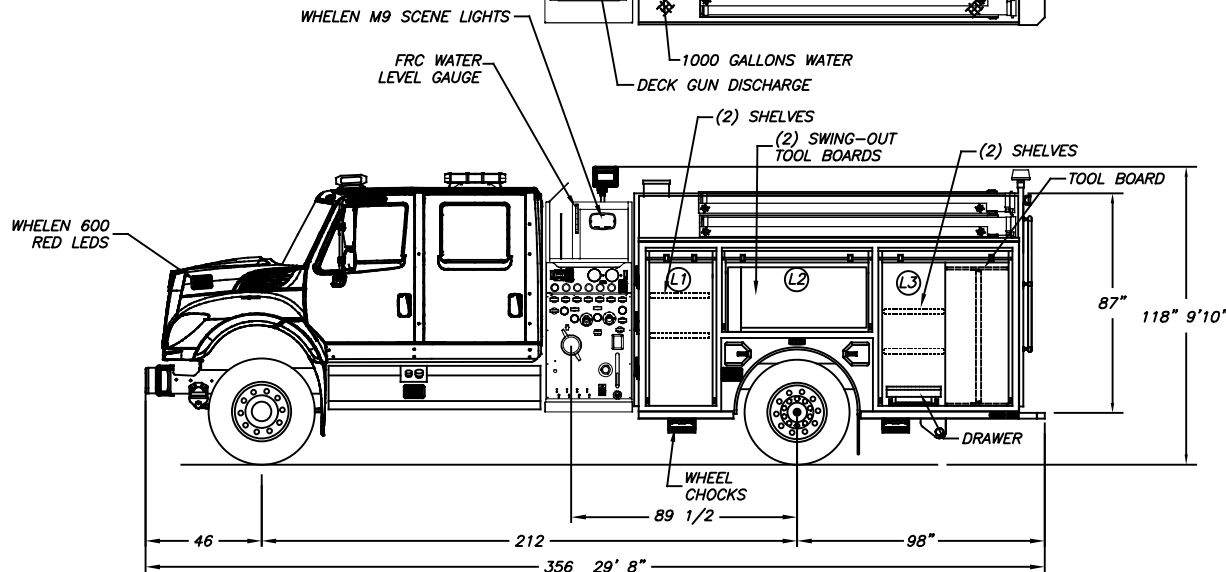
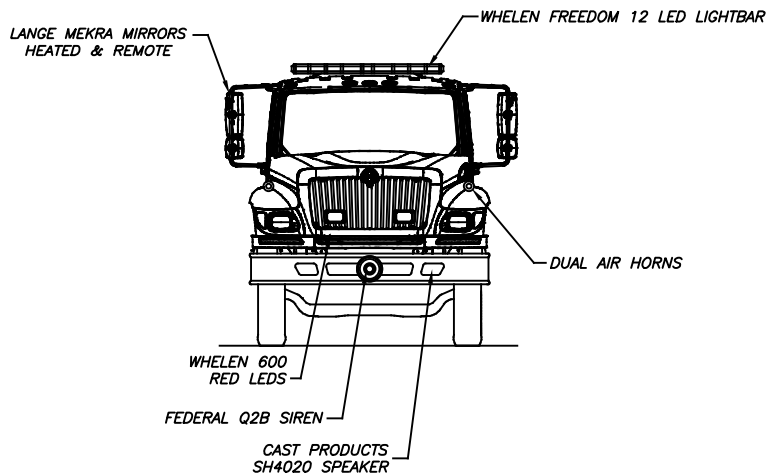
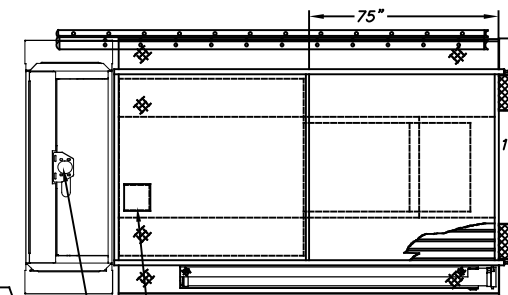

THE INFORMATION PRESENTED ON THIS DOCUMENT IS TO BE USED FOR ILLUSTRATIVE PURPOSES ONLY AND IT MAY NOT REFLECT, AESTHETICALLY OR OTHERWISE, PAST OR PRESENT MANUFACTURED PRODUCTS. SUTPHEN CORPORATION RESERVES THE RIGHT TO MAKE CHANGES IN THE DESIGN OF OUR PRODUCTS AT ANY TIME, WITHOUT NOTIFICATION.

The undersigned approves this data for construction in accordance with any changes as indicated on these drawings.
APPROVED BY: _____ DATE: _____
(Authorized Fire Dept. Representative)
SALES REPRESENTATIVE: _____ DATE: _____

REV.	DESCRIPTION	BY	DATE
A	REVISED PER SHOP ORDER	JNH	11/4/2019

DRAWN BY:
J.HAULMAN
DATE:
10/7/2019
MFG FACILITY:
SPRINGFIELD

SUTPHEN
PHILIPPI VOLUNTEER FIRE DEPARTMENT
PHILIPPI, WV.
PROGRAM 1 COMMERCIAL PUMPER
HS-6528