

Hose Load
 1:800ft of 3"
 2:1000ft of 5"
 3:800ft of 3"

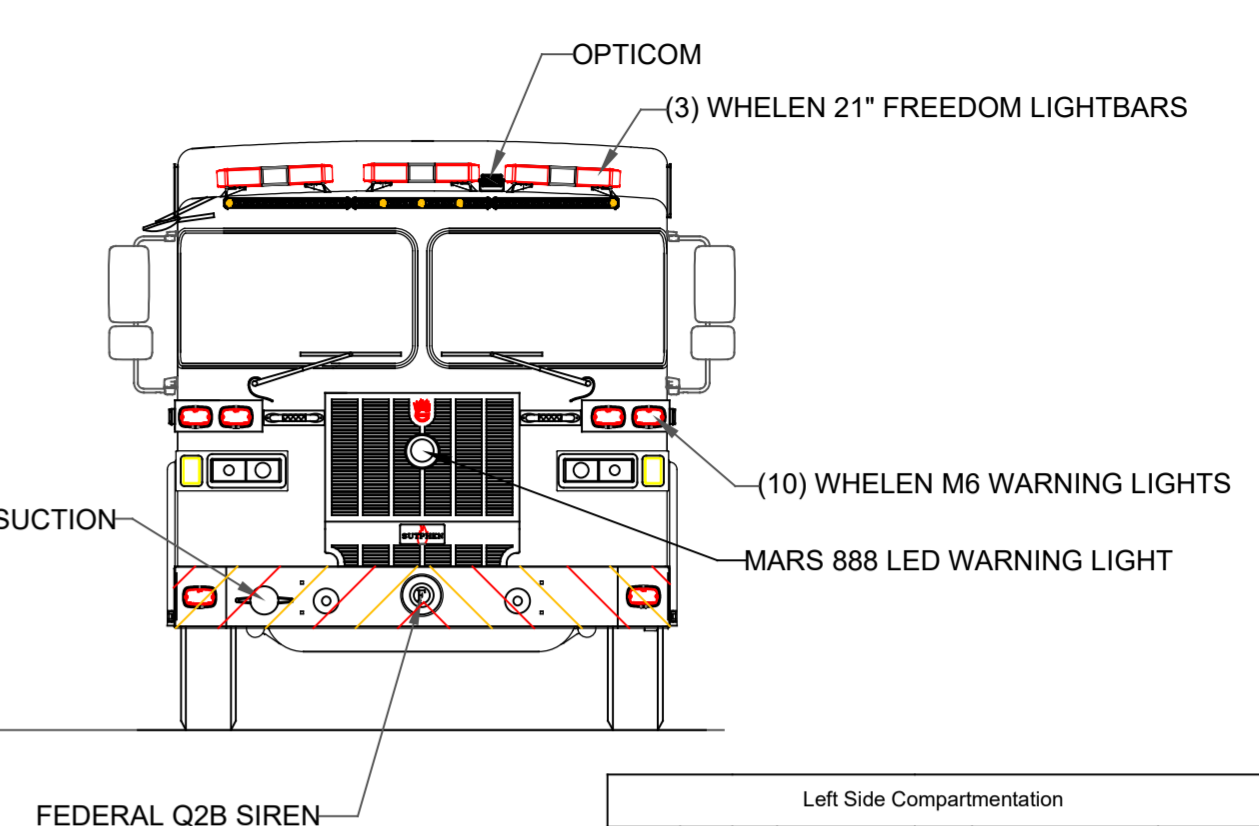

Left Side Compartmentation				
Compt	Doors	Opening Dimensions	Inside Dimensions	Volume
WxHxD				
L1	Hinged	38x61	45x71x24.25/10.25	33.2 CU FT
L2	Hinged	53x29	60x39x10.25	13.9 CU FT
L3	Hinged	48x61	55x71x24.25/10.25	40.5 CU FT
Right Side Compartmentation				
Compt	Doors	Opening Dimensions	Inside Dimensions	Volume
R1	Hinged	38x61	45x45x24.25/10.25	28.4 CU FT
R2	Hinged	53x10	60x14x10.25	5.0 CU FT
R3	Hinged	48x61	55x45x24.25/10.25	34.7 CU FT
Rear Compartmentation				
Compt	Doors	Opening Dimensions	Inside Dimensions	Volume
A1	Hinged	41x20	48x24x27.25	18.2 CU FT

Hale Qmax 1500 single stage
Water Tank Capacity 750 gal
Foam Tank Capacity 30 gal

Total Volume
173.8 CU FT

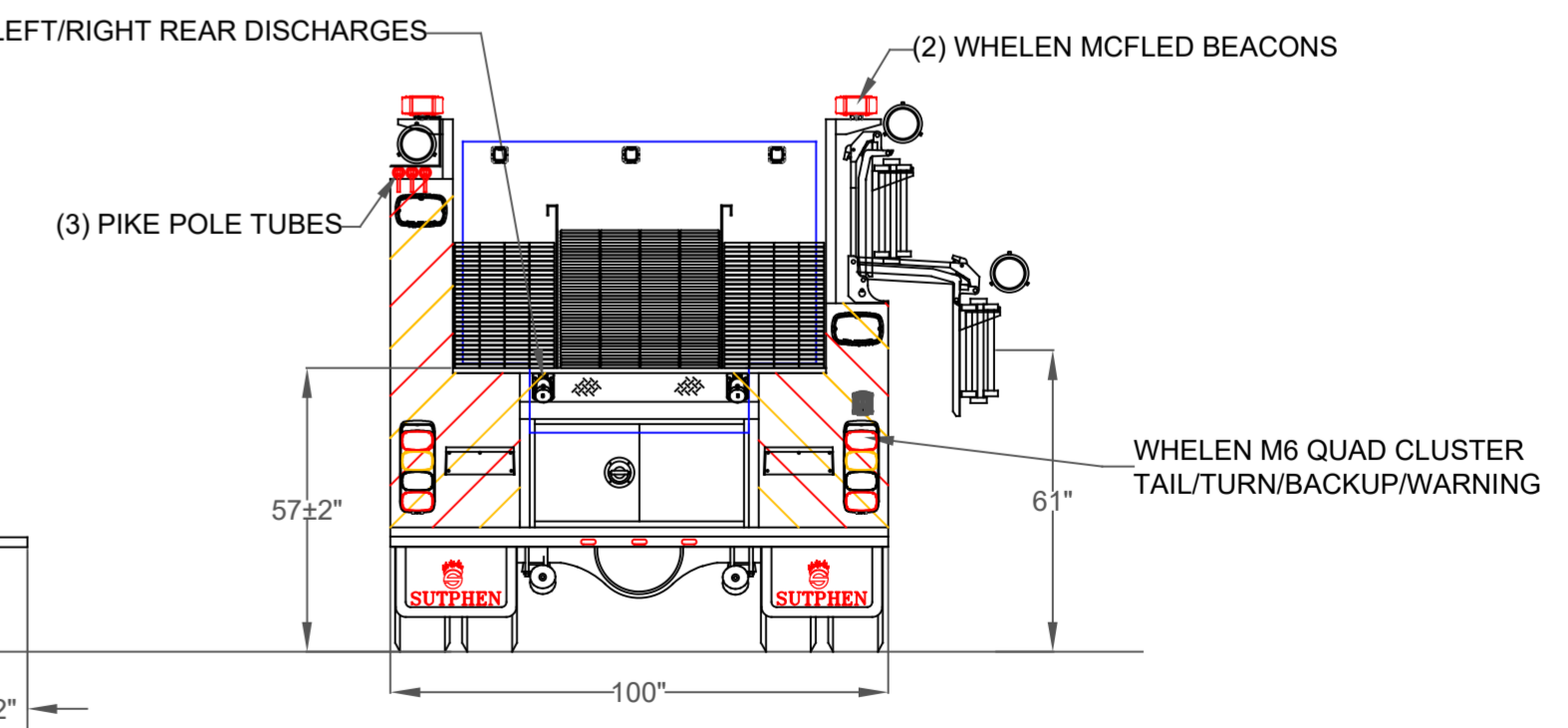
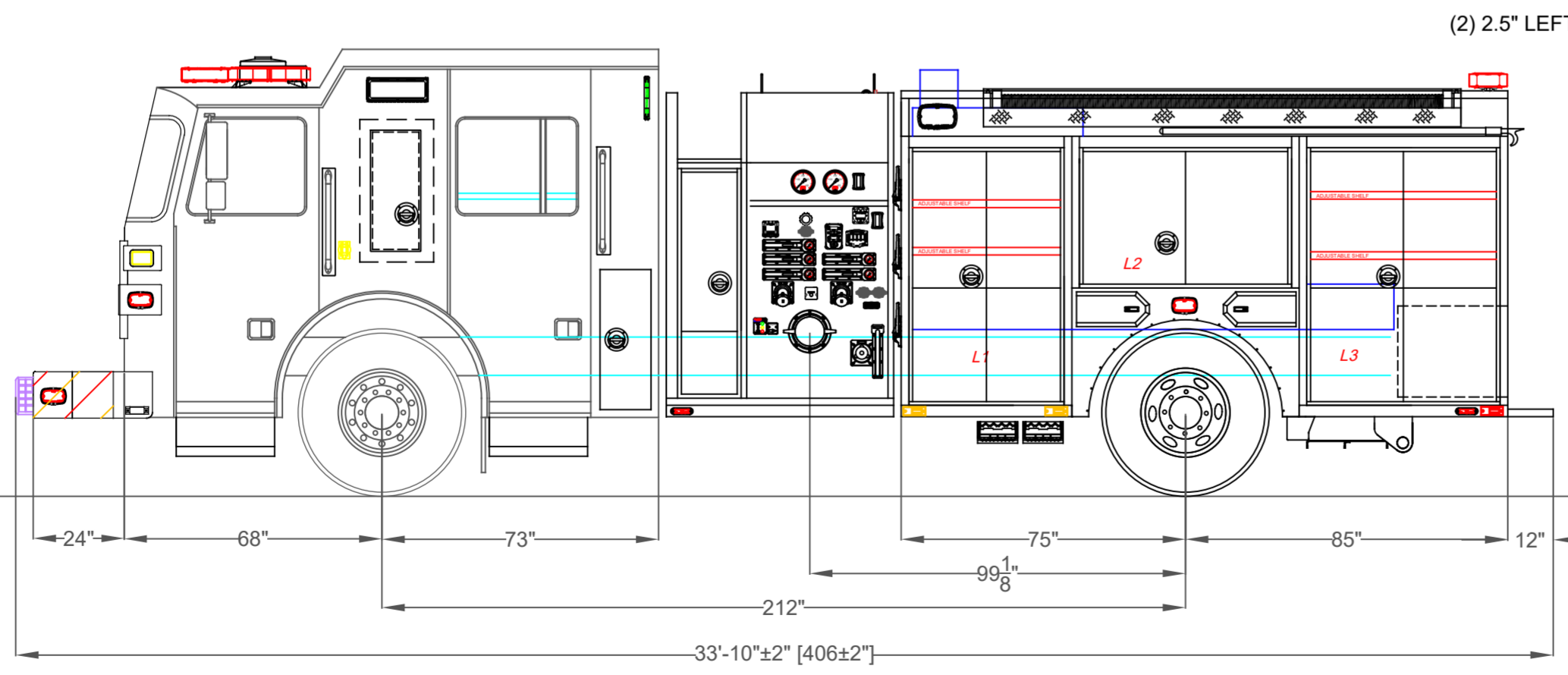

DIMENSIONS SHOWN ON THIS DRAWING ARE APPROXIMATE AND ARE SUBJECT TO MINOR DEVIATIONS DURING CONSTRUCTION. IN THE EVENT OF A DISCREPANCY BETWEEN THE SUTPHEN SPECIFICATIONS AND DRAWING, THE SUTPHEN SPECIFICATIONS SHALL PREVAIL. DRAWING IS FOR REFERENCE ONLY. SOME ITEMS PROPOSED MAY NOT BE SHOWN OR NOTED.	CUSTOMER APPROVAL						DRAWN BY: J. Gordon	SUTPHEN EAST 55 INNOVATION DRIVE LAKE ARIEL, PA 1-844-776-2889 Bloomingdale Fire Dept. Bloomingdale, IL Custom Stainless Pumper
	NAME:						DATE:	
	TITLE:						MFG. FACILITY:	SUTPHEN EAST LAKE ARIEL, PA
	DATE:						DWG. NO.:	HS 6527
THIS PRINT IS PROVIDED ON A RESTRICTED BASIS AND IS NOT TO BE USED IN ANY WAY DETRIMENTAL TO THE INTEREST OF SUTPHEN CORPORATION.								