

Left Side Compartmentation				
Compt	Doors	Opening Dimensions	Inside Dimensions	Volume
L1	Hinge	41x50	48x60x8.25/24.25	24.25 CU FT
L2	Hinge	23x26	30x36x24.5	15.2 CU FT
L3	Hinge	23x26	30x36x24.5	15.2 CU FT

Right Side Compartmentation				
Compt	Doors	Opening Dimensions	Inside Dimensions	Volume
R1	Hinge	41x26	48x36x24.25	24.25 CU FT
R2	Hinge	23x26	30x36x24.5	15.2 CU FT
R3	Hinge	23x26	30x36x24.5	15.2 CU FT

HALE DSD 1250 GPM SINGLE STAGE PUMP  
3000 GALLONS WETSIDE TANK

Total Volume	109.3 CU Ft
--------------	-------------

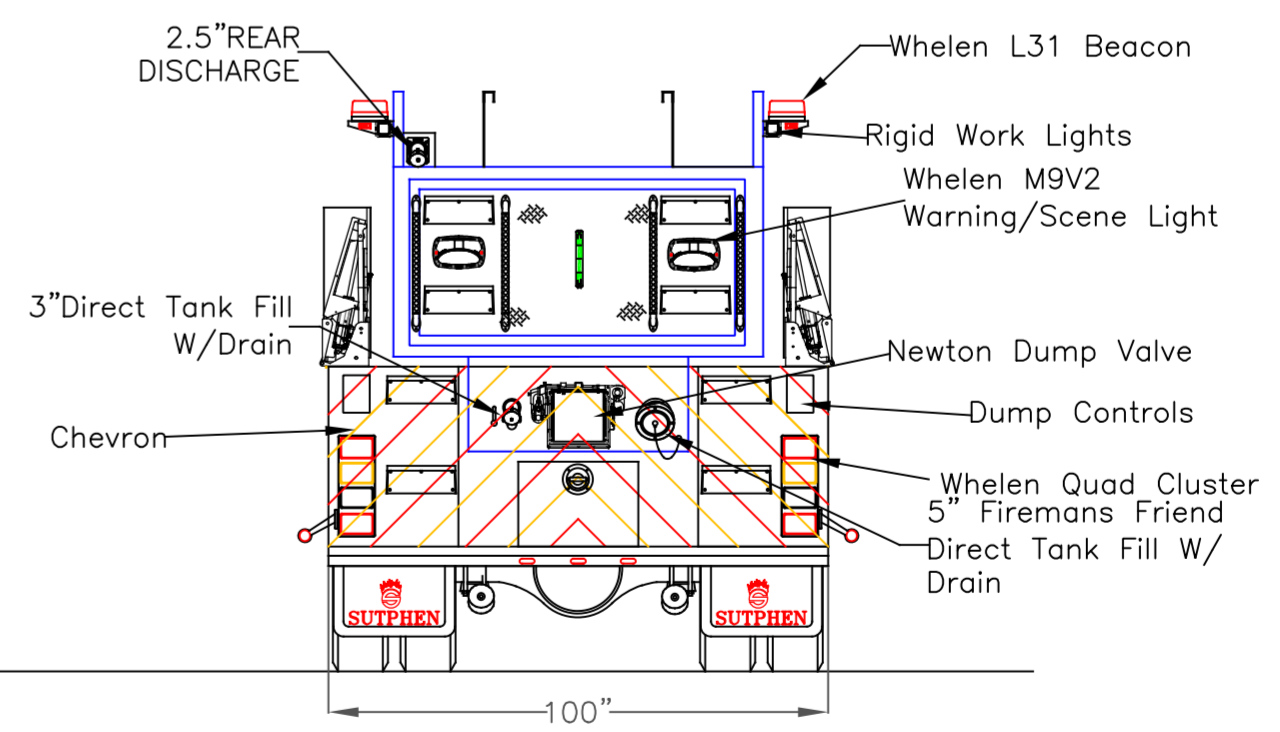
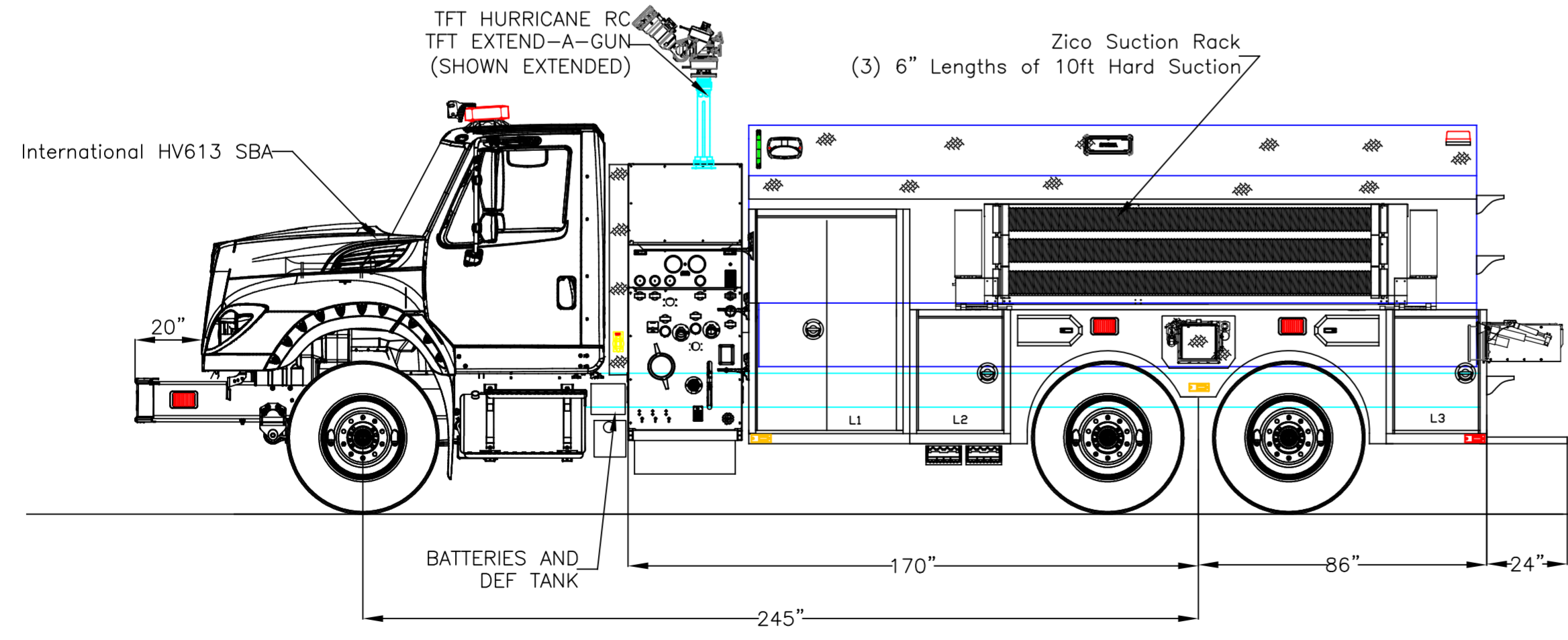

DIMENSIONS SHOWN ON THIS DRAWING ARE APPROXIMATE AND ARE SUBJECT TO MINOR DEVIATIONS DURING CONSTRUCTION.

IN THE EVENT OF A DISCREPANCY BETWEEN THE SUTPHEN SPECIFICATIONS AND DRAWING, THE SUTPHEN SPECIFICATIONS SHALL PREVAIL.

DRAWING IS FOR REFERENCE ONLY. SOME ITEMS PROPOSED MAY NOT BE SHOWN OR NOTED.

**CUSTOMER APPROVAL**

NAME: \_\_\_\_\_

TITLE: \_\_\_\_\_

DATE: \_\_\_\_\_

REV.	DESCRIPTION	BY	DATE
REV C.	ADD HOSEBED 2.5" DISCHARGE	SED	10/17/19
REV C.	ADD HOSEBED 2.5" DISCHARGE	SED	10/17/19
REV A.	CHANGES FROM PRE-CON	SED	7-9-19

THIS PRINT IS PROVIDED ON A RESTRICTED BASIS AND IS NOT TO BE USED IN ANY WAY DETRIMENTAL TO THE INTEREST OF SUTPHEN CORPORATION.

DRAWN BY: S. DORFMAN

DATE: 08/27/17

MFG. FACILITY: SUTPHEN EAST LAKE ARIEL, PA

DWG. NO.: HS 6496-6497

**SUTPHEN EAST**  
55 INNOVATION DRIVE  
LAKE ARIEL, PA  
1-844-776-2889

**PALM BEACH COUNTY**  
WEST PALM BEACH, FL

STAINLESS WETSIDE TANKER