

LEFT SIDE COMPARTMENTATION

COMPT	DOORS	INSIDE DIMENSIONS	DOOR OPENING DIMENSIONS	VOLUME
L1	ROLL-UP	40"W X 66"H X 26"D	37 1/2"W X 56 1/2"H	28.5 CU. FT.
L2	ROLL-UP	59"W X 31 1/2"H X 11"D	56 1/4"W X 27"H	13.7 CU. FT.
L3	ROLL-UP	40"W X 66"H X 26"D	37 1/2"W X 56 1/2"H	28.5 CU. FT.

11" DEEP, UPPER

RIGHT SIDE COMPARTMENTATION

COMPT	DOORS	INSIDE DIMENSIONS	DOOR OPENING DIMENSIONS	VOLUME
R1	ROLL-UP	40"W X 40"H X 26"D	37 1/2"W X 36 1/2"H	24 CU. FT.
R2	ROLL-UP	40"W X 40"H X 26"D	37 1/2"W X 30 1/2"H	24 CU. FT.
	ROLL-UP			

11" DEEP, UPPER

REAR STEP COMPARTMENT

COMPT	DOORS	INSIDE DIMENSIONS	DOOR OPENING DIMENSIONS	VOLUME
A1	ROLL-UP	39 1/2"W X 44"H X 31"D	36 3/4"W X 34 1/4"H	31.2 CU. FT.

BASE STORAGE: 150 CU. FT.

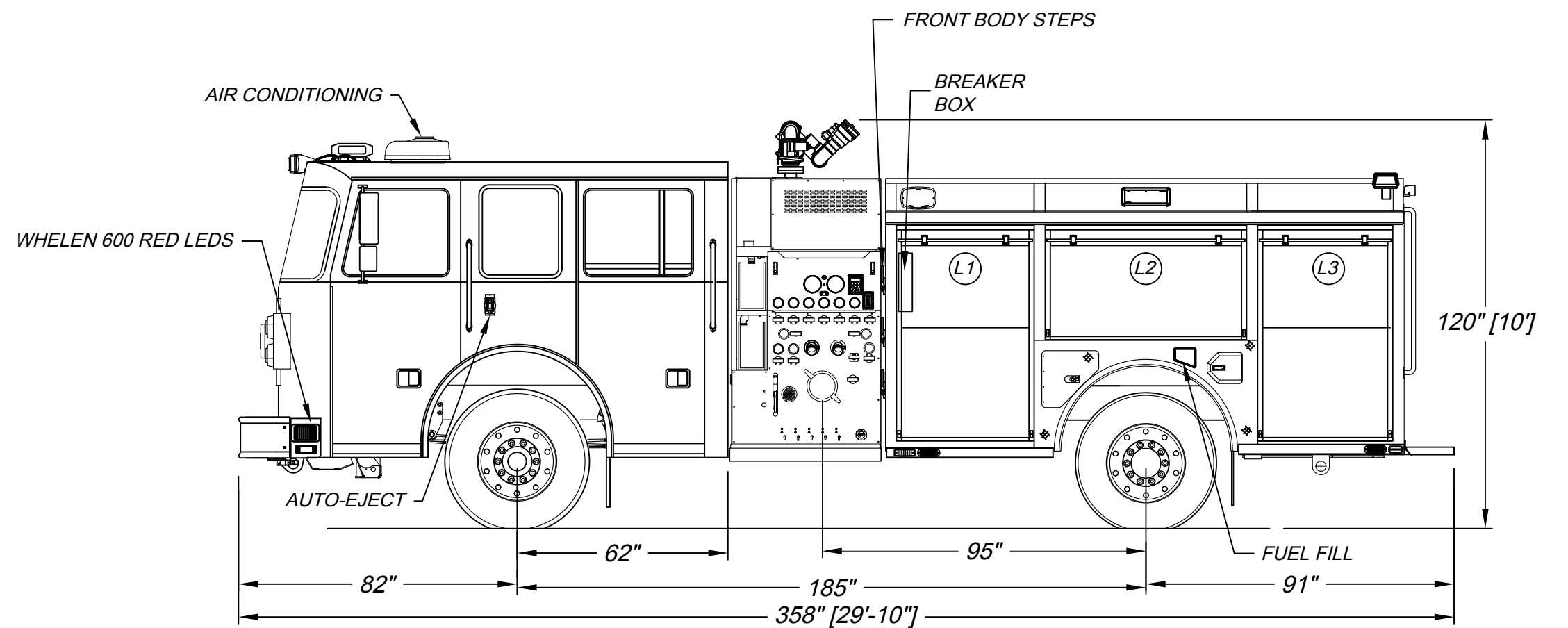
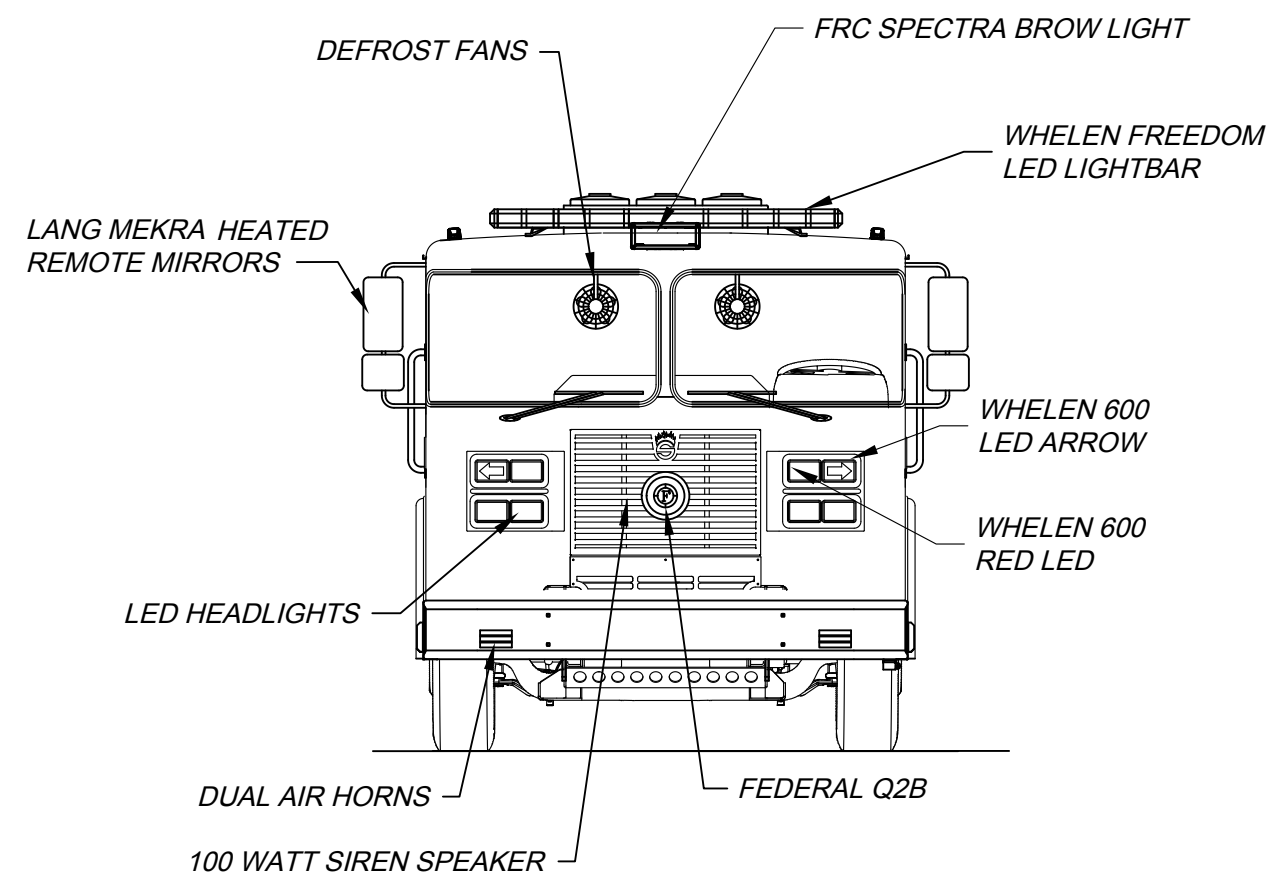
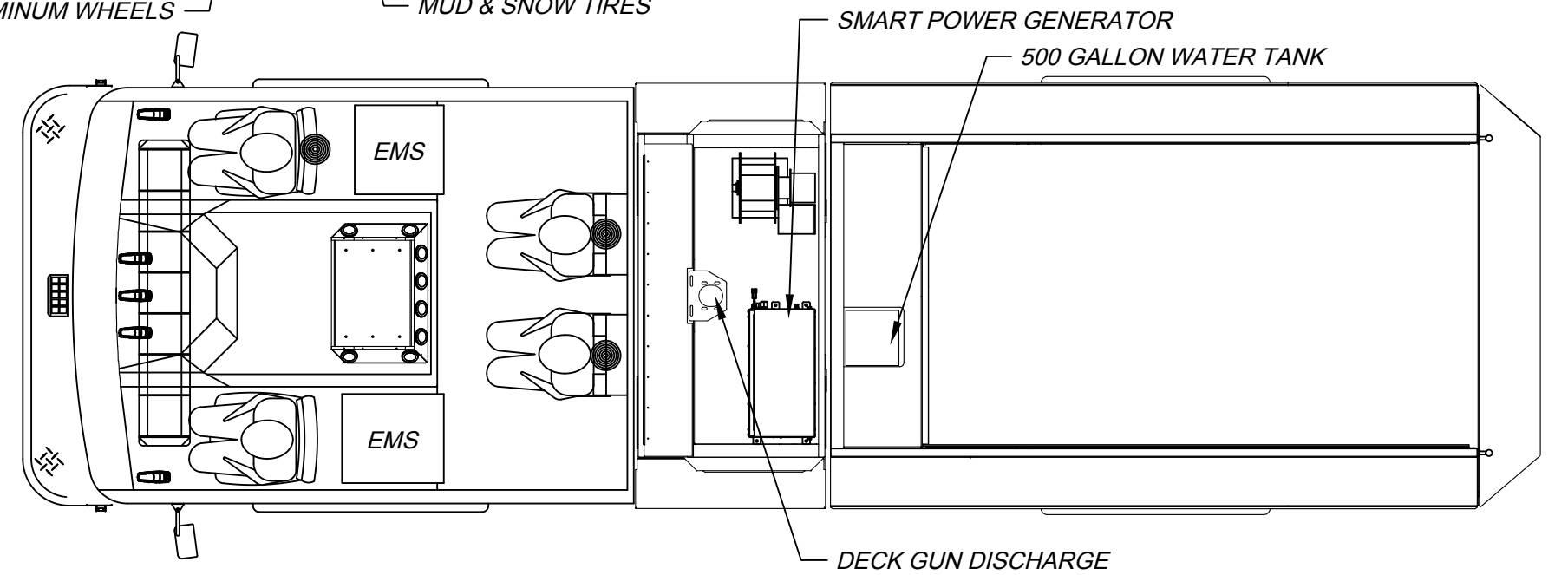

DIMENSIONS SHOWN ON THIS DRAWING ARE APPROXIMATE AND ARE SUBJECT TO MINOR DEVIATIONS DURING CONSTRUCTION.

IN THE EVENT OF A DISCREPANCY BETWEEN THE SUTPHEN SPECIFICATIONS AND DRAWING, THE SUTPHEN SPECIFICATIONS SHALL PREVAIL.

DRAWING IS FOR REFERENCE ONLY. SOME ITEMS PROPOSED MAY NOT BE SHOWN OR NOTED.

CUSTOMER APPROVAL

NAME: _____
 TITLE: _____
 DATE: _____

REV.	DESCRIPTION	BY	DATE
B	Revised per shop order	JNH	4/11/2019
A	Revised per shop order	JNH	3/28/2019

DRAWN BY:
 J.HAULMAN
 DATE:
 2/11/2019
 MFG. FACILITY:
 SPRINGFIELD

SUTPHEN
 WHEELING FIRE DEPARTMENT
 WHEELING, WV.
 PROGRAM 1 CUSTOM PUMPER
 HS-6457