

Left Side Compartmentation				
Compt	Doors	Opening Dimensions	Inside Dimensions	Volume
WxHxD				
L1	Roll Up	23x26	28.75x36x24.25	14.5 CU FT
L2	Roll Up	23x26	28.75x36x24.25	14.5 CU FT
Right Side Compartmentation				
Compt	Doors	Opening Dimensions	Inside Dimensions	Volume
R1	Roll Up	76x26	83.75x36x24.25	42.3 CU FT
R2	Roll Up	23x26	28.75x36x24.25	14.5 CU FT

Hale APS Sidekick 750 gpm
Water Tank Capacity 3000 gal

Total Volume
85.9 CU FT

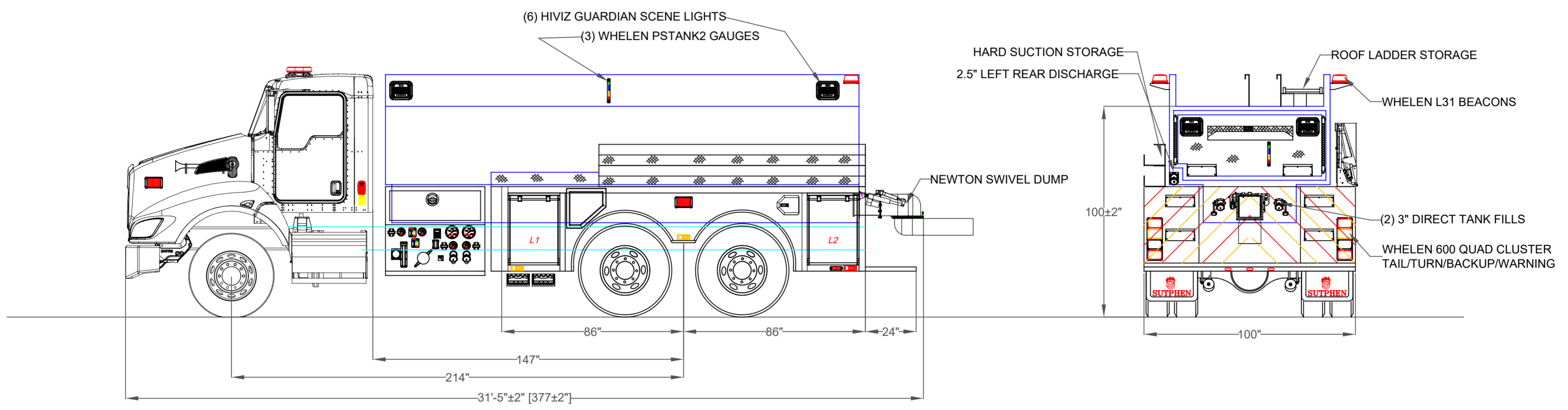

DIMENSIONS SHOWN ON THIS DRAWING ARE APPROXIMATE AND ARE SUBJECT TO MINOR DEVIATIONS DURING CONSTRUCTION.

IN THE EVENT OF A DISCREPANCY BETWEEN THE SUTPHEN SPECIFICATIONS AND DRAWING, THE SUTPHEN SPECIFICATIONS SHALL PREVAIL.

DRAWING IS FOR REFERENCE ONLY. SOME ITEMS PROPOSED MAY NOT BE SHOWN OR NOTED.

CUSTOMER APPROVAL

NAME: _____

TITLE: _____

DATE: _____

REV.	DESCRIPTION	BY	DATE
A	UPDATED TO MATCH REV A SHOP ORDER	JVG	01/17/2019

THIS PRINT IS PROVIDED ON A RESTRICTED BASIS AND IS NOT TO BE USED IN ANY WAY DETRIMENTAL TO THE INTEREST OF SUTPHEN CORPORATION.

DRAWN BY: J. Gordon

DATE: 12/12/2018

MFG. FACILITY: SUTPHEN EAST LAKE ARIEL, PA

DWG. NO.: HS 6443

SUTPHEN EAST
55 INNOVATION DRIVE
LAKE ARIEL, PA
1-844-776-2889

Fairview Firemens Relief Association
Fairview, PA

SWT-05B Commercial Wetside Tanker