

LEFT SIDE COMPARTMENTATION				
COMPT	DOORS	OPENING DIMENSIONS	INSIDE DIMENSIONS	VOLUME
L1	ROLL-UP	30.5" W X 57.4" H	36.1" W X 68" H X 27.3" D	27.6 CU. FT. (36" H X 13.5" D UPPER)
L2	ROLL-UP	57.5" W X 28.2" H	61.6" W X 36.8" H X 13.5" D	29.8 CU. FT.
L3	ROLL-UP	30.5" W X 57.4" H	36.1" W X 68" H X 27.3" D	27.6 CU. FT. (36" H X 13.5" D UPPER)
H1	LIFT UP	(2) 60" W X 12.5" D	135.5" W X 15" H X 13.5" D	15.9 CU. FT.

RIGHT SIDE COMPARTMENTATION				
COMPT	DOORS	OPENING DIMENSIONS	INSIDE DIMENSIONS	VOLUME
R1	ROLL-UP	30.5" W X 22.4" H	36.1" W X 31" H X 27.3" D	17.7 CU. FT.
R2	ROLL-UP	30.5" W X 22.4" H	36.1" W X 31" H X 27.3" D	17.7 CU. FT.

REAR STEP COMPARTMENTS				
COMPT	DOORS	OPENING DIMENSIONS	INSIDE DIMENSIONS	VOLUME
A1	ROLL-UP	33" W X 21" H	26" H X 37" W X 28" D	10.4 CU. FT.

TOTAL: 146.7 CU. FT.

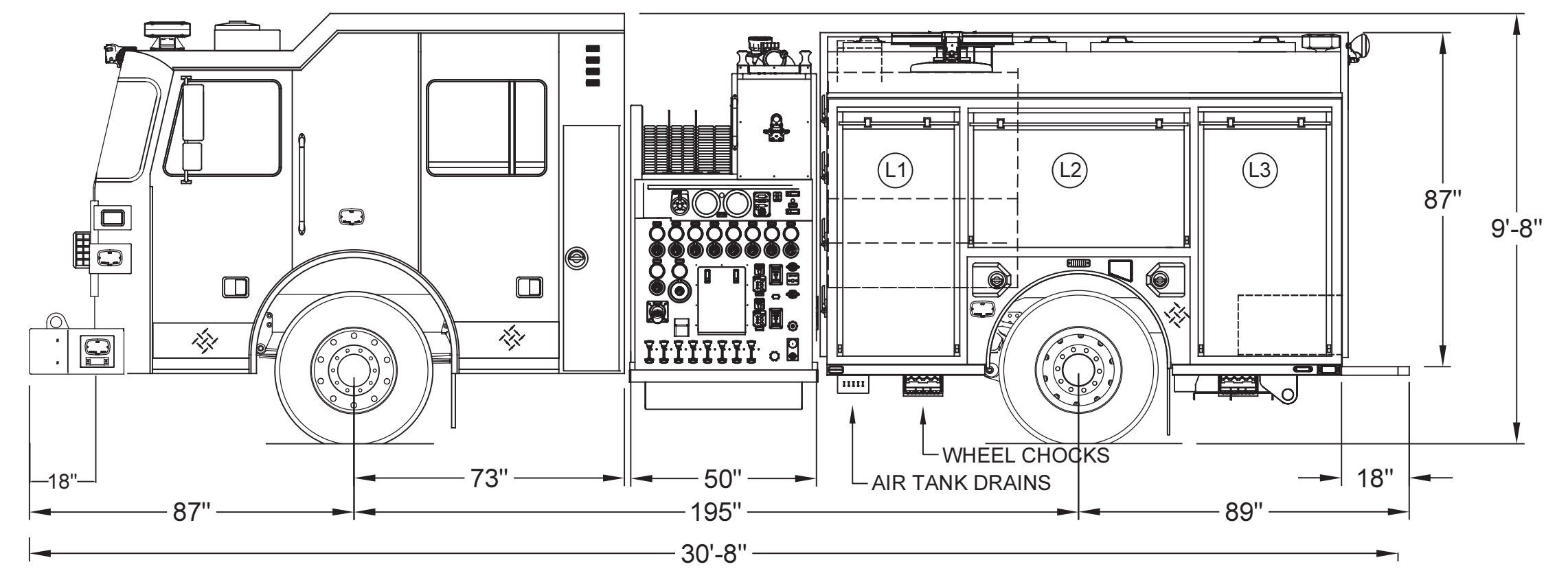
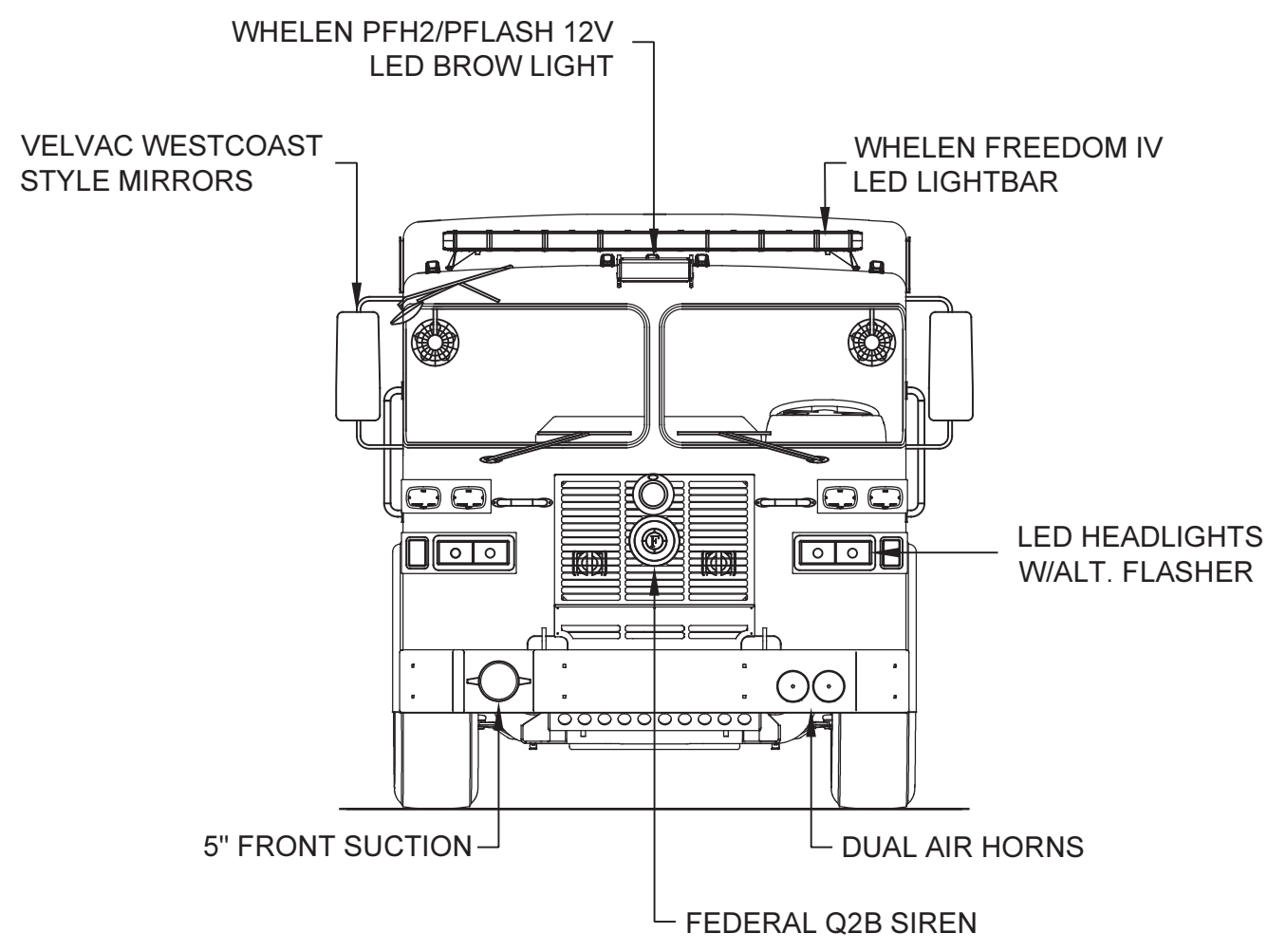

DIMENSIONS SHOWN ON THIS DRAWING ARE APPROXIMATE AND ARE SUBJECT TO MINOR DEVIATIONS DURING CONSTRUCTION.

IN THE EVENT OF A DISCREPANCY BETWEEN THE SUTPHEN SPECIFICATIONS AND DRAWING, THE SUTPHEN SPECIFICATIONS SHALL PREVAIL.

DRAWING IS FOR REFERENCE ONLY. SOME ITEMS PROPOSED MAY NOT BE SHOWN OR NOTED.

CUSTOMER APPROVAL

NAME: _____

TITLE: _____

DATE: _____

H	UPDATED DRAWING TO REFLECT COMPONENT REPORT CHANGES	MJC	09/24/19
G	UPDATED DRAWING TO REFLECT COMPONENT REPORT CHANGES	MJC	08/02/19
F	UPDATED DRAWING TO REFLECT COMPONENT REPORT CHANGES	MJC	07/15/19
E	UPDATED DRAWING TO REFLECT COMPONENT REPORT CHANGES	MJC	06/17/19
REV.	DESCRIPTION	BY	DATE

THIS PRINT IS PROVIDED ON A RESTRICTED BASIS AND IS NOT TO BE USED IN ANY WAY DETRIMENTAL TO THE INTEREST OF SUTPHEN CORPORATION.

DRAWN BY: M. CLARK

DATE: 10/19/18

MFG. FACILITY: DUBLIN



DEKALB COUNTY FIRE RESCUE
STONE MOUNTAIN, GA

CUSTOM PUMPER

DWG. NO.: HS-6419-22