

LEFT SIDE COMPARTMENTS				
COMPT	DOORS	OPENING DIMENSIONS	INSIDE DIMENSIONS	VOLUME
L1	ROLL-UP	35.5" w X 58.2" h	43.1" w X 66" h X 27.3" d	40.8 CU. FT. (10" h X 10.5" d UPPER)
L2	ROLL-UP	55.5" w X 29.0" h	61.6" w X 36.8" h X 27.3" d	29.8 CU. FT. (10" h X 10.5" d UPPER)
L3	ROLL-UP	48.5" w X 58.2" h	53.4" w X 66" h X 27.3" d	50.5 CU. FT. (10" h X 10.5" d UPPER)

RIGHT SIDE COMPARTMENTS				
COMPT	DOORS	OPENING DIMENSIONS	INSIDE DIMENSIONS	VOLUME
R1	ROLL-UP	35.5" w X 58.2" h	43.1" w X 66" h X 27.3" d	31.1 CU. FT. (33" h X 10.5" d UPPER)
R2	ROLL-UP	55.5" w X 29.0" h	61.6" w X 36.8" h X 10.5" d	13.8 CU. FT.
R3	ROLL-UP	48.5" w X 58.2" h	53.4" w X 66" h X 27.3" d	38.6 CU. FT. (33" h X 10.5" d UPPER)

REAR STEP COMPARTMENT				
COMPT	DOORS	OPENING DIMENSIONS	INSIDE DIMENSIONS	VOLUME
A1	ROLL-UP	37.5" w X 32.8" h	40" h X 40" w X 31" d	28.7 CU. FT.
TOTAL:				233.3 CU. FT.

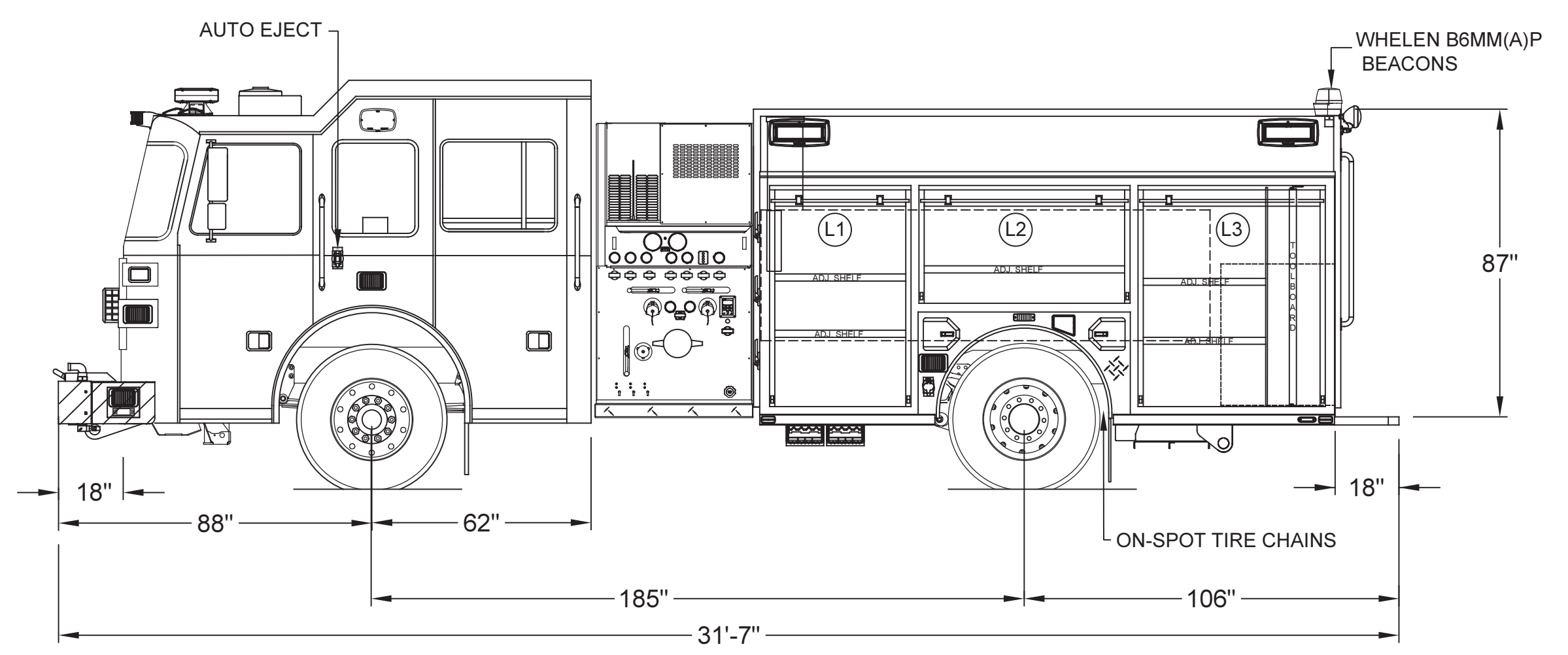
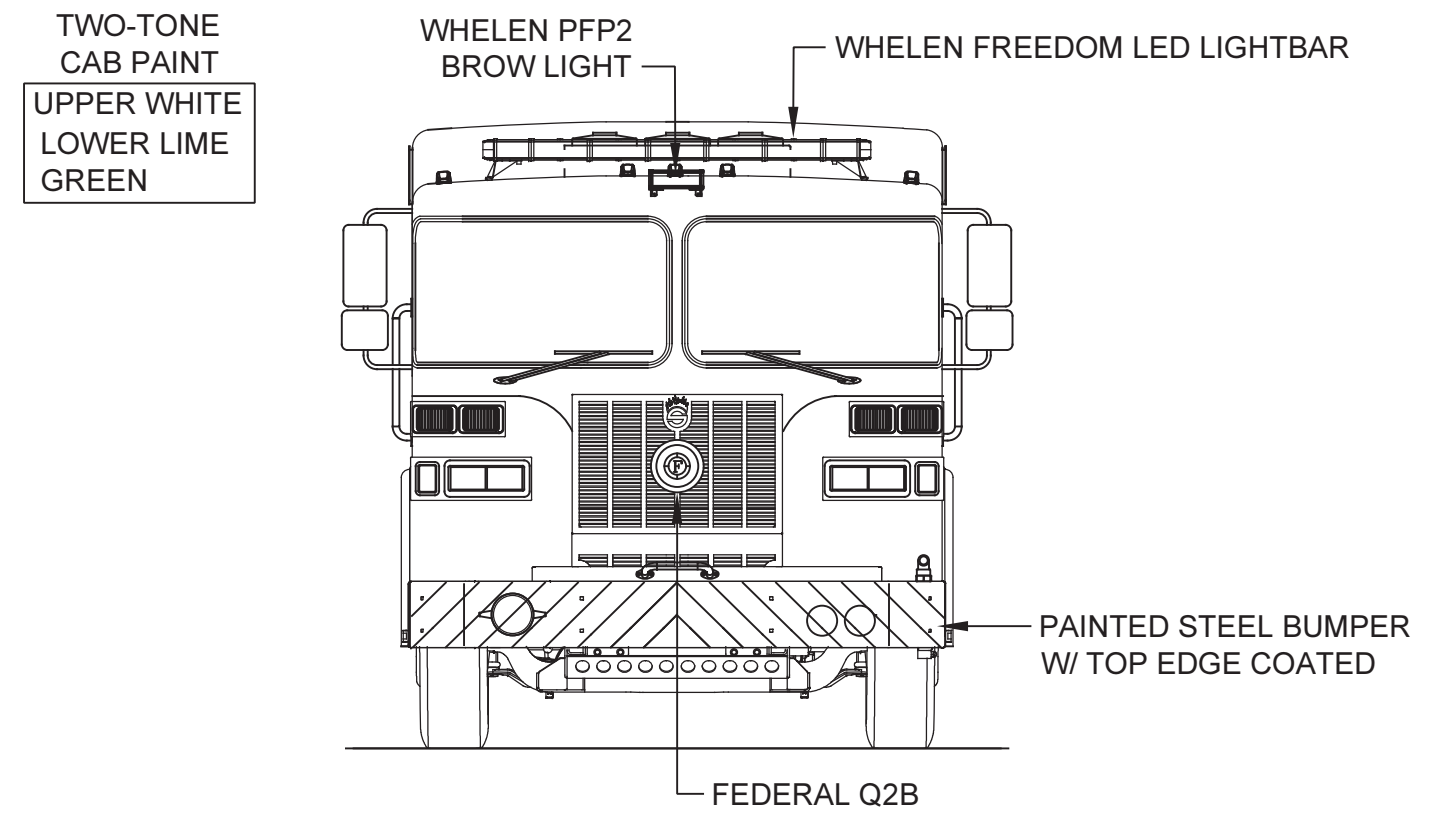
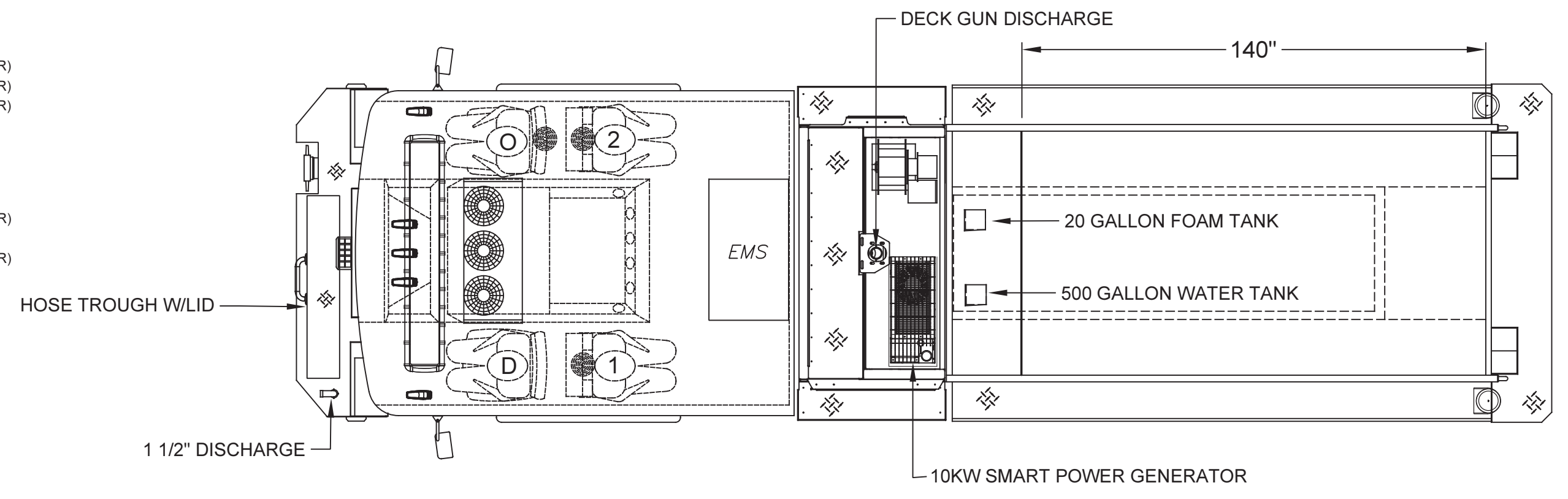

DIMENSIONS SHOWN ON THIS DRAWING ARE APPROXIMATE AND ARE SUBJECT TO MINOR DEVIATIONS DURING CONSTRUCTION.

IN THE EVENT OF A DISCREPANCY BETWEEN THE SUTPHEN SPECIFICATIONS AND DRAWING, THE SUTPHEN SPECIFICATIONS SHALL PREVAIL.

DRAWING IS FOR REFERENCE ONLY. SOME ITEMS PROPOSED MAY NOT BE SHOWN OR NOTED.

CUSTOMER APPROVAL

NAME: _____

TITLE: _____

DATE: _____

REV.	DESCRIPTION	BY	DATE
D	UPDATE VIEW OF FRONT BUMPER / COMPONENT REPORT UPDATED	MJC	09/23/19
C	UPDATE VIEW OF FRONT BUMPER / COMPONENT REPORT UPDATED	MJC	09/4/19
B	DELETE BLIND SPOT MIRROR / COMPONENT REPORT UPDATED	MJC	7/31/19
A	AFTER-PRE-CON	MJC	4/6/19

DRAWN BY: M.CLARK

DATE: 6/11/18

MFG. FACILITY: DUBLIN

SUTPHEN

BRADLEY IAP FIRE DEPARTMENT
WINDSOR LOCKS, CT

CUSTOM PUMPER - S2 BODY

DWG. NO.: HS-6416

THIS PRINT IS PROVIDED ON A RESTRICTED BASIS AND IS NOT TO BE USED IN ANY WAY DETRIMENTAL TO THE INTEREST OF SUTPHEN CORPORATION.