

LEFT SIDE COMPARTMENTS				
COMPT	DOORS	OPENING DIMENSIONS	INSIDE DIMENSIONS	VOLUME
L1	SINGLE	23.5" w X 58.4" h	31.1" w X 66" h X 27.3" d	29.4 CU. FT. (10" h X 10.5" d UPPER)
L2	LIFT-UP	55" w X 31.9" h	61.6" w X 36.8" h X 27.3" d	29.8 CU. FT. (10" h X 10.5" d UPPER)
L3	DOUBLE	48.5" w X 58.4" h	53.4" w X 66" h X 27.3" d	50.5 CU. FT. (10" h X 10.5" d UPPER)

RIGHT SIDE COMPARTMENTS				
COMPT	DOORS	OPENING DIMENSIONS	INSIDE DIMENSIONS	VOLUME
R1	SINGLE	23.5" w X 52.4" h	31.1" w X 60" h X 27.3" d	21.3 CU. FT. (27" h X 10.5" d UPPER)
R2	LIFT-UP	55" w X 25.9" h	61.6" w X 30.8" h X 10.5" d	11.5 CU. FT. (27" h X 10.5" d UPPER)
R3	DOUBLE	48.5" w X 52.4" h	53.4" w X 60" h X 27.3" d	36.6 CU. FT. (27" h X 10.5" d UPPER)

REAR STEP COMPARTMENT				
COMPT	DOORS	OPENING DIMENSIONS	INSIDE DIMENSIONS	VOLUME
A1	ROLL-UP	37.5" w X 32.8" h	40" h X 40" w X 31" d	28.7 CU. FT.

TOTAL: 207.8 CU. FT.

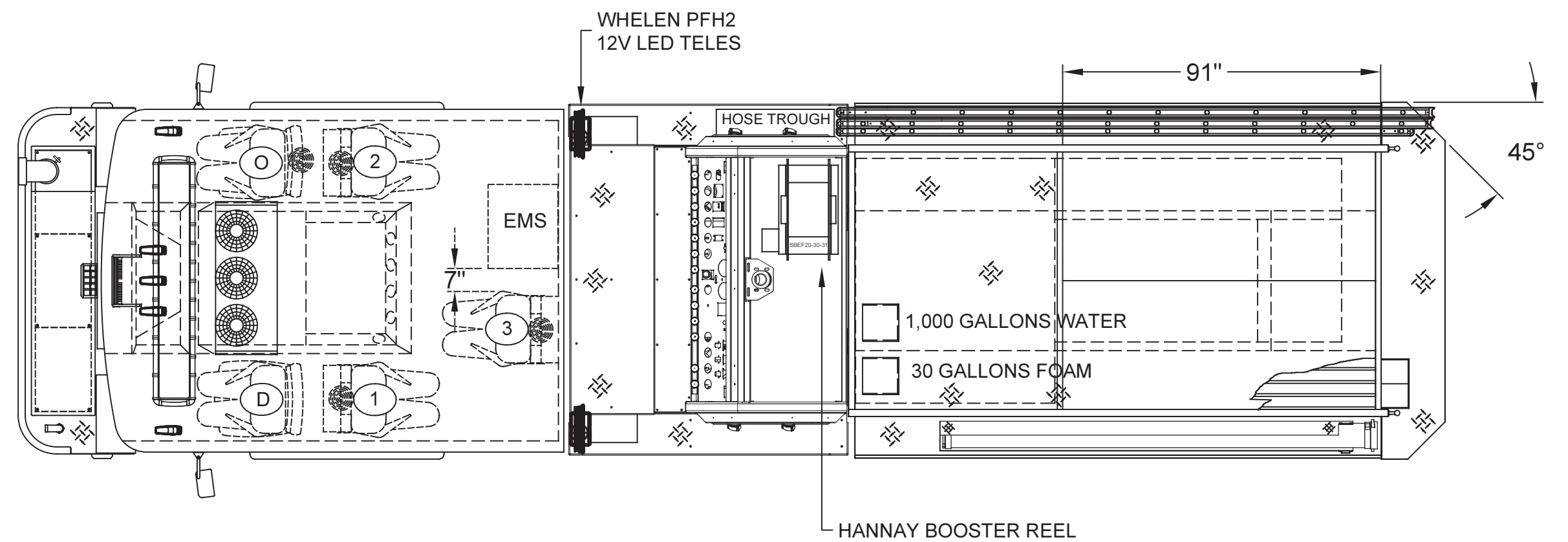

TWO-TONE CAB PAINT
PAINT BREAK OPTION #1
WHITE OVER RED

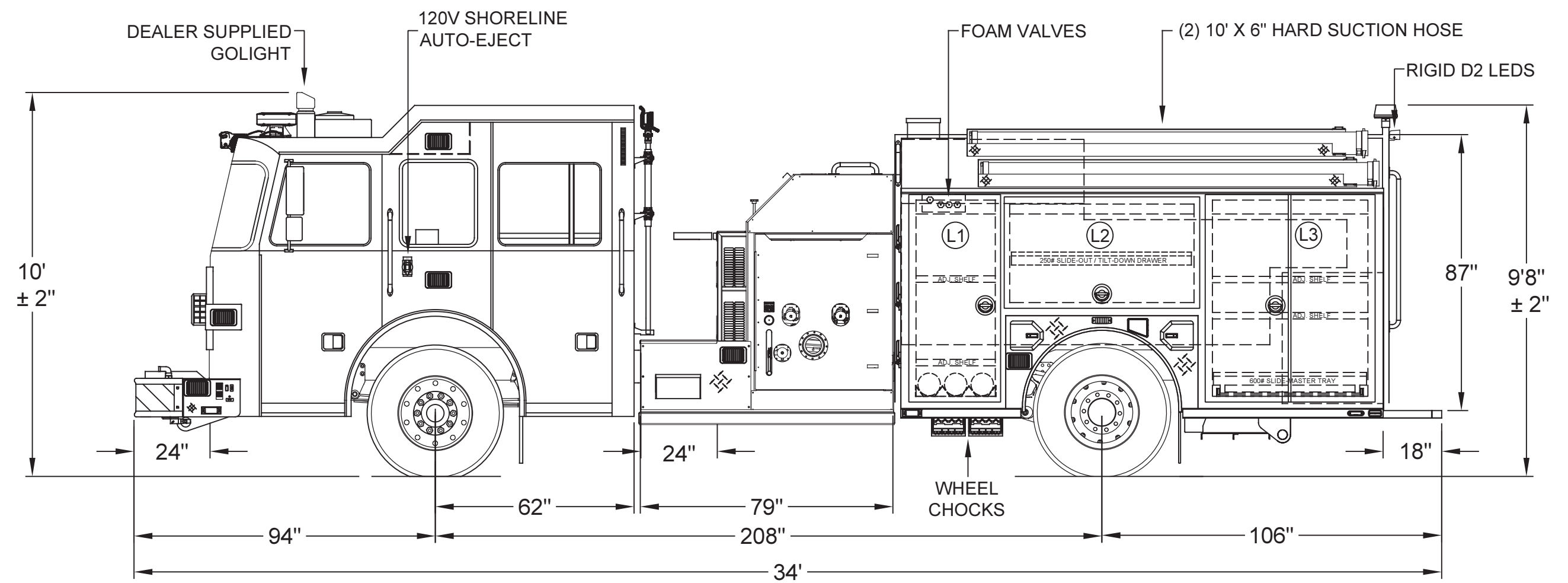
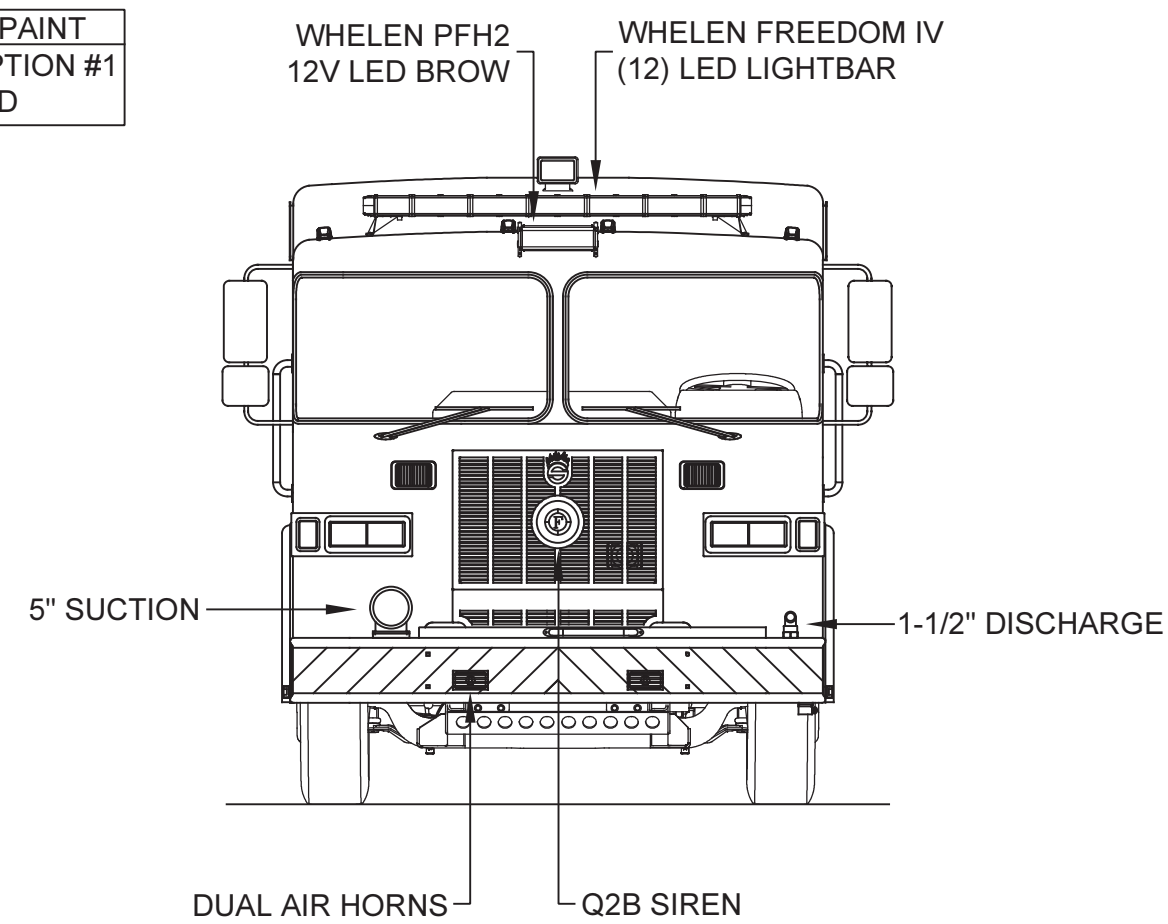

DIMENSIONS SHOWN ON THIS DRAWING ARE APPROXIMATE AND ARE SUBJECT TO MINOR DEVIATIONS DURING CONSTRUCTION.

IN THE EVENT OF A DISCREPANCY BETWEEN THE SUTPHEN SPECIFICATIONS AND DRAWING, THE SUTPHEN SPECIFICATIONS SHALL PREVAIL.

DRAWING IS FOR REFERENCE ONLY. SOME ITEMS PROPOSED MAY NOT BE SHOWN OR NOTED.

CUSTOMER APPROVAL

NAME: _____

TITLE: _____

DATE: _____

REV.	DESCRIPTION	BY	DATE
C	AMERICAN FLAG DECAL ADDED TO FRONT GRILLE	RM	09/27/19
B	UPDATED ENGINE #S FOR HOSEBED FLAPS	RM	09/12/19
A	REV-A SHOP ORDER	RM	01/31/19

THIS PRINT IS PROVIDED ON A RESTRICTED BASIS AND IS NOT TO BE USED IN ANY WAY DETRIMENTAL TO THE INTEREST OF SUTPHEN CORPORATION.

DRAWN BY:
R. MILLER

DATE:
03/02/17

MFG. FACILITY:
DUBLIN

SUTPHEN

PALM BEACH COUNTY FIRE RESCUE
WEST PALM BEACH, FL

CUSTOM PUMPER - MODIFIED S4 BODY

DWG. NO.: HS-6394-96