

LEFT SIDE COMPARTMENTATION				
COMPT	DOORS	OPENING DIMENSIONS	INSIDE DIMENSIONS	VOLUME
L1	DOUBLE	24 3/4" w X 62 3/4" h	28 3/4" w X 66" h X 27 1/4" d	30 CU. FT.
L2	LIFT-UP	57 1/2" w X 32 1/4" h	61 1/2" w X 36 1/2" h X 27 1/4" d	30 CU. FT.
L3	DOUBLE	48 1/2" w X 62 3/4" h	53 1/2" w X 66" h X 27 1/4" d	55 CU. FT.

RIGHT SIDE COMPARTMENTATION				
COMPT	DOORS	OPENING DIMENSIONS	INSIDE DIMENSIONS	VOLUME
R1	DOUBLE	24 3/4" w X 62 3/4" h	28 3/4" w X 66" h X 27 1/4" d (10 1/2" d upper)	20 CU. FT.
R2	LIFT-UP	57 1/2" w X 32 1/4" h	61 1/2" w X 36 1/2" h X 10 1/2" d	13 CU. FT.
R3	DOUBLE	48 1/2" w X 62 3/4" h	53 1/2" w X 66" h X 27 1/4" d (10 1/2" d upper)	43 CU. FT.

REAR STEP COMPARTMENTS				
COMPT	DOORS	OPENING DIMENSIONS	INSIDE DIMENSIONS	VOLUME
A1	ROLL-UP	37 1/2" w X 37" h	46" h X 40" w X 30 1/2" d	33 CU. FT.

TOTAL: 224 CU. FT.

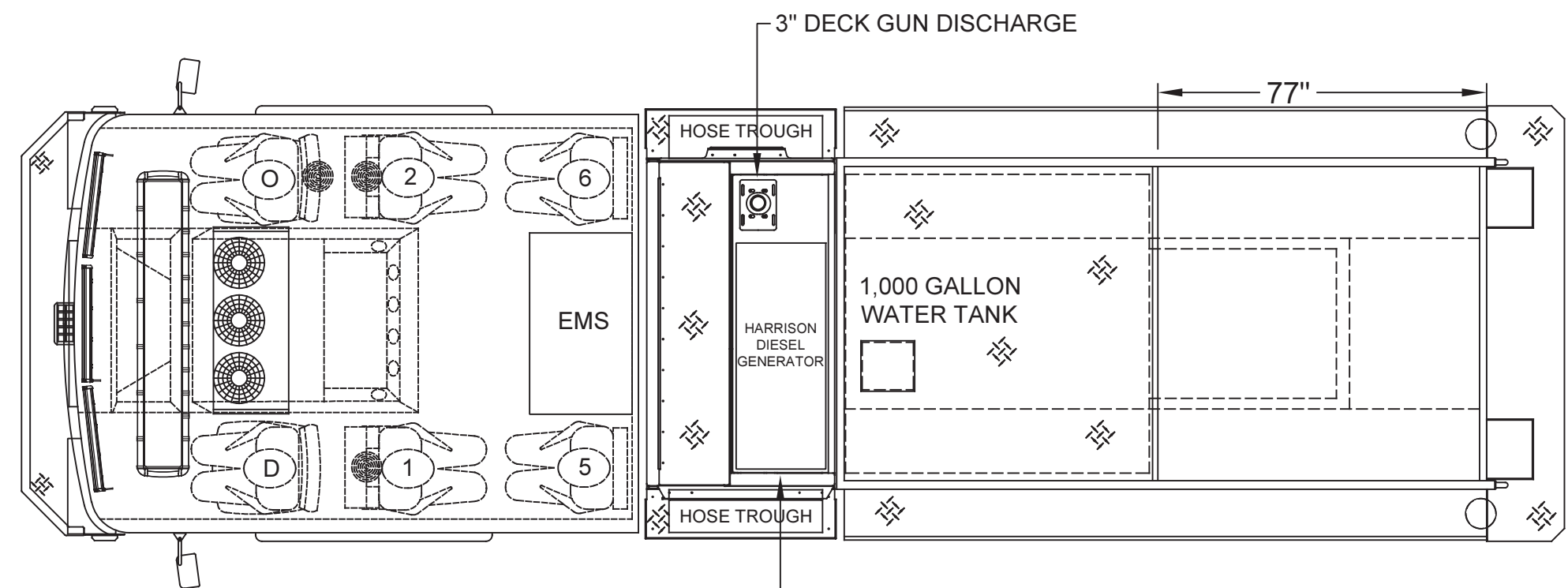

TWO-TONE CAB
PAINT BREAK OPTION #1
WHITE OVER RED

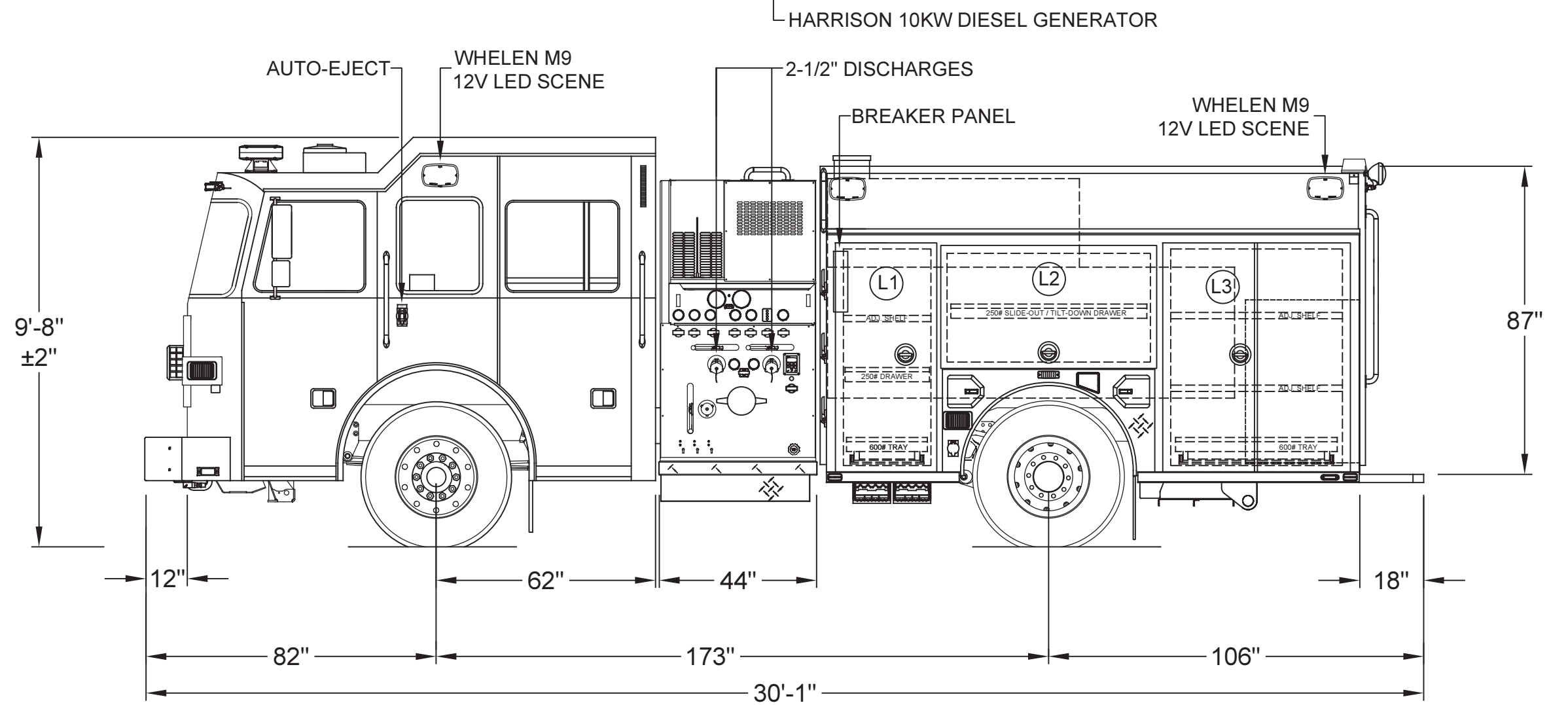
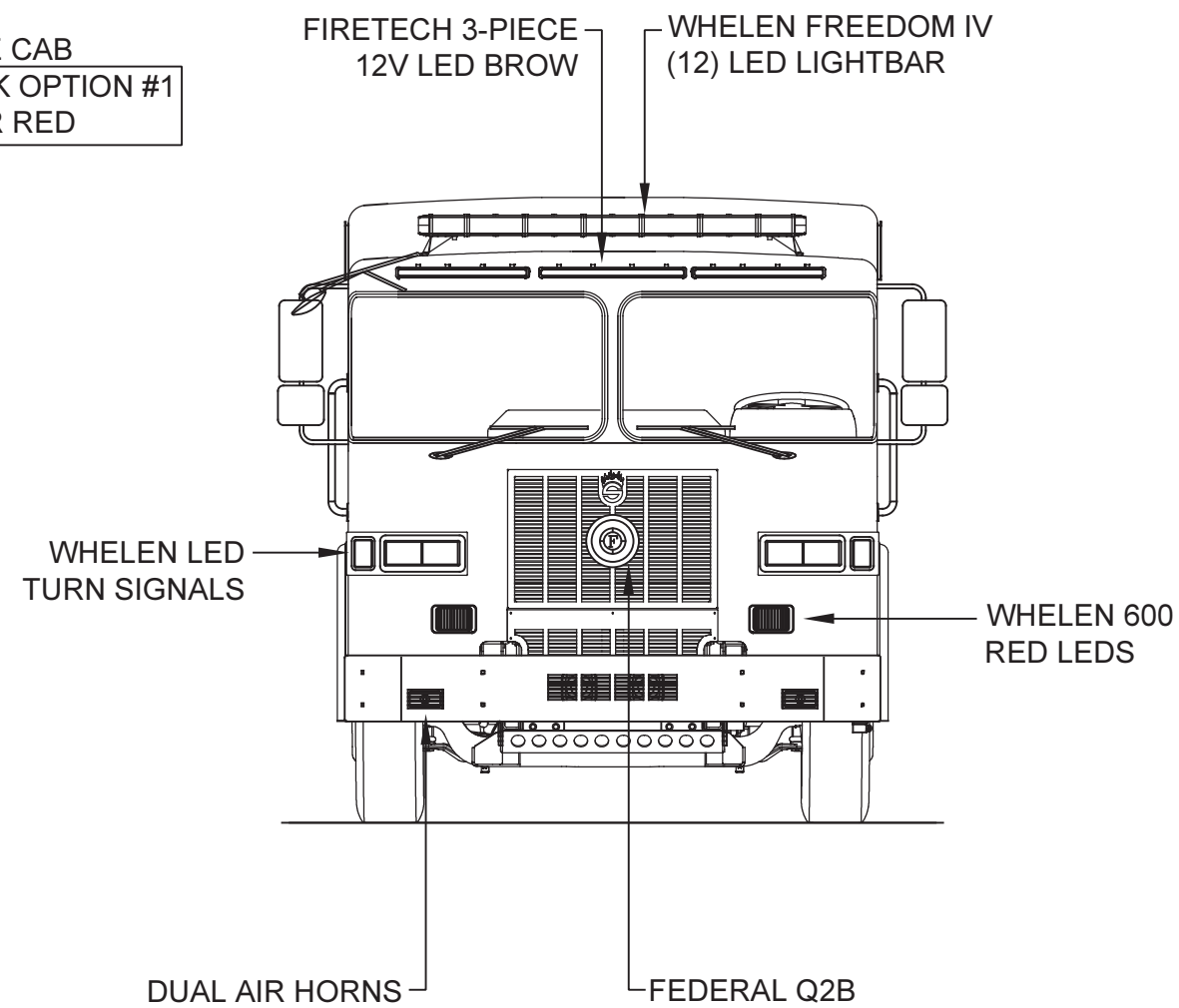

DIMENSIONS SHOWN ON THIS DRAWING ARE APPROXIMATE AND ARE SUBJECT TO MINOR DEVIATIONS DURING CONSTRUCTION.

IN THE EVENT OF A DISCREPANCY BETWEEN THE SUTPHEN SPECIFICATIONS AND DRAWING, THE SUTPHEN SPECIFICATIONS SHALL PREVAIL.

DRAWING IS FOR REFERENCE ONLY. SOME ITEMS PROPOSED MAY NOT BE SHOWN OR NOTED.

CUSTOMER APPROVAL

NAME: _____

TITLE: _____

DATE: _____

E	PSTANK GAUGES ADDED TO DWG ; WARNING LIGHT CALL-OUTS CORRECTED IN COMPONENT REPORT	RM	11/25/19
D	SEVERAL CLARIFICATIONS - SEE SO CHANGE SUMMARY ON SHARED OR SO REVISION EMAIL	RM	09/28/19
C	HOSEBED LENGTH CORRECTED TO 77" PER ENGINEERING MODEL OF PREVIOUS TRUCKS ; SEVERE CLIMATE AC	RM	07/22/19
B	(2) MINOR CHANGES - SEE SO REVISION EMAIL OR CHANGE SUMMARY ON SHARED	RM	05/23/19
REV.	DESCRIPTION	BY	DATE

THIS PRINT IS PROVIDED ON A RESTRICTED BASIS AND IS NOT TO BE USED IN ANY WAY DETRIMENTAL TO THE INTEREST OF SUTPHEN CORPORATION.

DRAWN BY:	R. MILLER
DATE:	12/19/17
MFG. FACILITY:	DUBLIN

SUTPHEN

DURHAM FIRE DEPARTMENT
DURHAM, NC

CUSTOM PUMPER - S2/S4 SPECIAL DURHAM BODY

DWG. NO.: HS-6390