

Hose Load
 1:250ft of 2.5" Preconnected
 2:500ft of 5"
 3:1000ft of 3"

Left Side Compartmentation				
Compt	Doors	Opening Dimensions	Inside Dimensions	Volume
			WxHxD	
L1	Hinged	33x55	40x60x24.25	31.8 CU FT
L2	Hinged	53x22	60x28x10.25	22.5 CU FT
L3	Hinged	48x55	55x60x24.25	43.7 CU FT
Right Side Compartmentation				
Compt	Doors	Opening Dimensions	Inside Dimensions	Volume
R1	Hinged	33x55	40x60x24.25/10.25	23.9 CU FT
R2	Hinged	53x22	60x28x10.25	10.7 CU FT
R2	Hinged	48x55	55x60x24.25/10.25	32.9 CU FT
Rear Compartmentation				
Compt	Doors	Opening Dimensions	Inside Dimensions	Volume
A1	Roll Up	41x20	48x30x24.25	20.2 CU FT
				Total Volume
				185.8 CU Ft

Waterous CSU-1500 Pump
Water Tank Capacity 1000 gal

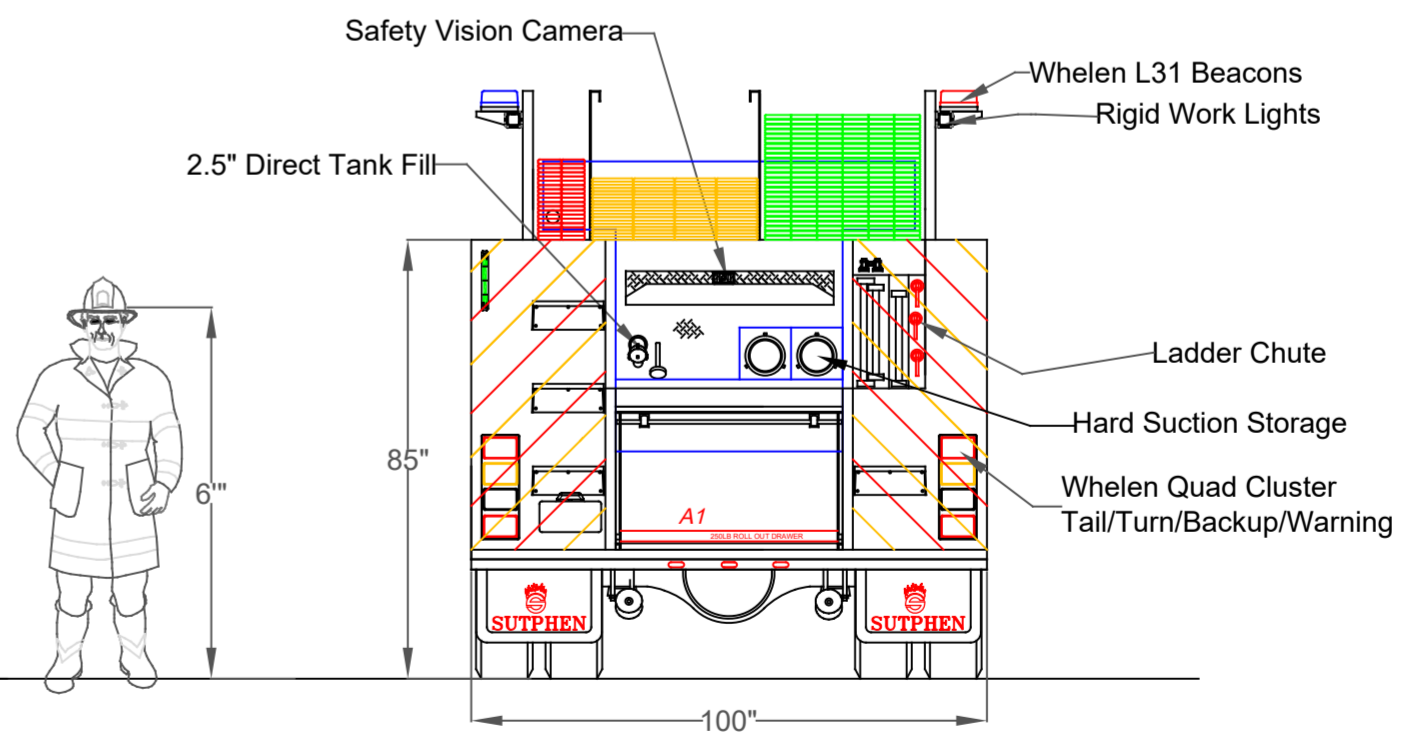
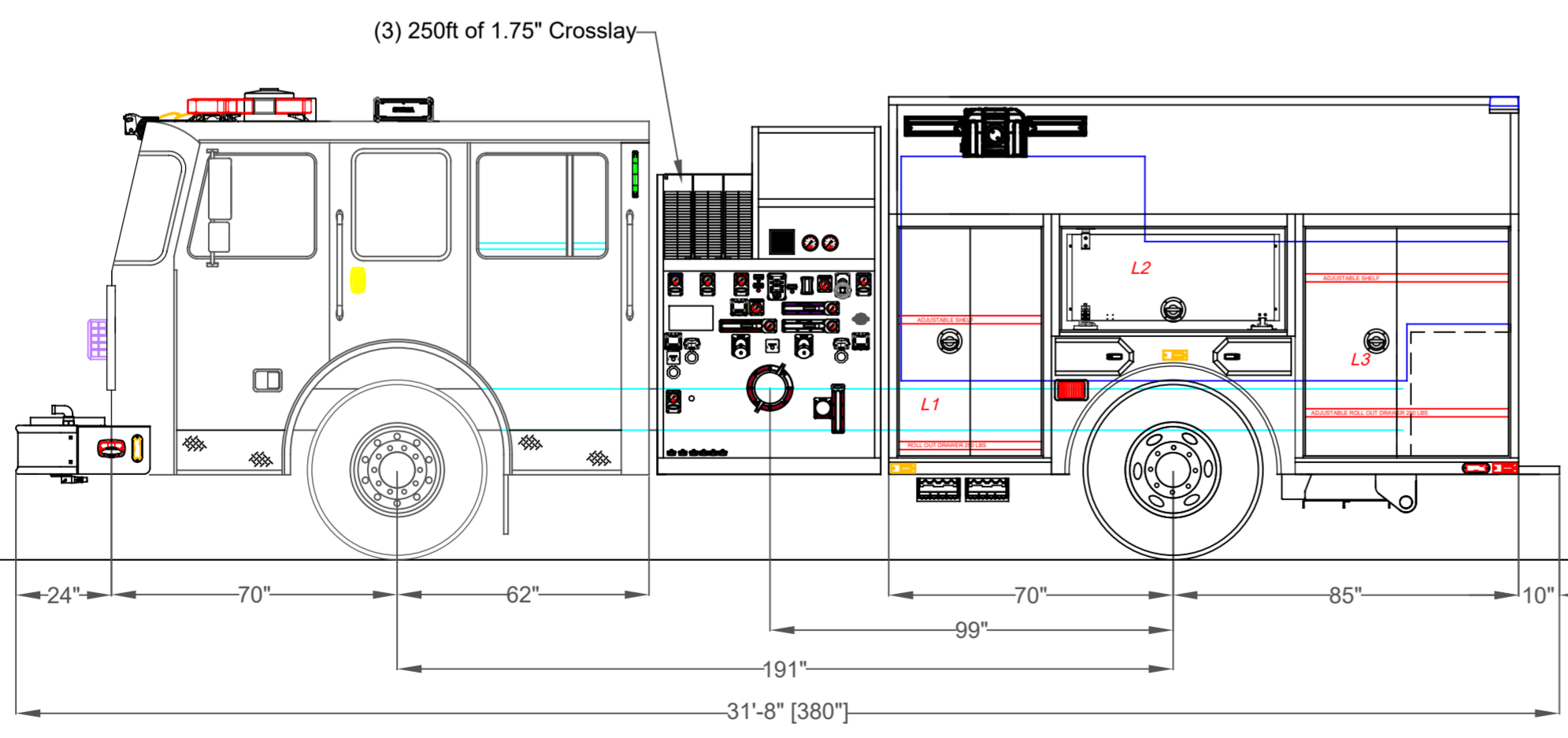

DIMENSIONS SHOWN ON THIS DRAWING ARE APPROXIMATE AND ARE SUBJECT TO MINOR DEVIATIONS DURING CONSTRUCTION. IN THE EVENT OF A DISCREPANCY BETWEEN THE SUTPHEN SPECIFICATIONS AND DRAWING, THE SUTPHEN SPECIFICATIONS SHALL PREVAIL. DRAWING IS FOR REFERENCE ONLY. SOME ITEMS PROPOSED MAY NOT BE SHOWN OR NOTED.	CUSTOMER APPROVAL NAME: _____ TITLE: _____ DATE: _____			DRAWN BY: J. Gordon	SUTPHEN EAST 55 INNOVATION DRIVE LAKE ARIEL, PA 1-844-776-2889 Jeffersonville Fire Dept. Jeffersonville, NY CUSTOM PUMPER S2/S4 BODY DWG. NO.: HS 6375
	REV. _____ DESCRIPTION _____ BY _____ DATE _____	DATE: 10/08/2018	MFG. FACILITY: SUTPHEN EAST LAKE ARIEL, PA		
THIS PRINT IS PROVIDED ON A RESTRICTED BASIS AND IS NOT TO BE USED IN ANY WAY DETRIMENTAL TO THE INTEREST OF SUTPHEN CORPORATION.					