

| LEFT SIDE COMPARTMENTS | | | | |
|------------------------|---------|--------------------|-----------------------------|--------------------------------------|
| COMPT | DOORS | OPENING DIMENSIONS | INSIDE DIMENSIONS | VOLUME |
| L1 | ROLL-UP | 37.5" w X 56.2" h | 43.1" w X 66" h X 27.3" d | 40.8 CU. FT. (10" h X 10.5" d UPPER) |
| L2 | ROLL-UP | 55.5" w X 27.0" h | 61.6" w X 36.8" h X 27.3" d | 29.8 CU. FT. (10" h X 10.5" d UPPER) |
| L3 | ROLL-UP | 43.5" w X 55.4" h | 46.4" w X 66" h X 27.3" d | 43.9 CU. FT. (10" h X 10.5" d UPPER) |

| RIGHT SIDE COMPARTMENTS | | | | |
|-------------------------|---------|--------------------|-----------------------------|--------------------------------------|
| COMPT | DOORS | OPENING DIMENSIONS | INSIDE DIMENSIONS | VOLUME |
| R1 | ROLL-UP | 37.5" w X 56.2" h | 43.1" w X 66" h X 27.3" d | 31.1 CU. FT. (33" h X 10.5" d UPPER) |
| R2 | ROLL-UP | 55.5" w X 27.0" h | 61.6" w X 36.8" h X 27.3" d | 13.8 CU. FT. (33" h X 10.5" d UPPER) |
| R3 | ROLL-UP | 43.5" w X 55.4" h | 46.4" w X 66" h X 27.3" d | 33.5 CU. FT. (33" h X 10.5" d UPPER) |

| REAR STEP COMPARTMENT | | | | |
|-----------------------|--------|--------------------|-----------------------|--------------|
| COMPT | DOORS | OPENING DIMENSIONS | INSIDE DIMENSIONS | VOLUME |
| A1 | DOUBLE | 37" w X 32.1" h | 40" h X 40" w X 26" d | 24.1 CU. FT. |

TOTAL: 217.0 CU.FT.

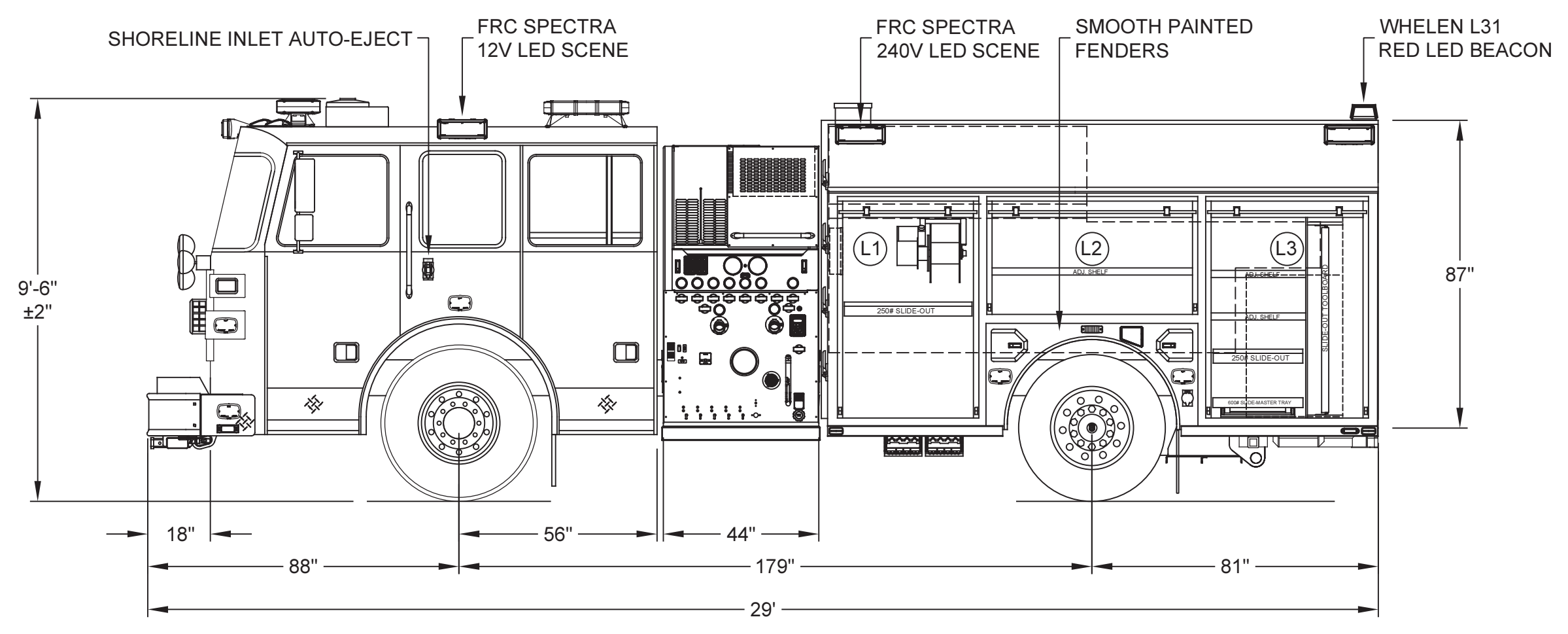
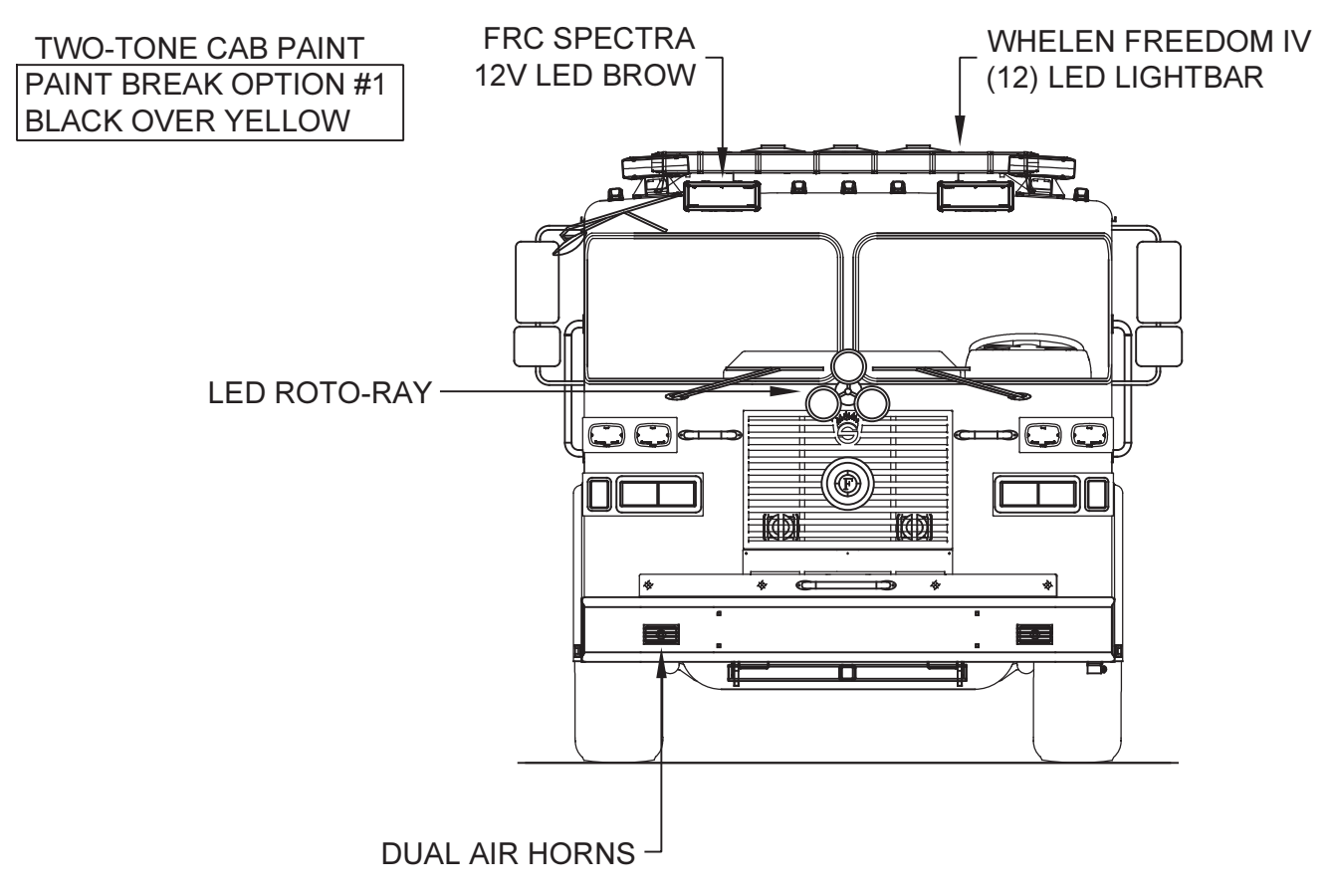
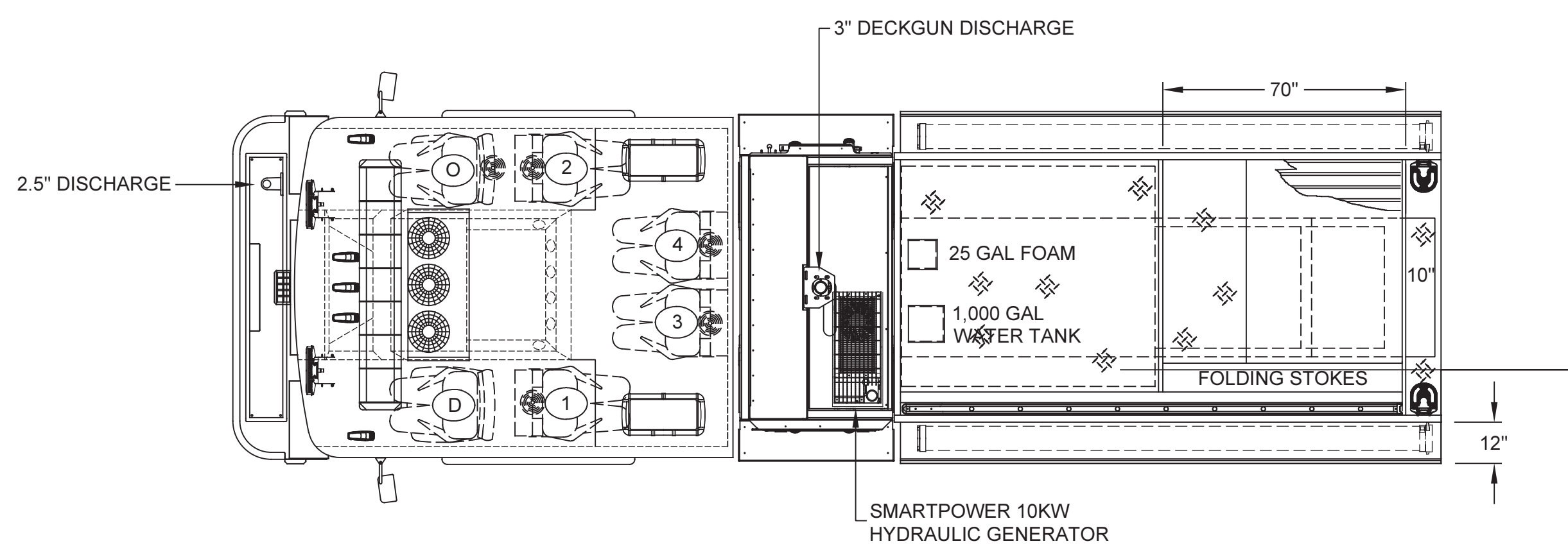

DIMENSIONS SHOWN ON THIS DRAWING ARE APPROXIMATE AND ARE SUBJECT TO MINOR DEVIATIONS DURING CONSTRUCTION.

IN THE EVENT OF A DISCREPANCY BETWEEN THE SUTPHEN SPECIFICATIONS AND DRAWING, THE SUTPHEN SPECIFICATIONS SHALL PREVAIL.

DRAWING IS FOR REFERENCE ONLY. SOME ITEMS PROPOSED MAY NOT BE SHOWN OR NOTED.

CUSTOMER APPROVAL

NAME: _____

TITLE: _____

DATE: _____

| | | | |
|------|---|----|----------|
| J | L3 SHELVING MODIFICATIONS DUE TO NOTCH | RM | 12/11/19 |
| I | UPDATES TO SHELVING | RM | 12/03/19 |
| H | HARD SUCTION HOSE TO BE REORDERED AT 12' SECTIONS | RM | 11/21/19 |
| G | MINOR CLARIFICATIONS - SEE SO CHANGE SUMMARY ON SHARED OR SO REVISION EMAIL | RM | 11/11/19 |
| REV. | DESCRIPTION | BY | DATE |

THIS PRINT IS PROVIDED ON A RESTRICTED BASIS AND IS NOT TO BE USED IN ANY WAY DETRIMENTAL TO THE INTEREST OF SUTPHEN CORPORATION.

DRAWN BY:
R. MILLER

DATE:
01/22/19

MFG. FACILITY:
DUBLIN

SUTPHEN

FORT VALLEY FIRE DEPARTMENT
FORT VALLEY, VA

CUSTOM PUMPER - MODIFIED PA-12 BODY

DWG. NO.: HS-6374