

HOSEBED
 (2) 10' SECT. HARD SUCT
 300' OF 1.75"
 1,300' OF 5"
 400' OF 3"
 300' OF 2.5"
 BBOARD / (3) PIKE COMPT

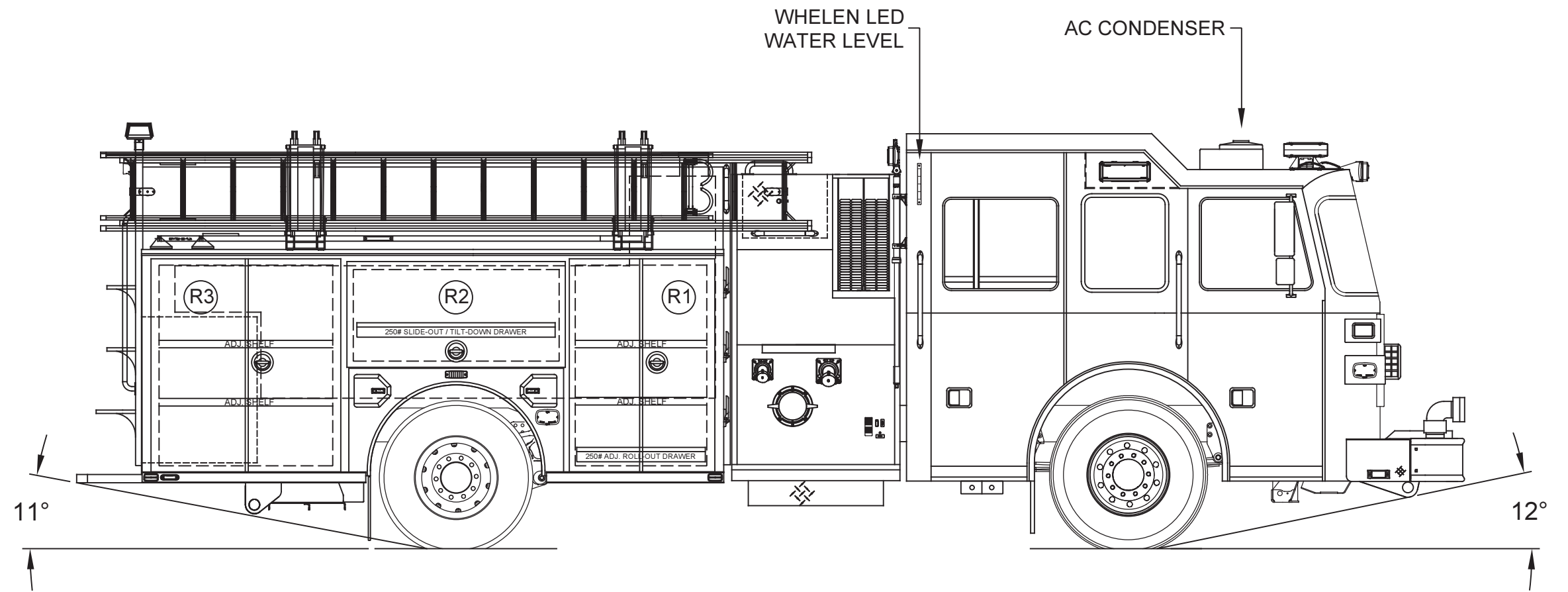
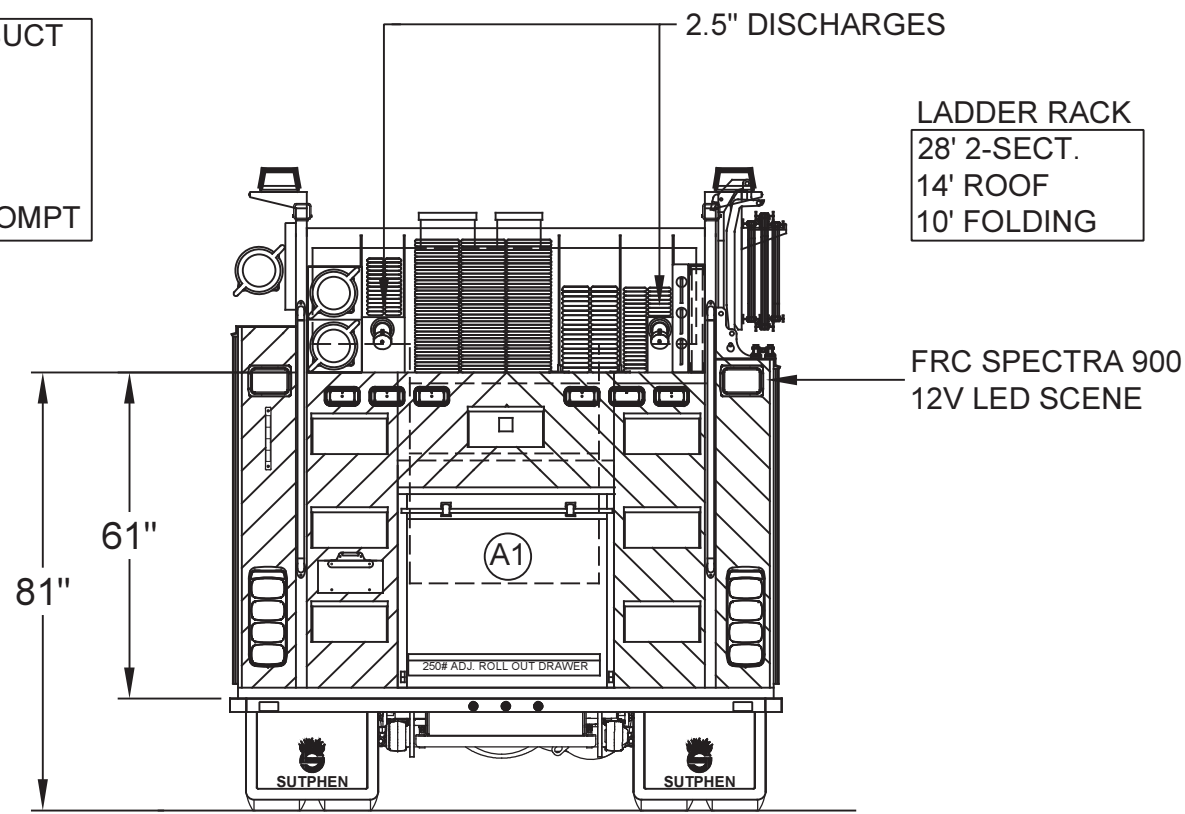

| LEFT SIDE COMPARTMENTS | | | | |
|------------------------|---------|--------------------|-----------------------------|--------------------------------------|
| COMPT | DOORS | OPENING DIMENSIONS | INSIDE DIMENSIONS | VOLUME |
| L1 | DOUBLE | 33.5" w X 57.7" h | 43.1" w X 66" h X 27.3" d | 40.8 CU. FT. (10" h X 10.5" d UPPER) |
| L2 | LIFT-UP | 53.0" w X 31.3" h | 61.6" w X 36.8" h X 27.3" d | 29.8 CU. FT. (10" h X 10.5" d UPPER) |
| L3 | DOUBLE | 46.5" w X 57.7" h | 52.4" w X 66" h X 27.3" d | 49.6 CU. FT. (10" h X 10.5" d UPPER) |

| RIGHT SIDE COMPARTMENTS | | | | |
|-------------------------|---------|--------------------|-----------------------------|-------------------------------------|
| COMPT | DOORS | OPENING DIMENSIONS | INSIDE DIMENSIONS | VOLUME |
| R1 | DOUBLE | 33.5" w X 57.7" h | 43.1" w X 60" h X 27.3" d | 39.2 CU. FT. (4" h X 10.5" d UPPER) |
| R2 | LIFT-UP | 53.0" w X 31.3" h | 61.6" w X 30.8" h X 27.3" d | 27.6 CU. FT. (4" h X 10.5" d UPPER) |
| R3 | DOUBLE | 46.5" w X 57.7" h | 52.4" w X 60" h X 27.3" d | 47.6 CU. FT. (4" h X 10.5" d UPPER) |

| REAR STEP COMPARTMENT | | | | |
|-----------------------|---------|--------------------|-----------------------|--------------|
| COMPT | DOORS | OPENING DIMENSIONS | INSIDE DIMENSIONS | VOLUME |
| A1 | ROLL-UP | 37" w X 32.1" h | 40" h X 40" w X 31" d | 28.7 CU. FT. |

TOTAL: 263.3 CU.FT.

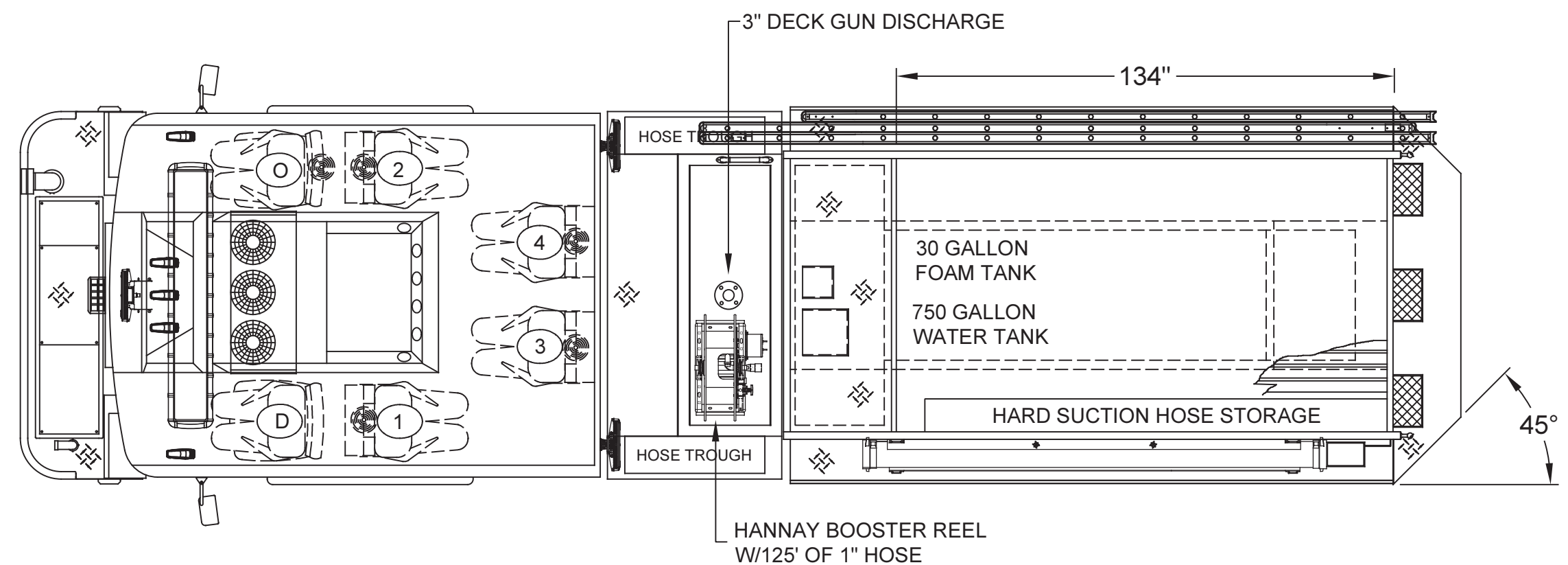

TWO-TONE CAB
 PAINT BREAK OPTION #3
 GRAY OVER RED

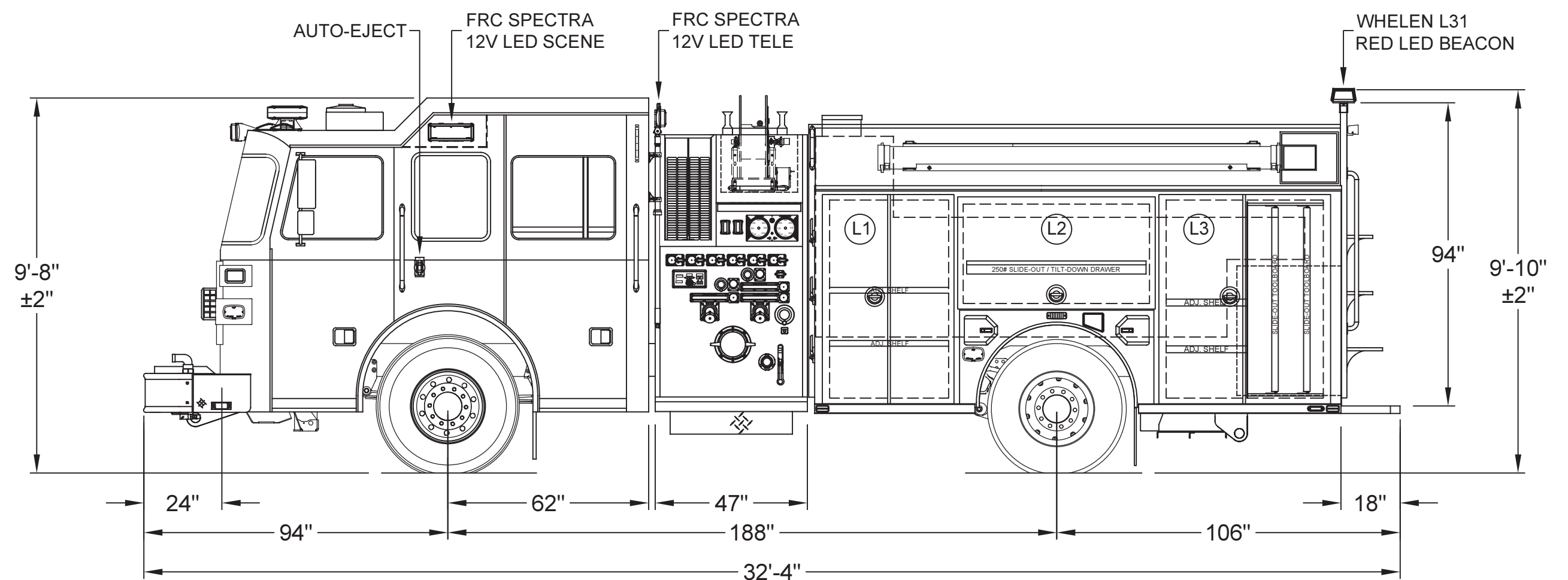
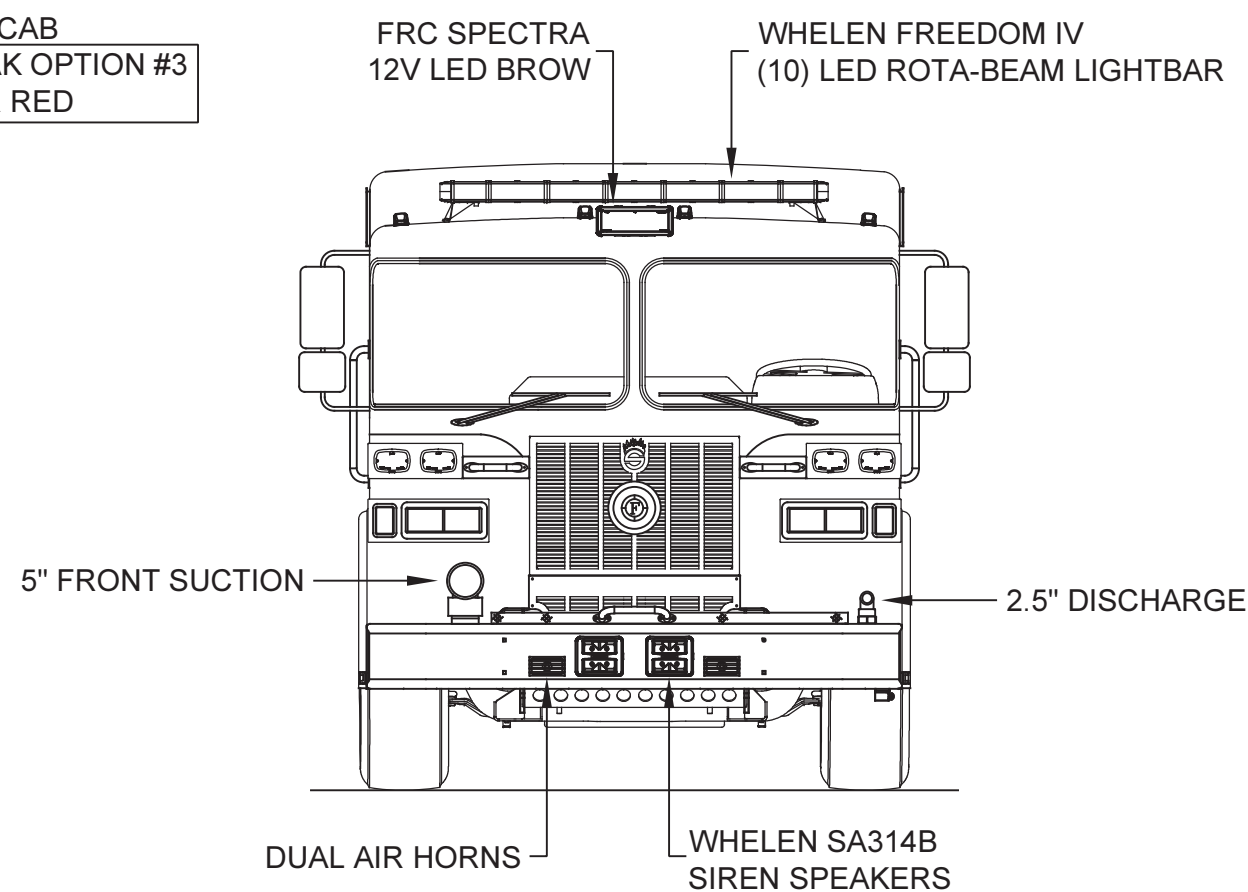

DIMENSIONS SHOWN ON THIS DRAWING ARE APPROXIMATE AND ARE SUBJECT TO MINOR DEVIATIONS DURING CONSTRUCTION.

CUSTOMER APPROVAL

NAME: _____
 TITLE: _____
 DATE: _____

| | | | |
|------|--|----|----------|
| G | SPECTRA900 LIGHTS ON REAR OF BODY MOVED TO SAME HEIGHT | RM | 10/21/19 |
| F | MINOR CLARIFICATIONS | RM | 09/09/19 |
| E | SEVERAL UPDATES - SEE SO CHANGE SUMMARY ON SHARED OR COMPONENT REPORT ATTACHED | RM | 08/13/19 |
| D | BOOSTER REEL ADDED TO DRIVER'S SIDE DUNNAGE AREA | RM | 05/24/19 |
| REV. | DESCRIPTION | BY | DATE |

DRAWN BY:
 R.MILLER

DATE:
 10/11/18

MFG. FACILITY:
 DUBLIN

SUTPHEN

POWHATAN COUNTY FIRE RESCUE
 POWHATAN, VA

CUSTOM PUMPER - PA-12 BODY
 DWG. NO.: HS-6362