

Left Side Compartmentation				
Compt	Doors	Opening Dimensions	Inside Dimensions	Volume
L1	Roll Up	49x62	56x72x12.25/27.25	48 CU FT
L2	Roll Up	50.5x22	57.5x32x12.25	13 CU FT
L3	Roll Up	50.5x22	57.5x32x12.25	13 CU FT
L4	Roll Up	46x62	53x72x12.25/27.25	45.5 CU FT
Right Side Compartmentation				
Compt	Doors	Opening Dimensions	Inside Dimensions	Volume
R1	Roll Up	49x62	56x72x12.25/27.25	48 CU FT
R2	Roll Up	50.5x22	57.5x32x12.25	13 CU FT
R3	Roll Up	50.5x22	57.5x32x12.25	13 CU FT
R4	Roll Up	46x62	53x72x12.25/27.25	45.5 CU FT
Total Volume				239 CU Ft

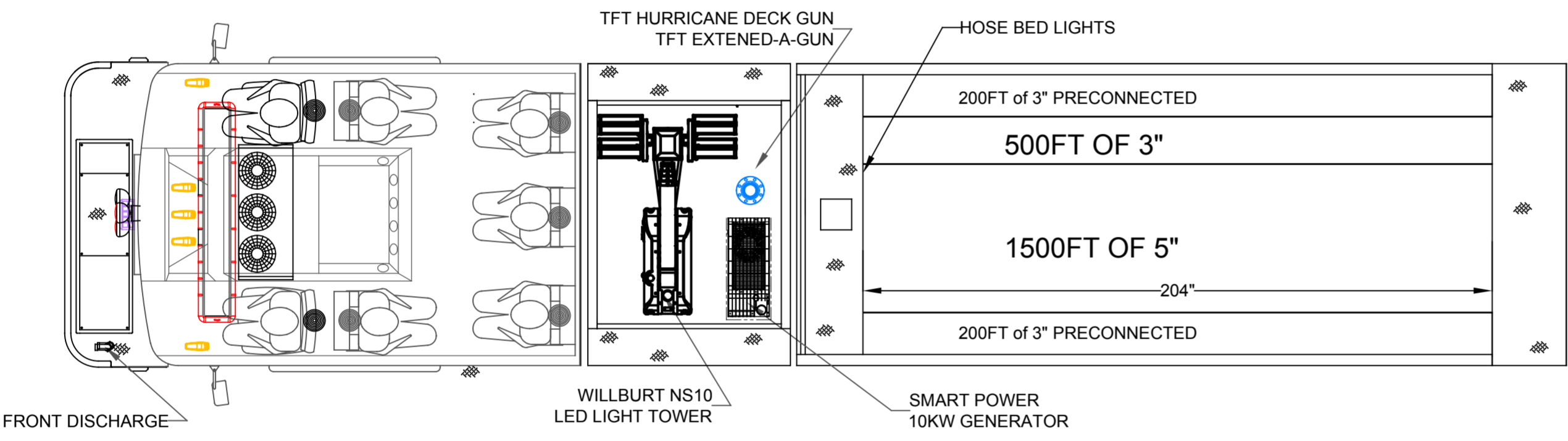

**PUMP:HALE QMAX 1500 GPM**  
**TANK:2500 GALLONS WATER**  
**FOAM:N/A**

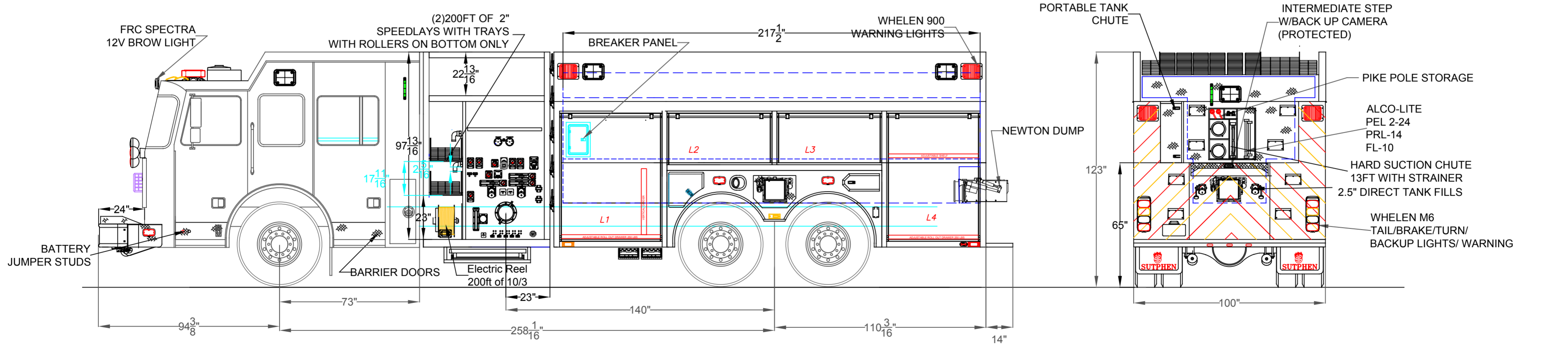

DIMENSIONS SHOWN ON THIS DRAWING ARE APPROXIMATE AND ARE SUBJECT TO MINOR DEVIATIONS DURING CONSTRUCTION.	CUSTOMER APPROVAL						DRAWN BY: S. DORFMAN	SUTPHEN EAST 55 INNOVATION DRIVE LAKE ARIEL, PA 1-844-776-2889
	NAME:		D	CHANGE REAR CHEVRON LAYOUT	SED	6/12/19	DATE: 7/19/17	
IN THE EVENT OF A DISCREPANCY BETWEEN THE SUTPHEN SPECIFICATIONS AND DRAWING, THE SUTPHEN SPECIFICATIONS SHALL PREVAIL.	TITLE:		C	CHANGES FROM REV C	SED	4/1/19	MFG. FACILITY: SUTPHEN EAST LAKE ARIEL, PA	PERKIOMEN FC COLLEGEVILLE PA 19426
DRAWING IS FOR REFERENCE ONLY. SOME ITEMS PROPOSED MAY NOT BE SHOWN OR NOTED.	DATE:		A	CHANGES FROM PRE-CON	SED	9/20/18	DWG. NO.:	ALUMINUM PUMPER/TANKER HS 6346
THIS PRINT IS PROVIDED ON A RESTRICTED BASIS AND IS NOT TO BE USED IN ANY WAY DETRIMENTAL TO THE INTEREST OF SUTPHEN CORPORATION.								