

Left Side Compartmentation				
Compt	Doors	Opening Dimensions	Inside Dimensions	Volume
WxHxD				
L1	Roll Up	23x62	30x72x27.25/12.25	25.9 CU FT
L2	Roll Up	57x28	64x38x12.25	16.4 CU FT
L3	Roll Up	48x62	55x72x27.25/12.5 (Transverse)	47.6 CU FT
Right Side Compartmentation				
Compt	Doors	Opening Dimensions	Inside Dimensions	Volume
R1	Roll Up	23x23	30x33x27.25	15.6 CU FT
R2	Roll Up	48x23	55x33x27.25 (Transverse)	28.6 CU FT
Rear Compartmentation				
Compt	Doors	Opening Dimensions	Inside Dimensions	Volume
A1	Roll Up	35x29	42x43x29.25	30.6 CU FT
Total Volume				164.7 CU FT

Hale DSD 1500 single stage  
Water Tank Capacity 750 gal

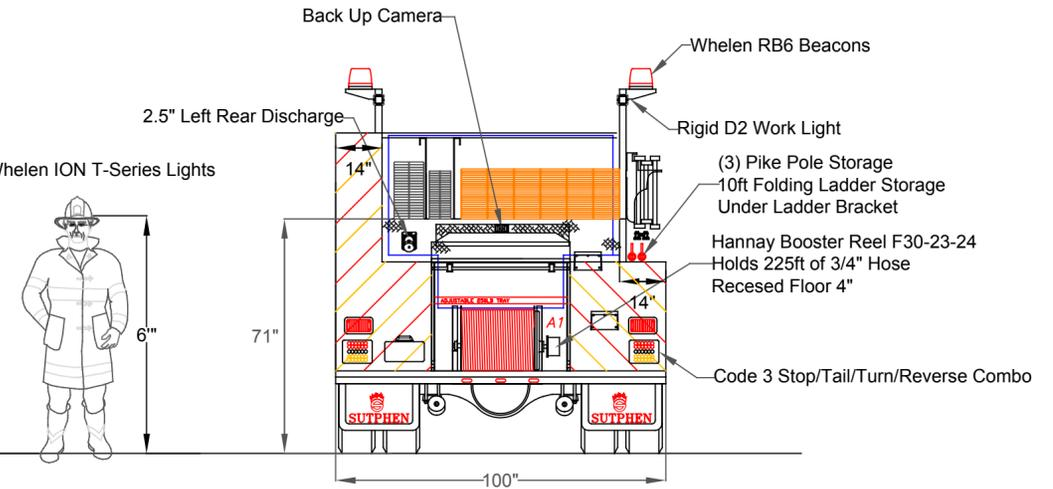
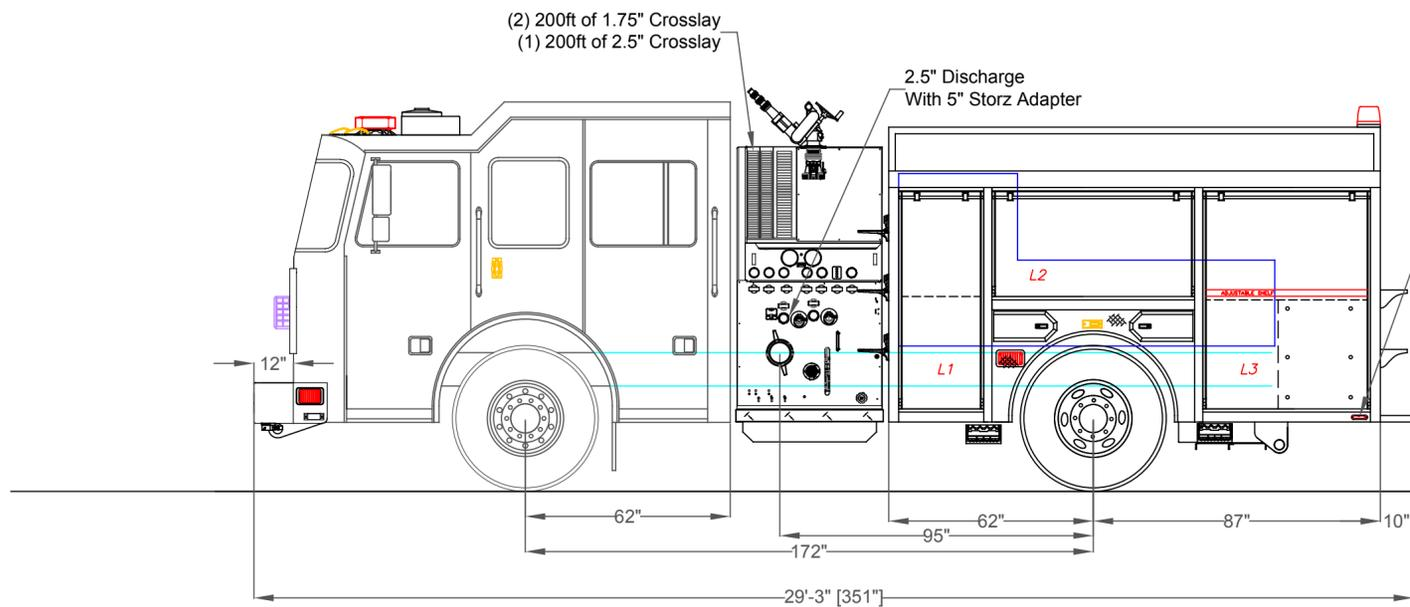

DIMENSIONS SHOWN ON THIS DRAWING ARE APPROXIMATE AND ARE SUBJECT TO MINOR DEVIATIONS DURING CONSTRUCTION.

IN THE EVENT OF A DISCREPANCY BETWEEN THE SUTPHEN SPECIFICATIONS AND DRAWING, THE SUTPHEN SPECIFICATIONS SHALL PREVAIL.

DRAWING IS FOR REFERENCE ONLY. SOME ITEMS PROPOSED MAY NOT BE SHOWN OR NOTED.

**CUSTOMER APPROVAL**

NAME: \_\_\_\_\_

TITLE: \_\_\_\_\_

DATE: \_\_\_\_\_

REV.	DESCRIPTION	BY	DATE
A	CHANGES FROM PRE-CON	SED	4/9/2018

THIS PRINT IS PROVIDED ON A RESTRICTED BASIS AND IS NOT TO BE USED IN ANY WAY DETRIMENTAL TO THE INTEREST OF SUTPHEN CORPORATION.

DRAWN BY: S. DORFMAN

DATE: 3/12/2018

MFG. FACILITY: SUTPHEN EAST LAKE ARIEL, PA

DWG. NO.: HS 6276

SUTPHEN EAST  
55 INNOVATION DRIVE  
LAKE ARIEL, PA  
1-844-776-2889

City of Scranton Fire Dept.  
Scranton, PA

Custom Aluminum Engine (PROGRAM 2-S1 BODY)