

Left Side Compartmentation				
Compt	Doors	Opening Dimensions	Inside Dimensions	Volume
			WxHxD	
L1	Roll Up	43x26	50x36x24.25	25.3 CU FT
L1	Roll Up	23x26	30x36x24.25	15.2 CU FT
Right Side Compartmentation				
Compt	Doors	Opening Dimensions	Inside Dimensions	Volume
R1	Roll Up	59x26	66x36x24.25	33.3 CU FT
R2	Roll Up	43x26	50x36x24.25	25.3 CU FT
R3	Roll Up	23x26	30x36x24.25	15.2 CU FT

Hale DSD 1250 Side Kick  
Water Tank Capacity 3500 gal

Total Volume	114.2 CU FT
--------------	-------------

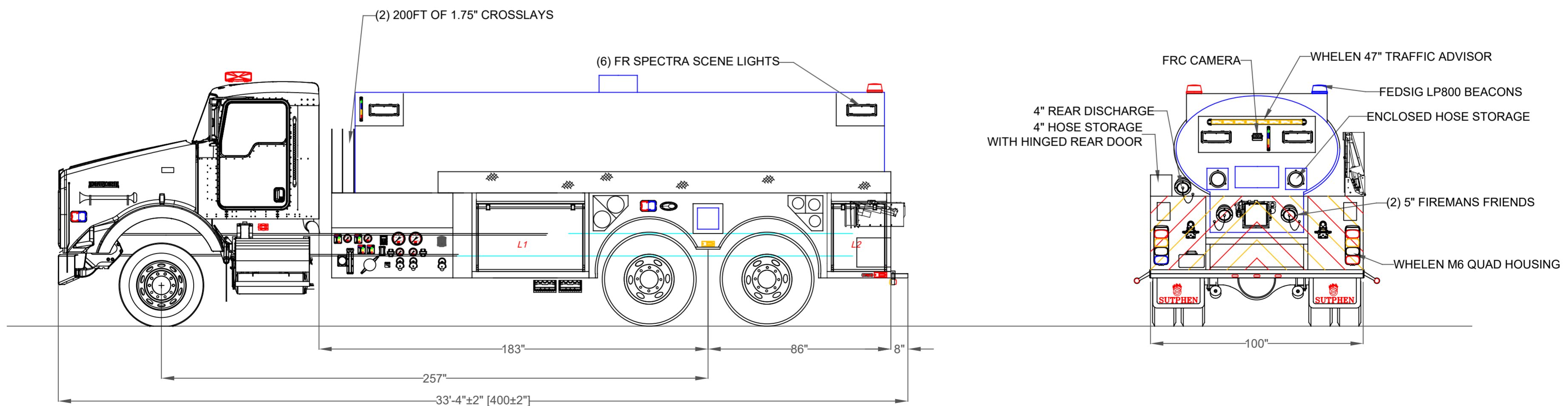

DIMENSIONS SHOWN ON THIS DRAWING ARE APPROXIMATE AND ARE SUBJECT TO MINOR DEVIATIONS DURING CONSTRUCTION.	CUSTOMER APPROVAL				DRAWN BY: J. Gordon	DATE: 06/28/2019	MFG. FACILITY: SUTPHEN EAST LAKE ARIEL, PA	SUTPHEN EAST 55 INNOVATION DRIVE LAKE ARIEL, PA 1-844-776-2889
	NAME: _____	_____	_____	_____				
IN THE EVENT OF A DISCREPANCY BETWEEN THE SUTPHEN SPECIFICATIONS AND DRAWING, THE SUTPHEN SPECIFICATIONS SHALL PREVAIL.	TITLE: _____	_____	_____	_____	Commercial Elliptical Tanker			
DRAWING IS FOR REFERENCE ONLY. SOME ITEMS PROPOSED MAY NOT BE SHOWN OR NOTED.	DATE: _____	REV. _____	DESCRIPTION _____	BY _____		DATE _____	DWG. NO.: HS 6594	

THIS PRINT IS PROVIDED ON A RESTRICTED BASIS AND IS NOT TO BE USED IN ANY WAY DETRIMENTAL TO THE INTEREST OF SUTPHEN CORPORATION.