

LEFT SIDE COMPARTMENTATION			
COMPT	DOORS	DIMENSIONS	VOLUME
L1	ROLL-UP	40"W X 51 1/2"H X 26"D	28 CU. FT.
L2	ROLL-UP	59"W X 21 1/2"H X 14 1/2"D	11 CU. FT.
L3	ROLL-UP	51 1/2"W X 51 1/2"H X 26"D	40 CU. FT.

14 1/2" DEEP, UPPER
FULL HEIGHT, FULL DEPTH

RIGHT SIDE COMPARTMENTATION			
COMPT	DOORS	DIMENSIONS	VOLUME
R1	ROLL-UP	40"W X 51 1/2"H X 26"D	28 CU. FT.
R2	ROLL-UP	59"W X 21 1/2"H X 14 1/2"D	11 CU. FT.
R3	ROLL-UP	51 1/2"W X 51 1/2"H X 26"D	40 CU. FT.

14 1/2" DEEP, UPPER
FULL HEIGHT, FULL DEPTH

REAR STEP COMPARTMENT			
COMPT	DOORS	DIMENSIONS	VOLUME
A1	ROLL-UP	39 1/2"W X 39"H X 31"D	27 CU. FT.

REAR CREW SEAT COMPARTMENT			
COMPT	DOORS	DIMENSIONS	VOLUME
C1	HINGED	47"W X 15"H X 18 1/2"D	8 CU. FT.

TOTAL STORAGE: 193 CU. FT.

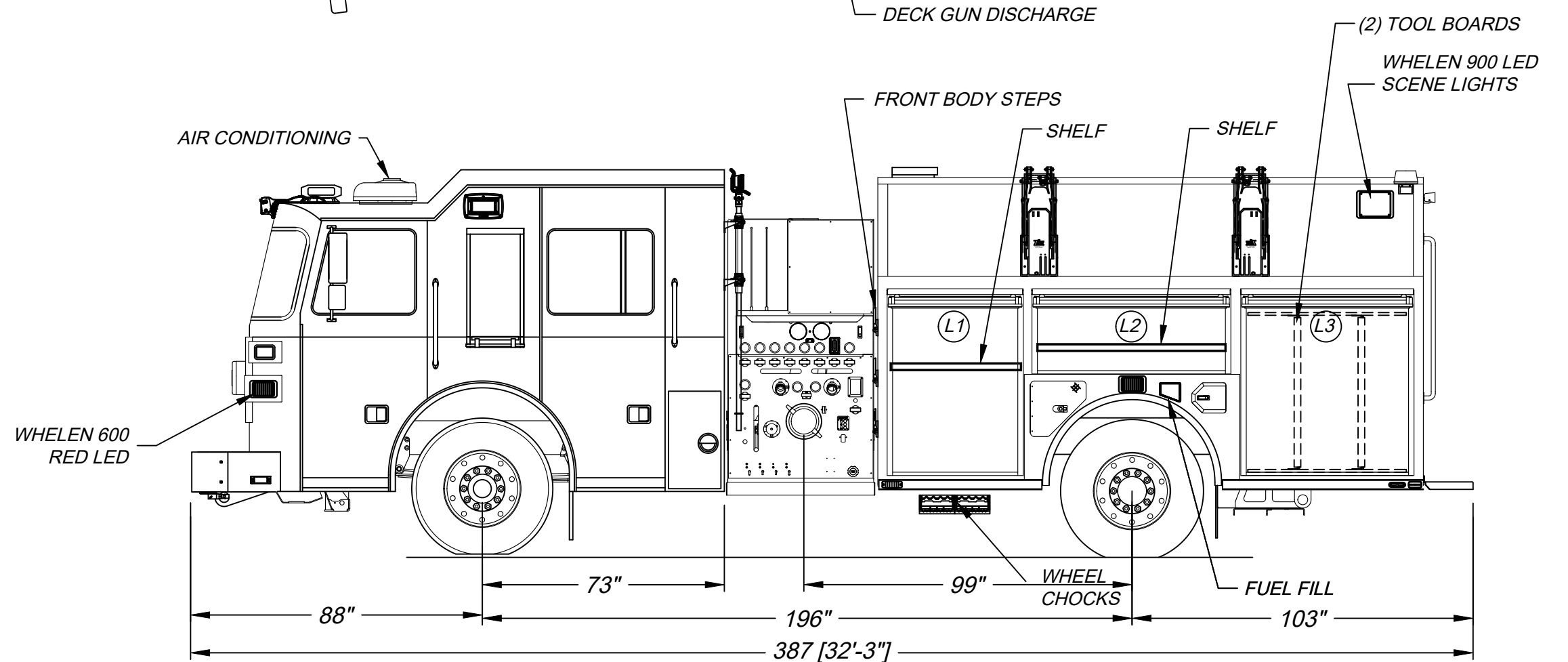
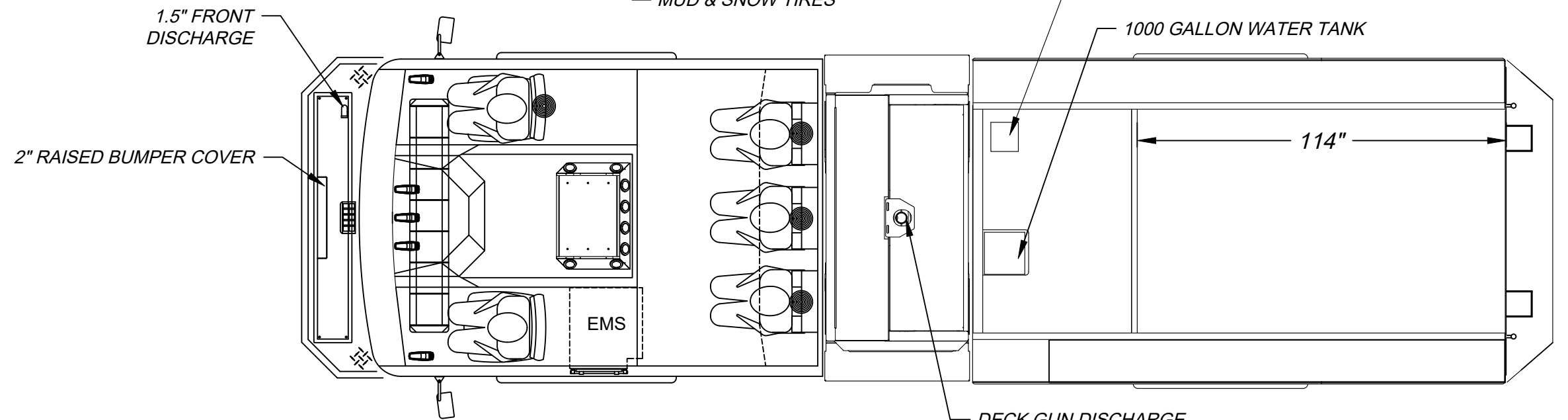
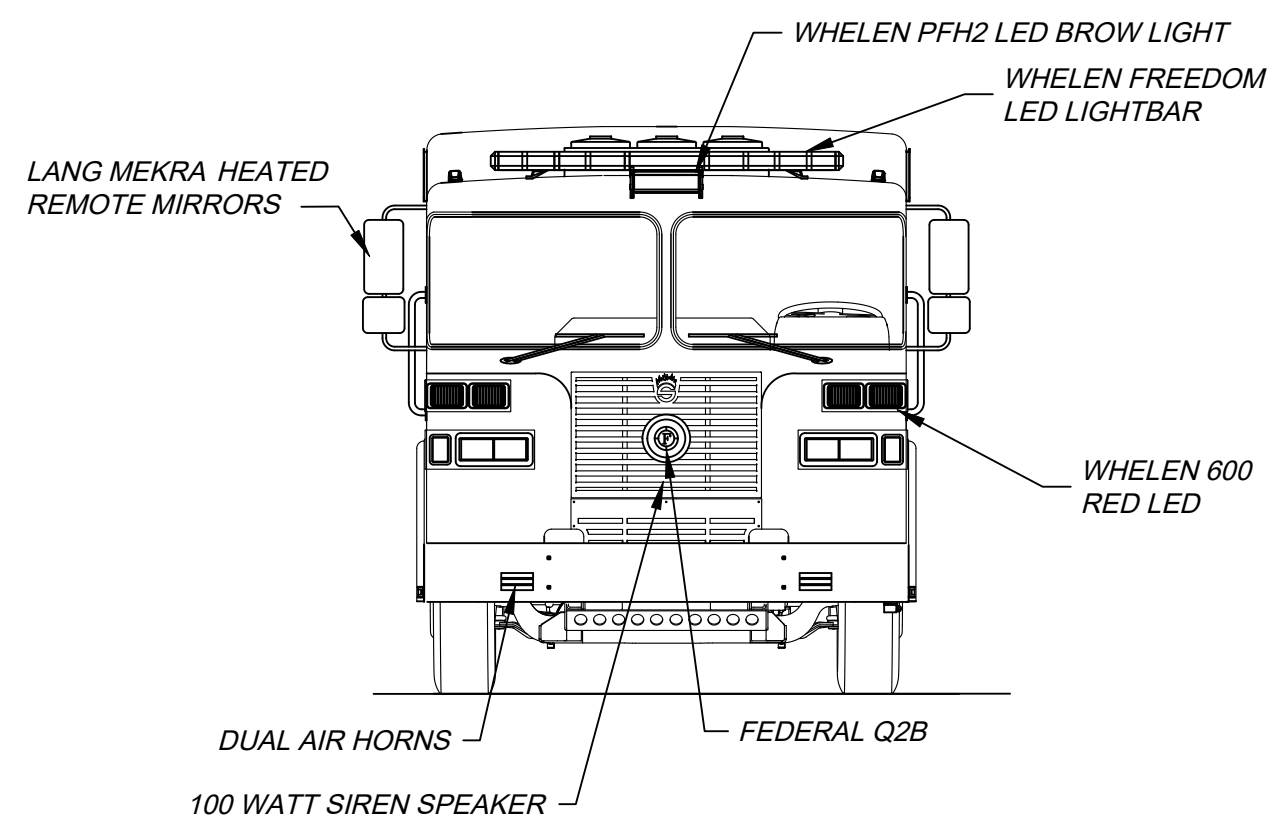

DIMENSIONS SHOWN ON THIS DRAWING ARE APPROXIMATE AND ARE SUBJECT TO MINOR DEVIATIONS DURING CONSTRUCTION.

IN THE EVENT OF A DISCREPANCY BETWEEN THE SUTPHEN SPECIFICATIONS AND DRAWING, THE SUTPHEN SPECIFICATIONS SHALL PREVAIL.

DRAWING IS FOR REFERENCE ONLY. SOME ITEMS PROPOSED MAY NOT BE SHOWN OR NOTED.

CUSTOMER APPROVAL

NAME: _____

TITLE: _____

DATE: _____

REV.	DESCRIPTION	BY	DATE

DRAWN BY:
J. HAULMAN

DATE:
3/16/2020

MFG. FACILITY:
URBANA

DANVILLE FIRE DEPARTMENT
DANVILLE, NH.

PROGRAM 1 CUSTOM PUMPER, G7 BODY

DWG. NO.: HS-6688