

**Hose Load**  
 1:250ft of 2.5" Preconnected  
 2:500ft of 2.5"  
 3:1300ft of 4"

Left Side Compartmentation				
Compt	Doors	Opening Dimensions	Inside Dimensions	Volume
			WxHxD	
L1	Roll Up	38x38	45x48x24.25/10.25	26.3 CU FT
L2	Drop Down	52x8	56x11x10.25	3.7 CU FT
L3	Drop Down	52x8	56x11x10.25	3.7 CU FT
L4	Roll Up	38x38	45x48x24.25/10.25	26.3 CU FT
Right Side Compartmentation				
Compt	Doors	Opening Dimensions	Inside Dimensions	Volume
R1	Roll Up	38x38	45x48x24.25/10.25	26.3 CU FT
R2	Drop Down	52x8	56x11x10.25	3.7 CU FT
R3	Drop Down	52x8	56x11x10.25	3.7 CU FT
R4	Roll Up	38x38	45x48x24.25/10.25	26.3 CU FT
Rear Compartmentation				
Compt	Doors	Opening Dimensions	Inside Dimensions	Volume
A1	Drop Down	47.5x15	48x17x15.25	7.2 CU FT
				<b>Total Volume</b>
				127.0 CU FT

**Hale Qmax 1500 single stage**  
**Water Tank Capacity 2500 gal**  
**Foam Tank Capacity 30 gal**

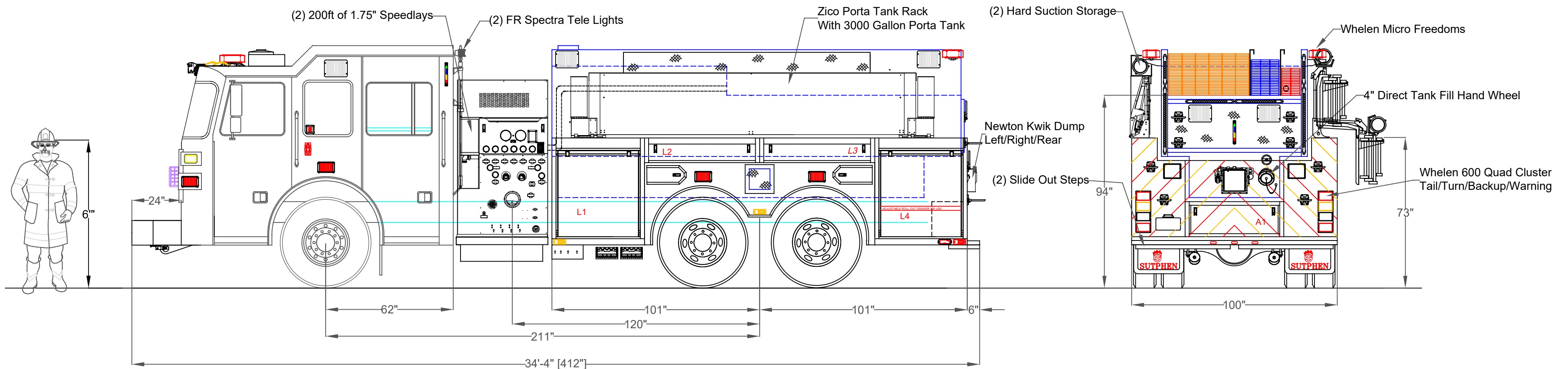

DIMENSIONS SHOWN ON THIS DRAWING ARE APPROXIMATE AND ARE SUBJECT TO MINOR DEVIATIONS DURING CONSTRUCTION.	CUSTOMER APPROVAL				DRAWN BY: J. Gordon	DATE: 1/02/2018	MFG. FACILITY: SUTPHEN EAST LAKE ARIEL, PA	DWG. NO.:
	NAME:							
IN THE EVENT OF A DISCREPANCY BETWEEN THE SUTPHEN SPECIFICATIONS AND DRAWING, THE SUTPHEN SPECIFICATIONS SHALL PREVAIL.	TITLE:							Cochran Volunteer Fire Dept. Cochran, PA
DRAWING IS FOR REFERENCE ONLY. SOME ITEMS PROPOSED MAY NOT BE SHOWN OR NOTED.	DATE:							Custom Wetside Tanker SALES DRAWING
REV. DESCRIPTION					BY	DATE		
THIS PRINT IS PROVIDED ON A RESTRICTED BASIS AND IS NOT TO BE USED IN ANY WAY DETRIMENTAL TO THE INTEREST OF SUTPHEN CORPORATION.								