

LEFT SIDE COMPARTMENTS				
COMPT	DOORS	OPENING DIMENSIONS	INSIDE DIMENSIONS	VOLUME
L1	ROLL-UP	37.5" w X 55.4" h	43.1" w X 66" h X 25.8" d	38.7 CU. FT. (10" h X 10.5" d UPPER)
L2	ROLL-UP	57.5" w X 26.2" h	61.6" w X 36.8" h X 25.8" d	28.4 CU. FT. (10" h X 10.5" d UPPER)
L3	ROLL-UP	50.5" w X 55.4" h	53.4" w X 66" h X 25.8" d	47.9 CU. FT. (10" h X 10.5" d UPPER)
RIGHT SIDE COMPARTMENTS				
COMPT	DOORS	OPENING DIMENSIONS	INSIDE DIMENSIONS	VOLUME
R1	ROLL-UP	37.5" w X 55.4" h	43.1" w X 66" h X 25.8" d	38.7 CU. FT. (10" h X 10.5" d UPPER)
R2	ROLL-UP	57.5" w X 26.2" h	61.6" w X 36.8" h X 25.8" d	28.4 CU. FT. (10" h X 10.5" d UPPER)
R3	ROLL-UP	50.5" w X 55.4" h	53.4" w X 66" h X 25.8" d	47.9 CU. FT. (10" h X 10.5" d UPPER)
REAR STEP COMPARTMENT				
COMPT	DOORS	OPENING DIMENSIONS	INSIDE DIMENSIONS	VOLUME
A1	ROLL-UP	40.5" w X 18.8" h	28" h X 43" w X 31" d	21.6 CU. FT.
TOTAL:				251.4 CU.FT.

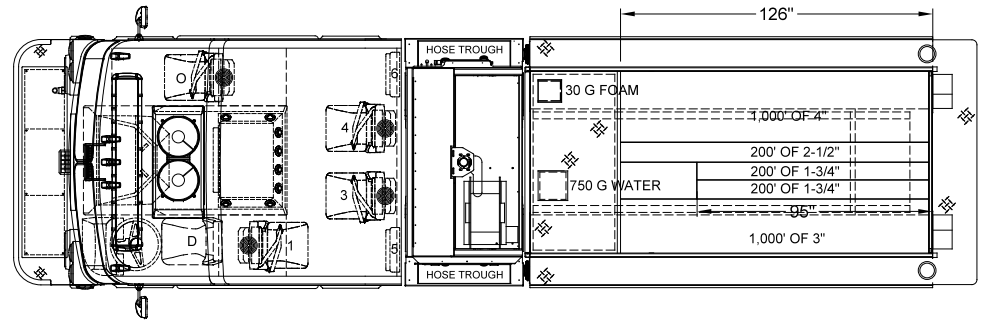

TWO-TONE CAB & BODY
PAINT BREAK OPTION #1
TOP OF BODY COMPTS
BLACK OVER RED

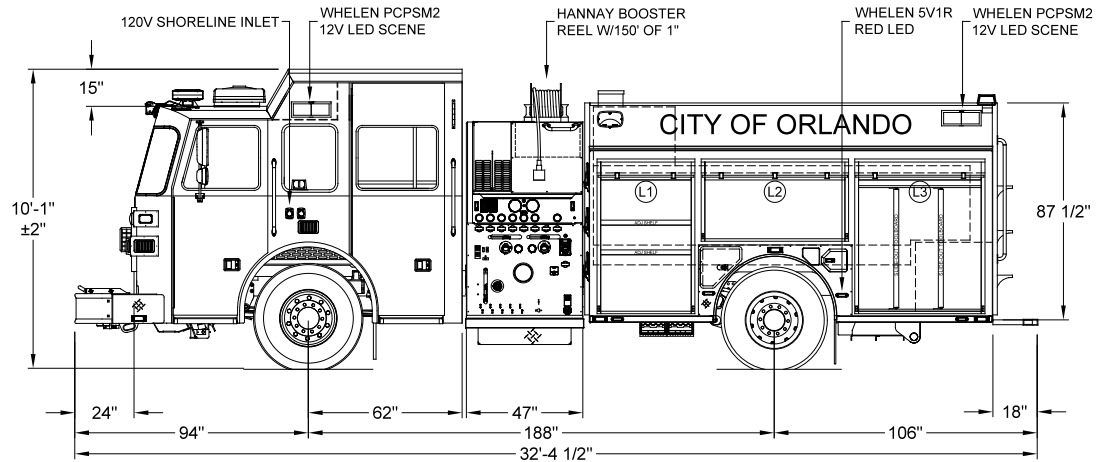
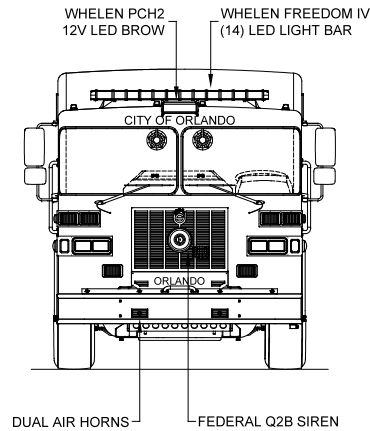

DIMENSIONS SHOWN ON THIS DRAWING ARE APPROXIMATE AND ARE SUBJECT TO MINOR DEVIATIONS DURING CONSTRUCTION.

CUSTOMER APPROVAL

NAME: _____

TITLE: _____

DATE: _____

REV	DESCRIPTION	BY	DATE
B	SEVERAL MINOR CHANGES / CLARIFICATIONS - SEE SO CHANGE SUMMARY ON SHARED OR REVISION EMAIL	RM	09/18/19
A	REV-A SHOP ORDER	RM	05/23/19

DRAWN BY:
R MILLER
DATE:
04/20/19
MFG. FACILITY:
DUBLIN

ORLANDO FIRE DEPARTMENT
ORLANDO, FL
CUSTOM PUMPER - S9
DWG. NO.: HS-6471-73