



SUTPHEN

C SERIES COMMERCIAL TRUCK

OPERATOR AND MAINTENANCE MANUAL



SUTPHEN

IMPORTANT

READ AND UNDERSTAND THIS MANUAL BEFORE OPERATING

FAILURE TO USE, UNDERSTAND, AND FOLLOW PROPER USAGE INSTRUCTIONS AS MADE AVAILABLE BY SUTPHEN CORPORATION/ OPERATOR'S MANUAL, VARIOUS VENDOR SUPPLIED LITERATURE, GUIDELINES OF N.F.P.A., I.S.F.S.I., O.S.H.A., ETC., COULD CAUSE SERIOUS INJURY AND/OR DEATH.

SUTPHEN
Since 1890



Chapter 1

Introduction and General Description

1.1	Introduction	1-5
-----	--------------------	-----

Chapter 2

Safety

2.1	Recommended Training by Fire Department Personnel	2-3
2.2	Fire Chief or Training Officer	2-4
2.3	Operator's Responsibilities	2-4
2.4	Safety Instructions	2-5
2.5	Warning Labels	2-5

Chapter 3

Operation

3.1	Engine Warm-up	3-3
3.2	Transmission Warm-up	3-3
	<i>Automatic Transmission</i>	3-3
3.3	Air System	3-3
3.4	Pre-driving Tips	3-4
3.5	Fire Pump Engagement with Allison EVS 3000/EVS 4000 Transmission with Air Pump Shift	3-5
	<i>Place Main Fire Pump in Gear</i>	3-5
	<i>Pump Shift Emergency Override Operation</i>	3-5
3.6	Shifting Instructions	3-6
	<i>Electric or Pneumatic Pump Shift</i>	3-6



Chapter 4
Maintenance

4.1	Driver's Daily Checklist	4-4
	<i>Daily Checks</i>	4-4
	<i>Engine Oil Level</i>	4-4
	<i>Drive Belts</i>	4-5
	<i>Radiator Coolant Level</i>	4-5
	<i>Fuel Tank</i>	4-5
	<i>Dry-Type Air Cleaner</i>	4-5
	<i>Tires and Wheels</i>	4-6
	<i>Inspection</i>	4-7
	<i>Tightening Cap Nuts</i>	4-7
	<i>Air System</i>	4-8
	<i>Automatic Transmission</i>	4-8
	<i>Fire Pump</i>	4-8
	<i>Miscellaneous Items to Check</i>	4-8
4.2	Preventive Maintenance	4-9
4.3	Maintenance Schedule	4-10
4.4	Details of Maintenance Schedule.....	4-16
	<i>Check: 250 Hours (Schedule 3)</i>	4-16
	<i>Check: 500 Hours (Schedule 4)</i>	4-17
	<i>Check: 1500 Hours - (Schedule 5)</i>	4-18
	<i>Check: Annually (Schedule 6)</i>	4-19
4.5	Monthly Body Preventive Maintenance (Check List)	4-20
4.6	Cab and Body Washing and Care	4-21
4.7	Appearance - Cleaning Body	4-22



	<i>Painted Surfaces</i>	4-22
	<i>Cleaning Underbody, Chassis, and Cab</i>	4-22
	<i>Stainless Steel, Aluminum, and Chrome Surfaces</i>	4-23
	<i>Background Information</i>	4-23
	<i>Recommended Cleaning Procedure</i>	4-24
	<i>Goldleaf Maintenance - Hand-applied</i>	4-25
	<i>Laminated Gold Leaf</i>	4-25
	<i>Not Covered</i>	4-25
	<i>Cleaning Graphics</i>	4-25
	<i>Hand Washing Exterior Graphics</i>	4-26
4.8	<i>Five-year Material Warranty</i>	4-26
	<i>Covers:</i>	4-26
	<i>Coverage:</i>	4-26
	<i>Not Covered:</i>	4-27
4.9	<i>Technical Bulletin</i>	4-28
	<i>Information on Magnesium Chloride and Calcium Chloride</i>	4-28
4.10	<i>Primers</i>	4-32
	<i>ESP Priming Pump</i>	4-32
	<i>Trident Primer Air Switch Connections</i>	4-35
	<i>Trident Air Prime</i>	4-36
4.11	<i>Hale Midship Pump Maintenance Checklist</i>	4-37
	<i>Recommended Weekly Procedures</i>	4-37
	<i>Recommended Annual Procedures</i>	4-38
4.12	<i>Pump Checklist</i>	4-39
4.13	<i>Draining and Winterizing</i>	4-40



Chapter 5

Warranty

5.1 Sutphen Standard Vehicle Warranty 5-3



Chapter 1

Introduction and General Description

1.1 Introduction 1-5



February 2026

CONTACTS FOR SERVICE AND/OR PARTS

If you have a need for SERVICE, TECHNICAL SUPPORT, WARRANTY CLAIM, OR
NEW PARTS, please contact the appropriate personnel below:

Service Support: service@sutphen.com

Tech Support: techsupport@sutphen.com

Training: training@sutphen.com

Warranty: warranty@sutphen.com

Parts: parts@sutphen.com

SUTPHEN CORPORATION - Service & Technical Divisions

935 S. Edgewood Avenue

Urbana, OH. 43078

1-866-287-5549 or 937-969-8851

Fax: 937-969-8869

April 2008

NOTICE

UPON TRANSFER OF OWNERSHIP

- IT SHALL BE THE RESPONSIBILITY OF THE SELLER TO PROVIDE THE MANUFACTURER'S MANUAL(S) FOR THE APPARATUS TO THE PURCHASER.
- IT IS THE RESPONSIBILITY OF THE PURCHASER TO NOTIFY THE MANUFACTURER OF THE UNIT MODEL AND SERIAL NUMBER AND THE NAME AND ADDRESS OF THE NEW OWNER WITHIN 60 DAYS.

UPON TRANSFER OF OWNERSHIP, COMPLETE THE FOLLOWING
(Please Print) AND MAIL TO:

SUTPHEN CORPORATION
7000 Columbus-Marysville Road
PO Box 158
Amlin, OH 43002-0158
Attn: Sales Department

Sutphen Apparatus: Model _____ (i.e. aerial, pumper, etc.)

VIN _____ HS No. _____

NAME OF NEW OWNER: _____

MAILING ADDRESS: _____

FIRE CHIEF: _____ PHONE (____) _____

MECHANIC: _____ PHONE (____) _____

ADDRESS OF MAINTENANCE FACILITY (If different from above mailing address):

DATE OF TRANSFER OF OWNERSHIP: _____



1.1 Introduction

This manual provides important information to familiarize you with safe operating and maintenance procedures for your Sutphen truck. You may be acquainted with similar equipment, but you must read and understand this operator's manual before operating the truck.

Safe operation depends on reliable equipment and the use of proper operating procedures. Performing the checks and services described in this manual will help to keep your truck in good condition. These recommended operational procedures will help you avoid unsafe practices.

This manual is divided into five sections:

SECTION 1 - INTRODUCTION

SECTION 2 - SAFETY

SECTION 3 - OPERATION

SECTION 4 - MAINTENANCE

SECTION 5 - WARRANTY

We strongly recommend that any system on your truck be serviced by experienced mechanics or at a component manufacturer's service facility.

Introduction and General Description

Sutphen Corporation recommends, where possible, using National Testing and Underwriters Laboratories Inc. for aerial inspections. They are recognized nationally and have been thoroughly trained and are familiar with the Sutphen unit, as they do the aerial inspection inside the factory while the truck is in various stages.

Jim Kelker

Pat Ginnaty-Moore

is as

Underwriters Laboratories Inc.

1480 James Parkway

333 Pfingsten Road

Heath, OH 43056

Northbrook, IL 60062-2096

Phone: 800-333-8629

Phone: 847-664-2366

There are several independent testing companies having limited knowledge or experience with our unit; however, they tend to have more problems understanding Sutphen apparatus.

Sutphen trucks are built to conform to all Federal Standards and Regulations applicable at the time of manufacture. Sutphen Corporation cannot be held liable for any unapproved alterations to systems or components, certified or otherwise.



CAUTION

Do not weld to or make any alterations or add any devices to the aerial device without first consulting Sutphen Corporation for approval.



Introduction and General Description

NOTES

Lined area for notes, consisting of multiple horizontal lines.



Chapter 2 Safety

This chapter contains safety guidelines for operating Sutphen vehicles. It describes safety instructions included throughout this manual, lists safety precautions to follow when operating or working on the vehicle, and describes safety practices.

2.1	Recommended Training by Fire Department Personnel.....	2-3
2.2	Fire Chief or Training Officer.....	2-4
2.3	Operator's Responsibilities.....	2-4
2.4	Safety Instructions.....	2-5
2.5	Warning Labels	2-5

▽ **Safety**

NOTES

(This area contains horizontal lines for handwritten notes.)



2.1 Recommended Training by Fire Department Personnel

After each trainee is familiar and reasonably proficient with operation, the unit should be moved to several different sites that simulate actual fire situations typical of your area.

Each operator should be given the chance to observe and operate the boom in these conditions. The Sutphen platform is equipped with proportional controls for all movements. With practice, each operator should be able to move the boom smoothly and accurately to the desired position. The process should soon be second nature, which will then permit the operator to give his/her attention to the unusual aspects of any particular situation.

The following recommendations are invaluable aids to ensuring the safe, efficient operation of the platform and to minimize hazards to people and property.

- 1.** Assign operators for the operation of the unit.
- 2.** Be certain that all operators assigned to the unit have undergone a training course which included:
 - a.** Study of this manual
 - b.** Supervised practice in an open area, until they control the boom smoothly and naturally.
 - c.** A training stint which includes placing the unit, erecting the boom, and discharging water at several sites which simulate actual fire conditions for your area.
- 3.** Each assigned operator must be familiar with the capacities and operating procedures for the unit.
- 4.** A periodic review of the precautions that must be observed for safe operations.
- 5.** Have repairs and adjustments performed only by qualified mechanics who have a working familiarity with pertinent contents of this manual.

Training rev. 8/03

 **Safety**

2.2 Fire Chief or Training Officer

1. Sutphen recommends the manual be thoroughly read and studied before trying to operate this piece of apparatus.
2. Sutphen further recommends that this manual be readily available to persons operating and/or servicing this equipment.
3. Sutphen also recommends that no operator drive or work on Sutphen apparatus without being trained by the Training Officer or person(s) attending the Demonstration of Operation.
4. We recommend that the driver be certified and be CDL licensed before driving the apparatus.
5. When replacing parts on your Sutphen Truck, use only Sutphen-approved parts. When parts are purchased from Sutphen, or an approved Sutphen service center, they are to be installed by a qualified person, or warranty will be void, and Sutphen will not assume any liability.

We recommend the above to eliminate any potential injury resulting from the misuse or negligence on the part of the operator. It is so important to have properly informed personnel to operate the Sutphen apparatus.

2.3 Operator's Responsibilities

The safe and reliable operation of this vehicle includes a thorough working knowledge of all its mechanical components. When checking the vehicle over or driving it, you should be able to recognize problems when they exist and determine if your truck can be driven without affecting its safe operation or causing more serious mechanical problems. When work is required, you should be able to report accurately on the problem.



2.4 Safety Instructions

Safety instructions are noted throughout this manual. Each safety instruction is given as a **WARNING** or a **CAUTION** and is accompanied by a safety symbol in the left-hand margin as shown below:



WARNING

*Failure to observe a safety instruction noted by **WARNING** could result in severe injury or death.*



CAUTION

*Failure to observe a safety instruction noted by **CAUTION** could result in injury or damage to the equipment.*

NOTE: Used throughout this manual, **NOTES** provide useful additional data, but are never used to communicate safety hazards.

2.5 Warning Labels

Warning labels indicate special hazards in and around the vehicle. Read all warning labels and follow instructions on them. .



Chapter 3 Operation

	<u>Page</u>
3.1 Engine Warm-up	3-3
3.2 Transmission Warm-up.....	3-3
<i>Automatic Transmission</i>	3-3
3.3 Air System.....	3-3
3.4 Predriving Tips.....	3-4
3.5 Fire Pump Engagement with Allison EVS 3000/EVS 4000 Transmission with Air Pump Shift.....	3-5
<i>Place Main Fire Pump in Gear</i>	3-5
<i>Pump Shift Emergency Override Operation</i>	3-5
3.6 Shifting Instructions.....	3-6
<i>Electric or Pneumatic Pump Shift</i>	3-6



3.1 Engine Warm-up

After engine starts, let it idle while you check oil pressure, air pressure, and alternator output. The engine should be brought up to operating temperature gradually while oil films are reestablished between pistons and liners, shafts, and bearings.

In colder climates, when temperature is often below 32°F, the warm-up period for turbocharged engines is especially important. The chilled external oil lines leading to the turbocharger will tend to slow oil flow until the oil warms up. Slow oil flow to turbocharger reduces oil available for bearings. Watch engine temperature or oil pressure gauge for a warming trend before increasing engine idle rpm.

After a couple of minutes of idling at 650 rpm, increase engine speed to 900 or 1000 rpm and continue warm-up. This procedure allows the oil to warm up and flow freely while pistons, liners, shafts, and bearings expand slowly and evenly. Idling the engine too slowly does not allow sufficient splash lubrication of cylinder walls and may result in excessive wearing of pistons and liners. Idling too fast during warm-up will cause too rapid and uneven expansion, resulting in premature engine wear.

Continue the warm-up until the coolant temperature reaches at least 130 °F. At this temperature, part throttle is permissible. Do not operate at full throttle until the coolant temperature is at least 160°F.

3.2 Transmission Warm-up

Automatic Transmission

Leave in NEUTRAL. This lets all parts turn, except the output shaft, and will warm fluid in the transmission.

3.3 Air System

Observe the system air pressure gauge, while the engine is warming up, to be sure the reservoir air pressure is increasing. The low air pressure warning light will go out. Do not release the parking brake nor attempt to move the vehicle until air pressure is at least 90 psi.

▽ **Operation**

3.4 PreDriving Tips



WARNING

Driver's Footwear

Sutphen Corporation, at no time, recommends driving apparatus while wearing fireman's structural or large boots. Due to the size of the brake pedal and the throttle pedal, there is better control when not wearing structural fire fighting or large boots.

1. Adjust seat(s).
2. Fasten seatbelt and make sure all other passengers have seatbelts on.
3. Check ALL operating temperatures and pressures are within normal range.
4. Check to see that the interaxle differential (if tandem axle) is unlocked.
5. Check service brake operation and air pressure gauges.

Per NFPA 1901 guidelines, "Fire helmets shall not be worn by persons riding in enclosed driving and crew areas. Fire helmets are not designed for crash protection and they will interfere with the protection provided by head rests. The use of seat belts is essential to protecting fire fighters during driving."



3.5 Fire Pump Engagement with Allison EVS 3000/EVS 4000 Transmission with Air Pump Shift

Engine must be at idle rpm.

Place Main Fire Pump in Gear



CAUTION

Do not pump the truck unless light is on.

1. Truck must be stopped and parking brake set.
2. Truck transmission must be in NEUTRAL position.
3. Brake pedal must be depressed.
4. Move the in-cab pump shift control valve from the ROAD position to the PUMP position. Pause in neutral position briefly before finishing full shift to deplete all air out of line. The shift warning lights should come on in a second or two, indicating a completed shift. (Wait about 2 seconds to allow pump gears to make full travel to complete engagement). At the same time the pump shift is activated, the lock-up for the automatic transmission has also been engaged but is delayed until this device will hold the transmission in the pumping gear position.
5. Shift transmission to D position. Power from the engine is now being transferred to the pump drive gear and pump impellers are turning. Check to make sure the pump is in gear. The green light must be on and speedometer registering. If not, repeat steps 2, 3, and 4 and see if light comes on. If light does not come on, inspect and correct problem and lockup light will come on when true lockup is obtained. Operator is free to move to pump operator's panel and the tachometer at pump panel is working, as it will not work unless in pump gear.

Operation

Pump Shift Emergency Override Operation

1. Put transmission in NEUTRAL.
2. Put PUMP POWER SHIFT in the center position.
3. At pump panel, pull out on PUMP OVERRIDE CABLE.
4. In cab, shift transmission into 1-4 range.
5. Put PUMP POWER SHIFT in PUMP POSITION. That will transfer the power to pump panel.

3.6 Shifting Instructions



WARNING

Failure to properly shift transmission may result in unexpected truck movement, which may result in serious personal injury or death.

Electric or Pneumatic Pump Shift

Shift to PUMP as follows:

1. Bring truck to a complete stop.
2. Reduce engine to idle speed, put truck transmission in NEUTRAL.
3. Set truck parking brake.
4. Move pump shift control to PUMP position.
5. Wait at least four seconds.
6. Shift truck transmission into pumping gear.



CAUTION

Shifting truck transmission into pumping gear above engine idle speed may cause damage to the equipment.

7. Green PUMP ENGAGED and OK TO PUMP lights should be on.



CAUTION

If green OK TO PUMP light is not on, momentarily shift truck transmission into REVERSE, then NEUTRAL, then back into pumping gear. Green OK TO PUMP light should be on. If green light is not on, use manual override if so equipped.

8. Increase engine speed above idle and hold for a few seconds. Watch speedometer to make sure it shows some value of road speed.

NOTE: Some trucks have a speedometer that will not show a value of road speed in a stationary position.



WARNING

If the truck attempts to move, reduce engine speed to idle. Put truck transmission in NEUTRAL and repeat shifting instructions.

9. After leaving truck cab, block wheels using wheel chocks.

Shift to ROAD as follows:

1. With engine speed at idle, put truck transmission in NEUTRAL.
2. When speedometer slows to zero, move pump shift control to ROAD position.
3. Wait at least four seconds before engaging truck transmission.



CAUTION

If you hear a loud grinding noise when you attempt to move the truck, the shift to ROAD has not been completed. Shift into NEUTRAL, wait for grinding noise to stop and reengage truck transmission.

NOTE: If grinding is a common occurrence, it may be prevented by first shifting truck transmission into REVERSE after completing Step 3.



Chapter 4 Maintenance

	<u>Page</u>
4.1 Driver's Daily Checklist	4-4
<i>Daily Checks</i>	4-4
<i>Engine Oil Level</i>	4-4
<i>Drive Belts</i>	4-5
<i>Radiator Coolant Level</i>	4-5
<i>Fuel Tank</i>	4-5
<i>Dry-Type Air Cleaner</i>	4-5
<i>Tires and Wheels</i>	4-6
<i>Inspection</i>	4-7
<i>Tightening Cap Nuts</i>	4-7
<i>Air System</i>	4-8
<i>Automatic Transmission</i>	4-8
<i>Fire Pump</i>	4-8
<i>Miscellaneous Items to Check</i>	4-8
4.2 Preventive Maintenance	4-9
4.3 Maintenance Schedule	4-10
4.4 Details of Maintenance Schedule.....	4-16
<i>Check: 250 Hours (Schedule 3)</i>	4-16
<i>Check: 500 Hours (Schedule 4)</i>	4-17
<i>Check: 1500 Hours - (Schedule 5)</i>	4-18
<i>Check: Annually (Schedule 6)</i>	4-19
4.5 Monthly Body Preventive Maintenance (Check List)	4-20
4.6 Cab and Body Washing and Care	4-21



Maintenance

4.7	Appearance - Cleaning Body	4-22
	<i>Painted Surfaces</i>	4-22
	<i>Cleaning Underbody, Chassis, and Cab</i>	4-22
	<i>Stainless Steel, Aluminum, and Chrome Surfaces</i>	4-23
	<i>Background Information</i>	4-23
	Recommended Cleaning Procedure.....	4-24
	<i>Goldleaf Maintenance - Hand-applied</i>	4-25
	<i>Laminated Gold Leaf</i>	4-25
	<i>Not Covered</i>	4-25
	<i>Cleaning Graphics</i>	4-25
	<i>Hand Washing Exterior Graphics</i>	4-26
4.8	Five-year Material Warranty	4-26
	<i>Covers:</i>	4-26
	<i>Coverage:</i>	4-26
	<i>Not Covered:</i>	4-27
4.9	Technical Bulletin	4-28
	<i>Information on Magnesium Chloride and Calcium Chloride</i>	4-28
4.10	Primers	4-32
	<i>ESP Priming Pump</i>	4-32
	<i>Trident Primer Air Switch Connections</i>	4-35
	<i>Trident Air Prime</i>	4-36
4.11	Hale Midship Pump Maintenance Checklist.....	4-37
	<i>Recommended Weekly Procedures</i>	4-37
	<i>Recommended Annual Procedures</i>	4-38
4.12	Pump Checklist.....	4-39
4.13	Draining and Winterizing.....	4-40

4.1 Driver's Daily Checklist

To make sure your truck is ready for service, make the following daily inspections.

Daily Checks

Before starting each day, check or inspect the following to ensure trouble-free performance.

1. Make visual inspection of entire unit.
2. Check under vehicle for signs of leaks. If any are noted, correct condition causing leaks.
3. Check all liquid levels on chassis: engine and transmission oil, coolant level, power steering pump, and all other oil and liquid levels. Also check engine belts, hoses, and wiring for condition and adjust as needed.

For more details, read below.

Engine Oil Level

With the engine stopped, check for oil leaks and oil quantity on the dipstick. If engine was running recently, allow five minutes for oil to drain into crankcase. Use only recommended engine oil. DO NOT mix engine oils, either by weights or type. Do not overfill the crankcase. NEVER operate the engine if oil quantity is below the low-level mark. Factory-delivered unit will be full of 15W40, 4-cycle oil.

Drive Belts

Check condition and tension of fan belt and accessory drive belts.



Radiator Coolant Level

A sight glass is provided on the recovery tank for checking coolant for proper level.



WARNING

Check coolant when engine is cold. If cap must be removed when engine is hot, use extreme care. Place heavy cloth over cap and turn cap slowly, allowing radiator pressure to bleed off. If truck has surge tank on cooling system, check same as above.

NOTE: Coolant must contain some type of corrosion inhibitor. When operating in freezing weather, use ethylene glycol base antifreeze.



CAUTION

When draining and refilling the cooling system, use the following procedure to avoid air traps:

1. Fill radiator until coolant is to top of sight glass.
2. Run the engine for one minute at 700-1000 rpm.
3. Stop engine and recheck coolant level. Top off as necessary to bottom of filler neck.
4. Add in correct amount of coolant (Reference chassis manual for brand and type).

Fuel Tank

Visually check fuel level gauge. Visually check exterior of tank for any leaks.

NOTE: Topping off with fuel at the end of each work day will reduce water condensation in the tank.

Dry-Type Air Cleaner

When the air restriction light (green indicator) on the dash is on, it is time to clean the filter. Remove the air filter and clean the filter element (reference chassis manual for brand and type).

Tires and Wheels



WARNING

Always maintain your tires in good condition. Frequently check and maintain correct inflation pressures as specified by the tire manufacturers. Inspect periodically for abnormal wear patterns and replace/repair cut or broken tire casing. Always use experienced, trained personnel with proper equipment and correct procedures to mount or remove tires. Failure to adhere to these warnings could result in tire malfunction, damage to the vehicle, personal injury, and possibly death.

Inspection

NOTE: Correct inflation pressure should be on sidewall of tire.

Check and maintain the correct inflation pressure for each tire every morning or when tires are cool. Check tire pressures **ONLY** when the tires are cool. Warm or hot tires cause pressure buildup. Do not deflate a warm tire to specified pressure. Tire thumping during the walk around inspection will tell you if a tire is deflated, but the only way to check tire pressure is with an accurate gauge. If any tires are found to be considerably under inflated, the vehicle should not be driven until cause of the leak is determined and repairs have been made.

Regular and frequent inspection and proper care will give you the assurance of safe, reliable tire operation. Most tire wear problems are caused by under inflation such as a slow leak. Low pressure is a tire's worst enemy. It allows tires to flex badly and this causes high temperatures to build up. Heat causes early tire damage, such as flex breaks, radial cracks, and ply separation. Furthermore, low tire pressures can affect control of your vehicle particularly at the front wheels.

Look for bumps, blisters, cuts, punctures, cracks, proper inflation, uneven wearing, and tread depth. Rotate tire from front axle to rear axle position when tread is worn to 1/8 in. (3.175 mm). Replace tire on rear axle when tread is worn to 1/16 in. (1.588 mm).



Contrary to an old idea that refuses to die, letting air out of tires for more traction on ice or snow does not work. Low inflation actually reduces traction and steering control. Overloading your truck can be as hard on tires as under inflation. The following chart shows the proper air inflation of tires to increase the tire's life:

Tightening Cap Nuts



CAUTION

Lubricants should not be applied to the cap nut seats or to the wheel. Lubricants must be wiped from the cap nut seats if applied accidentally.

Impact wrenches, if used, should be carefully adjusted to apply torques within the limits recommended. Torquing of cap nuts should be done in recommended sequence. Cap nuts must be kept tight, and studs and nuts should be checked frequently. At tire changes, nuts and studs should be inspected to be sure they are in good condition. If nuts require frequent tightening, studs break frequently or wheel nut seats are rounding out. Hardware and mounting practices should be reviewed.



CAUTION

Check all parts, including wheels, rings, mounting face of hubs, and studs. Check for dirt, corrosion, or damage. Remove dirt and rust; replace damaged parts. Follow the correct tightening sequence and recommended torque levels. Overtorque can cause overstressed studs and cap nuts, damaged threads, and damaged wheels. Insufficient torque can cause stud breakage and damaged wheels.

NOTE: When dualing steel wheels with Alcoa aluminum wheels, follow the steel wheel manufacturer's recommendations regarding the proper torque and use of thread lubricants to mount the wheel.

On vehicles equipped to accept wheels manufactured for use with the stud-located ball seat mounting system, wheel studs on the right side of the vehicle have right-hand threads and those on the left have left-hand threads. The R and L on the studs and nuts indicate right and left hand threads respectively.

 **Maintenance**

Air System

Be sure all air tank reservoir drain cocks are shut off and check for any leaks and repair if necessary.

Automatic Transmission

Determine if there is enough oil in transmission to safely start the engine. With engine stopped, oil level should be well above the FULL mark. The parking brake must be set and the selector lever must be in NEUTRAL with transmission hot, and the truck engine at idle to get accurate reading. The dipstick has an ADD and FULL mark, so you know when to add oil. Check only when truck engine is running, and transmission is in NEUTRAL, and brake is set. Transmission level can also be checked with the shifter. See Shifter Manual.

Fire Pump

On Hale pumps, check pump gear case oil level by pulling out plug on front, right, lower pump gearbox. On a Waterous gearbox, oil level is checked with a sight glass.

Check to be sure no water is mixed in.

Miscellaneous Items to Check

1. Check low and high beam headlights.
2. Check operation of turn signals and emergency flashers and emergency warning lights.
3. Check driving mirrors for adjustment and clean.
4. Fuel tank cap secure.
5. All compartment doors shut tight.
6. All equipment is secured.
7. Check windshield washer fluid level.
8. Check to see if the air and electrical horns and siren work.
9. Check water tank level.
10. If engine has an air shutdown device, make sure it has been manually reset if pulled.



4.2 Preventive Maintenance

The Preventive Maintenance Program really starts with the daily checks that you perform. These checks are itemized in the Maintenance Schedule.

The following charts cover information on the lubrication of the chassis and periodic maintenance schedules, which must be performed on this vehicle. This information is put together to keep the truck in good running condition throughout the truck's life.

The maintenance schedule is set up using hourly intervals. It is divided into:

- Daily or every 10 hours
- Weekly or every 50 hours
- 250 hours
- 500 hours
- 3000 hours or annually

Severe service conditions may dictate more frequent intervals.

REMEMBER - PREVENTIVE MAINTENANCE IS LIKE BUYING TIME!

Maintenance

4.3 Maintenance Schedule

Schedule 1: Daily or Every 10 Hours

	Check	Clean	Lube	Replace	Adjust
Engine Oil Level	X				
Transmission Oil Level	X				
Safety Equip. Warning	X				
Light & Devices	X				
Instruments, Gauges, & Controls	X				
Check for Leakage Under Truck	X				
Radiator Coolant Level	X				If Necessary
Engine Cooling Fan	X				



Schedule 2: Weekly or Every 50 Hours

	Check	Clean	Lube	Replace	Adjust
Complete Schedule 1	X				
Engine (See Engine Manual)	X				
Wheel Lugs (Torque)	X				X
Battery Fluid Level	X				
Fan Belt, Alternator Belt	X				X
Differential & Axle (Front & Rear) (See Axle Manual)	X				
Radiator Coolant Level & Connections	X				
Tire Pressure	X				
Drain Water From Fuel	X				
Separator - Racor	X				
Fire Pump, Oil Level & Priming	X				X
Pump Reservoir	X				
Manual Air Tank Drains	X				
Windshield Washer Fluid Level	X				
Driveshaft U-Joint Torque	X				

Maintenance

Schedule 3: Every 250 Hours

	Check	Clean	Lube	Replace	Adjust
Complete Schedules 1 & 2	X				
Lubricate Fittings (See Lubrication Chart)	X				
Engine Components (See Engine Manual)	X				
Power Steering Fluid Level	X				
Axle Components (See Axle Manual)	X				
Air Cleaner	X				
Modulator Cable, Cable Ends	X	X	X		
Pump Shifter Cable, Cable Ends	X	X	X		
Diesel Fuel Filters	X			X	
Engine Oil & Filter	X			X	
Nalcool 3000	X			X	
Air Dryer for Operation	X				
Coolant Filter	X			X	
Coolant SCA Concentration Level	X				
Intake Air Piping & CAC System	X				
Driveshaft U-Joint	X	X	X		X



Schedule 4: Every 500 Hours

	Check	Clean	Lube	Replace	Adjust
Complete Schedules 1, 2, & 3	X				
Engine Coolant	X			X	
Air Compressor Filter	X			X	
Automatic Slack Adjusters					X
Rear Tandem Rotation of Tires	X				X

Maintenance

Schedule 5: Semiannual or 1500 Hours

	Check	Clean	Lube	Replace	Adjust
Complete Schedules 1, 2, 3, & 4	X				
Engine Components (See Engine Manual)	X				
Wheel Bearings (See Axle Manual)	X				
Transmission Oil & Filter				X	
Clutch Pedal Travel/Clutch Lube	X		X		
Radiator Fins Clean	X	X			
Fire Pump Oil				X	
Axle Mounting U-Bolts	X				X
Cab Mounting Bolts (6)	X				X
All Bolts and Nuts	X				X
Steering Gear Mounting Bolts	X				X
Tightness of all Joints on Muffler System	X				X
Body Mounting bolts	X				X
Electric Lines for Connection	X				
Wear and Corrosion	X	X		X	
Air Line System	X				
Pump Mounting Bolts		X			
Body Mounting U-Bolts		X			
Power Wash Underbody and Cab with Wide Fan on Nozzle	X	X			
Wire Brush All Rust, Corrosion, and unpainted Areas and Touch Up These Areas with Primer, Paint, and Undercoating	X	X		X	
Power Steering Wheel Shaft Nut	X				X
Check & Retorque Bolts on Front & Rear Motor & Transmission Mounts to 210 ft/lb	X				X



Schedule 6: Annual or 3000 Hours

	Check	Clean	Lube	Replace	Adjust
Complete Schedules 1, 2, 3, 4, & 5	X				
Air Dryer Cartridge Element				X	
Tire Condition	X				
Manual Transmission Oil	X				
Brake Linkage, Controls, Lining, & Misc. Parts	X				
Radiator Coolant	X				
Pump Mounting Bolts	X				
Body Mounting U-bolts	X				
Power Wash Underbody and Cab with Wide Fan on Nozzle	X	X			
Wire Brush All Rust, Corrosion, and Unpainted Areas and Touchup These Areas with Primer, Paint, and Undercoating	X	X		X	
Take Truck to Ziebart for Inspection First 10 years Each Year			X		X
Inspect Air Intake Duct in Cab, Clean	X	X			X

4.4 Details of Maintenance Schedule

Check: 250 Hours (Schedule 3)

1. CHECK OIL LEVELS and top off as necessary: transmission, pump, drive axle, power steering reservoir, and oil-lubricated wheel bearing.
2. ENGINE OIL AND FILTER: Change oil and filter.
3. FUEL FILTER: Drain, clean, and refill or replace as necessary.
4. ENGINE COOLANT: Check level and top off as necessary,
5. ENGINE AIR CLEANER: Service element - inspect.
6. AIR INTAKE PIPING AND MOUNTING: Check for condition and security.
7. STEERING LINKAGE: IMPORTANT! Check ALL connections for free play and wear. Check tie rod for straightness. Check drag link tube clamp for interference. Check steering for excessive play and adjust as necessary.
8. DRIVE SHAFT U-JOINTS: Check for wear before lubricating with chassis lube and tighten all bolts and nuts on flanges.

COMPANION FLANGE AND DRIVE SHAFT TORQUE SPECIFICATIONS

- | | |
|----------|--|
| 6-73-220 | BOLT TO ATTACH 1710 COMPANION FLANGE - 40 to 48 FT/LB |
| 7-73-122 | BOLT TO ATTACH 1810 COMPANION FLANGE - 63 to 75 FT/LB |
| 8-73-316 | BOLT TO ATTACH 1710 HALF ROUND DRIVE SHAFTS - 115 to 135 FT/LB |
| 6-73-209 | BOLT TO ATTACH FULL ROUND DRIVE SHAFTS - 38 to 48 FT/LB |

9. FUEL TANK: Drain sediment from tank.
10. BATTERIES: Check condition of terminals. Check electrolyte level (if possible).
11. DRIVE BELTS: Check condition and adjust tension as necessary.
12. When wing nuts are treated with thread locker, replace bolts. Used bolts are to be replaced.



13. CLEAN ALL CABLES at both ends and grease.

- Fire pump shifting cable

14. AIR DRYER OPERATION (See Appendix C - MERITOR WABCO System Saver Series Single Cartridge Air Dryers).

Check: 500 Hours (Schedule 4)

1. Complete all of Schedule 3.
2. ENGINE OIL, FILTER: Change oil and filter.
3. ENGINE COOLANT: Check condition of antifreeze solution and corrosion inhibitor.
4. AIR COMPRESSOR AIR CLEANER: Inspect element and replace as necessary.
5. DRIVE BELTS: Check condition and adjust tension as necessary.
6. WHEEL BEARINGS: Check for end play and adjust as necessary.
7. SLACK ADJUSTERS: Lubricate sparingly. **ALSO CHECK ADJUSTMENT WITH TEMPLATE.**
8. On trucks with disc brakes, check brake pad wear.
9. Check and retorque fire pump mounting bolts to 150 ft/lb.
10. Check and retorque all body mounting U-bolts and all body bolts.

Check: 1500 Hours - (Schedule 5)

1. Complete all of Schedules 3 and 4.
2. ENGINE:
 - a. Clean with steam or solvent.
 - b. Clean crankcase breather, if applicable.
 - c. Tighten manifold nuts to specified torque.
 - d. Tighten oil pan capscrews to specified torque.
 - e. Check drive pulleys for tightness.
 - f. Check turbocharger manifolding, and mounting.
 - g. Check all lines and seals for leaks.

NOTE: For details on specific engine service requirements, refer to the engine manufacturer's maintenance manuals.

3. OIL CHANGES - TRANSMISSION, FIRE PUMP: Drain lubricant while warm. Refill. Check all drain and filler plugs for tightness.
4. AIR COMPRESSOR AIR CLEANER: Replace element.
5. CRANKING MOTOR AND ALTERNATOR: Check operating and output.
6. COOLING SYSTEM: Check radiator and all hoses for leaks, then drain. Correct any leak problems. Flush out system and refill with coolant mix. Check and clean radiator fins as needed.
7. REPLACE Nalcool 3000 when using unfiltered and untreated water while changing coolant.
8. AIR CLEANER: Change, if necessary. Otherwise, just clean the K & N filter with a K & N cleaning kit. Also clean the spark arrestor.
9. SUSPENSION U-BOLTS: Tighten U-bolt nuts to specified torque.
10. ENGINE AIR INTAKE TUBING: Check all tubing joints and mounting points for any leaks that would permit unfiltered air to enter the engine.



11. CHANGE AIR DRYER ELEMENT: Type Bendix-Westinghouse AD-IP or WABCO 1200 (for more information, see Bendix AD-IP or WABCO 1200 manual).
12. WIRING: Check condition of all wiring. Repair or tighten loose terminals.
13. FRONT AXLE: Inspect bearings, knuckle pins, bushing, and spindles.
14. FRONT AND REAR WHEEL BEARINGS (OIL OR GREASE LUBRICATED): Disassemble, clean, inspect, and refill or repack. Adjust bearing play.
15. POWER STEERING RESERVOIR: Change fluid.
16. PARKING (SPRING) BRAKES: Inspect release bolts, clamp rings and bolts, mounting studs, and air lines.
17. CHECK ALL FUEL LINES and other lines for wear.

Check: Annually (Schedule 6)

1. Complete Schedules 3, 4, and 5.
2. HEATER - DEFROSTER: Check function of all controls in both modes.
3. AIR CONDITIONING: Check Freon level for full charge.
4. MOUNTINGS - ENGINE, TRANSMISSION, SUSPENSION, FUEL TANK, AND BATTERY: Check for condition and tightness.
5. FRONT AXLE STEERING SPINDLES: Clean and check for excessive wear and looseness after assembly.
6. FRONT END ALIGNMENT: Check and adjust as necessary.
7. On cabs with side screens, once a year (or more if needed), use a hose and clean out any debris or salt in the passage to engine on both sides of the cab.

Make sure drains are draining properly, front and rear, in the air intake area above fender.

If any surface is not undercoated or painted, it should be touched up with paint and undercoated, and caulk all seams.

 **Maintenance**

If it is required to remove grills, reuse treated screws with green nylon under head (red on thread part of screw). If you should need a new screw, contact Sutphen Corporation to order. Do not use Loctite, as it eats paint, causing corrosion.

4.5 Monthly Body Preventive Maintenance (Check List)

1. Door latches on truck greased and adjusted.
2. Check door seals on all doors. Glue or change rubber as needed.
3. All bolts and nuts on body in place and tight.
 - a. Example: Running boards, catwalk, header, and other miscellaneous places on body and chassis.
4. Replace or tighten bolts as needed.
5. Clean body, compartments, and battery box. For more information, see Paint Maintenance.
6. Make sure booster reels and electric reels work properly, clean and grease chain and linkage with multipurpose oil. Tighten if necessary. Check performance of rewind button and rollers.
7. Make sure brackets and springs are working properly on hard suction and ladder mountings.
8. Check operation on all electric lights on truck for bulbs burned out and make sure they are working properly.
9. Check all electrical receptacles on truck, and make sure they are working properly.
10. Make sure all compartment lights work.
11. Check/start-up generator, and make sure it is working properly.
12. Make sure all equipment on truck is cleaned, greased, and works properly.
13. Check for rust or chipped paint anywhere on body, chassis, or underbody or in compartments. If rust or corrosion starts, clean, wire brush, prime, and paint. Semiannually, before and after winter, power wash underbody chassis and cab and do above steps, then undercoat to seal up areas to prevent return of damage in the future.



14. Remove all equipment from all compartments monthly. Clean out dirt and touch up paint and wax inside compartment. Check to see if all seams are caulked to prevent water leaking between seams. Replace caulking as needed.
15. Touch up paint on overall truck as soon as paint is chipped. Clean, prime, and paint.
16. Take truck to Ziebart for inspection once a year for first 10 years.

4.6 Cab and Body Washing and Care



WARNING

Failure to follow procedures may void warranty.

1. Wash the apparatus AS NEEDED. To remove light dust, wipe off with a clean damp cotton towel or chamois. Always use a separate cloth or sponge when washing the painted surfaces. The other areas, such as steps, bumpers, and tread plate, could leave abrasive materials on the cloth or sponge that could scratch the painted surfaces. Never use shop rags.
2. Wash off all salts, highway deicers, petroleum, industrial fallout, and chemicals as soon as possible. All exterior surfaces should be washed (top, sides, under cab, and underbody).
3. To wash, use warm water, mild soap, and cotton towels. Use caution when pressure washing. Always use a wide fan, and care must be taken not to get too close to the vehicle or any striping, lettering, labels, or vinyl overlay.
4. After washing, always wipe dry with soft cotton towels or chamois. Never allow the apparatus to stand wet in a closed station. Wipe or blow out all compartments after washing the vehicle or after use in wet conditions.
5. For cleanup of road tar, tree sap, and other types of residue, try car wash soap first. If this does not work, spot-use a mild wax and grease remover or a bug and tar remover.
6. For cleanup of surface rust and normal grime in compartments, try car wash soap first. If this does not work, try a mild rubbing compound. Gently rub in circular motion.
7. The apparatus should be waxed a minimum of one time every three months, or more often in the winter due to destructive chemicals used for deicing, salt, etc. All painted and aluminum diamond tread plate surfaces, aluminum, and stainless or chrome miscellaneous items should be waxed to reduce the chance of corrosion from the elements.

Maintenance

8. If equipment is mounted on the apparatus, be certain that all holes are primed, painted, and caulked to prevent corrosion under the paint. Remove all metal or aluminum particles and residue after drilling and sanding to prevent surfaces rusting or corrosion.
9. Periodically, or monthly in the winter months, check apparatus for chips and scratches in the paint and repair them with touch-up paint (furnished or equal paint) upon delivery. Several times a month, wash underneath the apparatus, especially during winter months. If power wash is used, use a fan spray only, or it may damage the undercoating or paint. Then prime, paint, and reundercoat areas where bare metal is showing or rust has started or warranty may be void.
10. If apparatus has Ziebart undercoating, take truck in yearly to Ziebart, for first 10 years, to have undercoat inspected by an authorized Ziebart dealer and they will do any touchup of undercoating under truck for 10 years under Ziebart Warranty.

4.7 Appearance - Cleaning Body

Painted Surfaces

See cleaning policy for more detail and also policy located on inside front left compartment door.

Wash frequently to remove grime and caustic deposits, which could stain the finish. Use cool or lukewarm water. A mild soap may be used. Avoid washing in bright sunlight. Dry truck, especially all compartments and seams. Road tar can be removed with a special commercial tar remover or mineral spirits. Waxing offers added protection against staining and oxidation. Wait approximately 30 days after date of manufacture before waxing to give the finish a chance to cure. DO NOT WAX IN HOT SUN. If a buffing machine is used, take care not to friction-burn the paint. DO NOT BUFF OVER GOLDLEAF. Wax truck monthly to keep the good finish.

Cleaning Underbody, Chassis, and Cab

See monthly body inspection numbers 13, 14, 15, and 16.



Stainless Steel, Aluminum, and Chrome Surfaces

Aluminum wheels and stainless bumpers can be cleaned with warm water. Tar remover will remove deposits of road grime. For added appearance, wipe surfaces dry after washing to prevent spotting. Under corrosive conditions, such as driving on salted roads, clean parts with steam or high pressure water from a hose. Mild soap solution will help. Rinse thoroughly.

Chrome surfaces are best cleaned with fresh water. Wipe dry to preserve luster. Light rust can be successfully removed with any commercial chrome cleaner. After cleaning, wax flat surfaces and apply a thick coat of rust preventive lubricant around bolts or other fasteners.



WARNING

Do not use a hose to clean wheels or undercarriage if truck has just been on a run or driven. Cold water can crack hot brake drums or rotors. Wait until wheels are cool to the touch.

Background Information

1. There are numerous different types of stains. The nature of the stain, its interaction with the vinyl coated fabric, and other variables may make it impossible to totally remove certain stains.
2. There also are numerous different types of commercially available cleaning agents (i.e., Formula 409, Fantastic). Their composition can be changed by the manufacturer without public notice. Because of this, we recommend using these in an inconspicuous spot and check for damage before using these elsewhere. Extended use of these materials is not recommended and usually not needed.
3. This information is provided in good faith. Due to the wide variance in the nature and type of stains and their setting time, in the interactions between the vinyl coated fabric and the staining material, and in the nature and type of cleaning agents, this is only a recommendation offered with no warranty.

Recommended Cleaning Procedure

NOTE: Cleaning should proceed in these steps. Proceed to the next step only if needed.

1. Use a clean wiping material (i.e., paper towel, sponge) to soak up and remove as much of the staining material as possible immediately after the spill occurs. Avoid grinding in the stain in this process
2. Clean the stained area with warm (not hot) mild soap (i.e., Ivory, Dermassage, or similar hand dishwashing soap, not dishwasher soap, or Pine Sol or similar pine oil cleaner) and water solution.
3. Expose the stain to concentrated hand dishwashing liquid (not dishwasher soap) or pine oil cleaner and rub mildly. Follow with warm water wash.
4. Expose the stain to lighter fluid or naphtha (CAUTION this is flammable). Follow with warm, soapy water wash.

NOTE: We recommend that you use the following cleaning agents only after you have tried them in an inconspicuous location and ensure yourself that the agent will not damage anything. These agents should be used for occasional cleaning of stubborn dirt and stain. For everyday cleaning, we recommend a warm water and mild dishwashing liquid. Clean in the following order:

- a. Expose the stain to waterless hand cleaner (i.e., DL Hand Cleaner DL Group, Banite Industries, GOOP, or similar) and rub mildly. Follow with warm, soapy water wash.
- b. Expose the stain to commercially prepared cleaning solution (i.e., Formula 409, Fantastik) per manufacturer's recommendation. Follow with warm, soapy water wash.
- c. Expose the stain to rubbing (70 percent isopropyl alcohol or 70 percent isopropanol). This is available at drug and grocery stores.
- d. If Naugahyde appears dull or flat, you may use Johnson Spray Furniture Wax to bring to a shine. NOT ARMORALL

Occasionally spray weather stripping on doors and windows and fender rubber with silicone compound to help preserve resiliency. This is especially useful in freezing weather to keep doors and windows from sticking shut with ice.



It is good practice to hose the dirt and grime from the whole chassis and body. If a leak develops, it will be more easily detected and will not let dirt accumulate under the truck, causing rust.

Goldleaf Maintenance - Hand-applied

1. When washing, avoid any direct spray of goldleaf.
2. Avoid any hard rubbing of goldleaf when washing, so as not to scratch or damage the goldleaf.
3. Once a year, or more, clear coat all goldleaf with a clear polyurethane to protect the finish. If annually, we recommend this be done in the fall to protect goldleaf from salt and winter harshness. Warranty is voided if not properly maintained.

Laminated Gold Leaf

Proper maintenance will offer you a lifetime of satisfaction! The following will aid in keeping your application looking brand new:

1. No pressure washing of any kind. Sponge wash only!
2. Use straight wax; no polish or abrasive cleaners.
3. Annual inspections, after the initial 6 month requirement.

Not Covered

Damages caused by abuse or failure to perform normal maintenance or any other expense. This warranty shall NOT apply to ANY defect, malfunction or failure to conform with the warranty provisions (not resulting from defect or malfunction) due to unreasonable use by the purchaser.

Consequential damages, incidental damages, or expenses, including damage to property.

Cleaning Graphics

Use a cleaner designed for high-quality painted surfaces. The cleaner must be wet, nonabrasive, without strong solvents, and have a pH value between 3 and 11 (neither strongly acidic nor strongly alkaline).

Hand Washing Exterior Graphics

1. Flush the graphic with clean water to remove loose dirt particles. A trigger-type hose nozzle is convenient for this purpose.
2. Use a mild liquid detergent and water solution and wash the graphic with a soft brush, rag, or sponge.
 - a. Wash thoroughly from the top down.
 - b. Avoid abrading the graphic by unnecessary scrubbing.
 - c. After applying the cleaning solution, keep a steady stream of water flowing on the graphic to wash away dirt particles.
3. Rinse the entire graphic thoroughly with clean water. Allow to dry naturally.

4.8 Five-year Material Warranty

A 100 percent warranty for five (5) years against defects in material for Scotchlite Reflective Graphics Film.

A 100 percent warranty for five (5) years against defects in material for SignGold Graphics Film.

Covers:

Replacement of defective material ONLY.

Coverage:

Warranty coverage is subject to an initial six-month inspection and the completion and return of the service card to keep your warranty valid. All validations are subject to inspection by a master sign craftsman, with written acknowledgment of this action forwarded to Associated Graphics Inc. Proper maintenance will offer you a lifetime of satisfaction! The following will aid in keeping your application looking brand new:

1. No pressure washing of any kind - SPONGE WASH ONLY!
2. Use straight, nonabrasive wax - NO polish or abrasive cleaners.
3. Annual inspections after the initial six-month inspection requirement.



Not Covered:

Damages caused by abuse, failure to perform normal maintenance or faulty or improper installation, whether by purchaser or third-party contractor, will void warranty.

Normal fading, lightening, or discoloration due to exposure to natural or artificial light, elements, normal wear, chemical washes, or acts of God.

AGI is not responsible for any loss, damage, travel expense, labor, or any other consequential damage arising from use or misuse of our products.



CAUTION

Before handling any chemical products, always read the container label and the Material Safety Data Sheet (MSDS).

4.9 Technical Bulletin

Information on Magnesium Chloride and Calcium Chloride

Our Technical Bulletins are provided to inform you of design options, design improvements, standard sizes and changes, different models, applications, installation, operation, and maintenance.

FM-7.5-171

Rev A

11/03/04

This bulletin is to make users of R•O•M products aware of damage that can occur due to chemicals used to de-ice roads. State maintenance crews use several different chemicals as liquid anti-ice or snow and ice-clearing chemicals. See the table below for a list. These chemicals are often sprayed on roadways prior to arrival of storms thereby having longer exposure and not immediately being diluted by snow or water.

Chemical Name	Abbreviation
Calcium Chloride	CaCl ₂
Sodium Chloride (road salt)	NaCl
Magnesium Chloride	MgCl ₂
Calcium Magnesium Acetate	CaMg ₂ {CH ₃ COO} ₂
Potassium Acetate	KC ₂ H ₃ O ₂

Of these, calcium chloride is probably most destructive because it attracts moisture more readily. Calcium chloride absorbs water vapor from air at 40 percent humidity vs. magnesium chloride at 75 percent.



Corrosion from these chemicals is seen on chrome, aluminum, and even stainless steel, and concrete. Significant damage can result from as little as a single winter season.

Since magnesium chloride solution has higher viscosity and stronger hydrophilicity properties than sodium chloride, it adheres and crystallizes on the surfaces of metals under dry conditions and then becomes a corrosive agent when wetted.

If these chemicals are deposited on painted surfaces that have been pitted by rocks or gravel or scratched thereby exposing bare metal, the chemically induced corrosion will eat away at the metal substrate undetected until the paint starts blistering. Therefore, it's very important to replace chipped or scratched paint immediately.

A very aggressive vehicle washing practice is probably the most effective preventative maintenance tool available to operators. It's important to note that a coating of magnesium chloride is extremely difficult to get clean and keep clean. It's also important to note that the washing system should not use recycled water because it generally contains a higher percentage of sodium chloride than water straight from the source. Other corrosion fighting techniques include:

Please provide this information to your engineering, manufacturing, sales and marketing departments and to your dealers.

Copyright © 2004 R•O•M Corporation. All Rights Reserved. These drawings and the information contained herein are the confidential and proprietary intellectual property of R•O•M Corporation and should not be disclosed to any third party without the express prior written consent of R•O•M Corporation.

 **Maintenance**

- Frequently inspect and clean entrapment areas of debris. It is best not to block off or try to seal entrapment areas because, despite your best efforts, corrosion could get started and remain unnoticed.
- Drain holes should be inspected and cleared frequently.
- Proper use of a common ground.
- Frequently inspect and spray electrical connectors with moisture inhibitors.
- Use dielectric grease.
- Frequently inspect structural and safety-related components for corrosion and take immediate corrective action when corrosion is observed.
- Replace chipped or scratched paint immediately after thoroughly cleaning the bare metal and surrounding surface.
- Frequently wax painted surfaces.

R•O•M strongly recommends that our ramp, carrier, and roll-up door products be frequently inspected and maintained. It's extremely important to frequently and thoroughly wash these products to remove the corrosive chemicals deposited as a result of the use of these corrosive snow - and ice - clearing chemicals. Not doing so could result in unwanted corrosion, which may cause unsafe conditions and deteriorate the product appearance, including promoting bubbling of paint coatings.

For more information, visit the following site for an in-depth review of road chemical-induced corrosion.

http://trailer-bodybuilders.com/mag/trucks_corrosion_explosion/index.html



Hale Products, Inc. Service Bulletins

Bulletin#: Revision#: Date:

Product Type Covered: Hale Pump Hurst Tool Lukas Tool

Product Covered:

Problem Statement:

Primer vane life degrades if the recommended annual maintenance is not performed. To provide prolonged primer life Hale recommends the primer be disassembled and cleaned annually or after 500 operational cycles. At this time primer power and ground connections should be checked.

Written by: Date:

Approved by:

Project Manager:

Customer Service Designee:

Body of the Bulletin

Hale ESP rotary vane primers are reliable environmentally friendly devices that with normal use and if properly maintained will provide years of reliable operation. This reliable operation can only be maintained if proper service, as recommended by Hale products is performed.

Failure to perform this required maintenance could void the primer warranty.

Repeated in this document is the recommended annual maintenance for Hale ESP primers. These maintenance procedures are applicable to both 12 VDC and 24 VDC primer models.

The following text is from PL821, PL938 and Figure 3-2 of 029-0020-63-0:

"To aid in long primer life and proper performance, it is recommended that the priming pump be cleaned yearly or after 500 cycles of use. Separate the pump body and head from the motor and remove any black build-up or contaminants with Safety Kleen™ or Stoddard Solvent. Use care to reinstall the vanes in the same orientation and to grease the shaft seal."

Also included in this service bulletin is an updated Midship Pump Maintenance Checklist

The procedure for disassembly, cleaning, vane replacement and reassembly of the priming pump can be found in the Hale muscle pump manual (Hale P/N 029-0020-63-0) and is reprinted here for easy reference.

▼ Maintenance

4.10 Primers

ESP Priming Pump

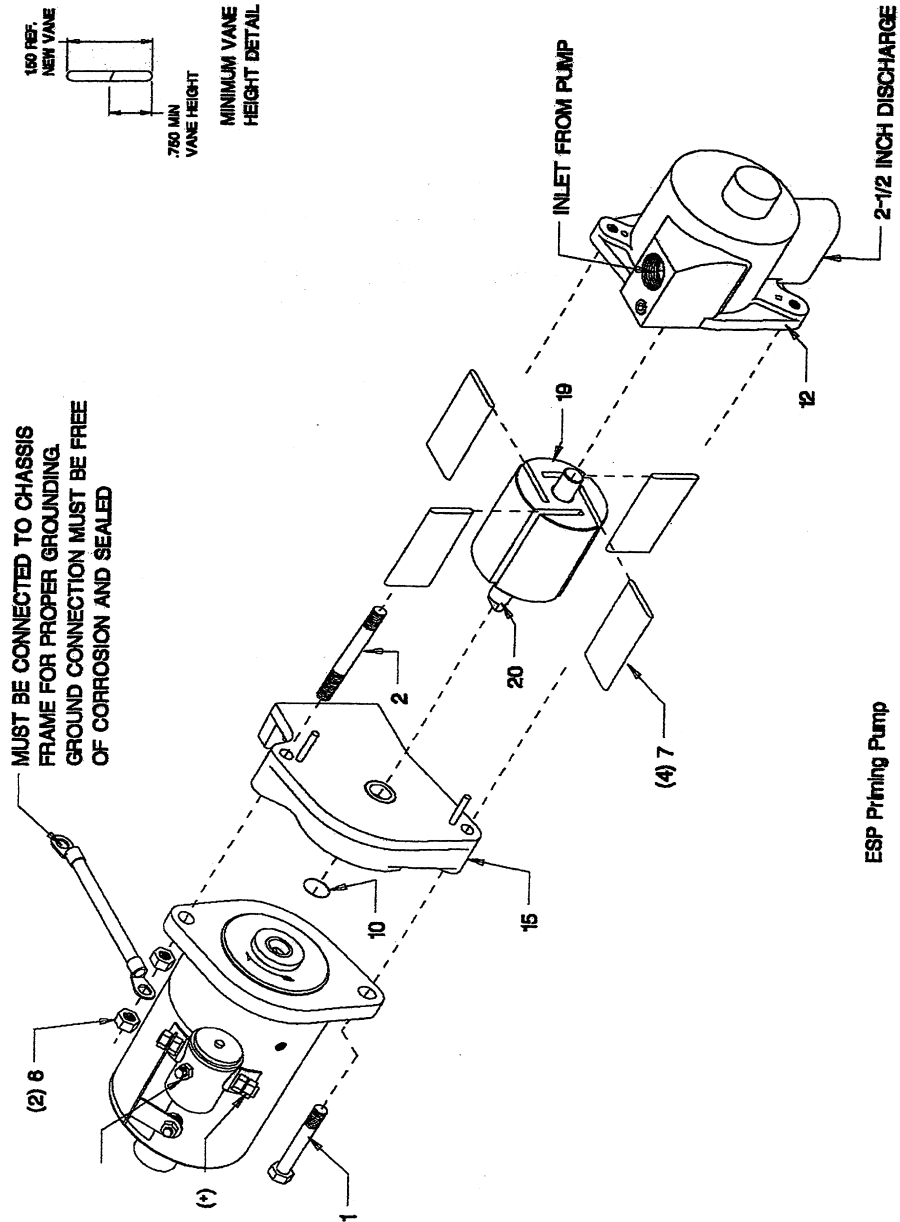

The Hale ESP primer is relatively maintenance free. If, after testing of the priming system, the primer fails to pull the required vacuum, the primer vanes may be worn and require replacement.



The following procedures should be used to replace the primer vanes.

1. Place apparatus out of service in accordance with departmental procedures.
2. De-energize apparatus electrical system.

NOTE: Before beginning disassembly, make note of the position and locations of components to ensure correct reassembly.

3. Tag and disconnect wires from battery connection, solenoid connection, and ground connection point.
4. Tag and disconnect hose from suction connection.
5. Loosen nuts on studs or bolts that hold primer assembly to mounting pad. Remove primer to suitable work area.
6. Remove the 3/8-16 UNC x 2-1/2 inch-long capscrew and remove the 3/8-16 UNC nut from stud. Carefully separate pump assembly from motor.
7. Using a nonmarring mallet, carefully separate the pump head from the pump body.
8. Mark the location of each primer vane. Remove the shaft and rotor assembly and the vanes from the pump body.
9. Remove the seal from the pump head assembly.
10. Inspect all components for corrosion and abnormal wear. Clean all components using Safety Kleen(TM) or Stoddard Solvent. Obtain new components as necessary.
11. Carefully press new seal into the pump head assembly.
12. Insert rotor and shaft assembly into pump body assembly. Slide new vanes into the slots in the rotor. Rotate the rotor and shaft making sure the vanes move freely in the slots.
13. If necessary, install new pins into the pump head assembly. Align the pins with the holes in the pump body assembly and slide pump head over rotor shaft. Once head is seated against the pump body, make sure the rotor assembly turns freely in the pump assembly.

 **Maintenance**

14. Install motor on pump assembly and secure in place using 3/8-16 UNC x 2-1/2 inch-long capscrew and 3/8-16 UNC nut on the stud. Tighten the nut and capscrew.
15. Place primer assembly on the mounting point and tighten capscrews or nuts.
16. Reconnect suction hose making sure the connection is tight.
17. Reconnect ground wire, battery connection, and solenoid connection.
18. Energize apparatus electrical system.
19. Test operate the primer to ensure it is working correctly.
20. Return apparatus to normal operation



Trident Primer Air Switch Connections

Service Bulletin

Trident Emergency Products, LLC
2940 Turnpike Drive, Suite 9
Hatboro, PA 19040



Subject: PRIMER AIR SWITCH CONNECTIONS	Bulletin No: 002
	Issue Date: 31March2008

APPLICABLE PRODUCTS

All Trident AirPrime Models controlled with panel mounted air push-button switch. We are advising all customers to visually double-check the air switch **air-in** and **air-out** connections for proper orientation, and switch them if they are incorrect. The switch will initially work either way, but will be more reliable over time when connected the proper way.

DESCRIPTION

The push-button panel air switch is spring-loaded and should move back out to the “closed” position after the operating force to push it is removed. We have seen some switches that do not consistently return to the “closed” position after the push-button is released. This has been due to the way the switch was plumbed when installed. The installation instructions now clearly show which holes in the switch should be used for **air-in** and **air-out** as well as the hole that is permanently plugged. If the switch is connected as shown below the air-in pressure will actually help the spring move the push-button back to the “closed” position.

IDENTIFICATION OF PROPER CONNECTIONS

The figure 1 below shows the **PROPER** connections for the panel mounted air push-button switch:

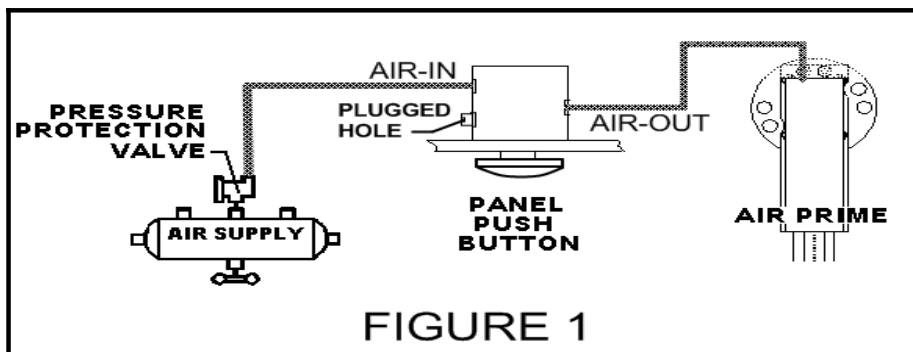

INSPECTION

Note that the air-switch has two connections on one side and one connection on the other. Check to see that the hole closer to the panel on the side with two connections is **PLUGGED**. Then check to see that the second hole on that side is coming from the air supply, or **AIR-IN**. Finally the connection on the side with one hole should be to the AirPrime which is **AIR-OUT** of the switch.

REPAIR

If the connections are as shown in the figure and INSPECTION paragraph above, no repair is required as the connections are correct. If the connections are not correct, they should be changed to correspond to the Figure 1 orientation which will increase the long term reliability of the air-switch operation.

NOTICE: The information and instructions in this bulletin are intended for use by skilled technicians. All customers should not assume this bulletin applies to their equipment and will develop the described concern.

Trident Air Prime

Airprime Operation

The Manual Air Prime is operated simply by increasing the engine speed to a maximum of 1000 rpm and depressing the push button on the panel. Hold the button down until the discharge pressure gauge begins to rise. The primer will stop running when the push button is released. Never run a dry pump at engine speeds above 1000 rpm.



Operational (Ramp) Test

The Air Prime integrity and operation can be quickly checked (on a daily or weekly basis) as outlined below:

1. Close all valves, and drains. Cap all suction openings and the outlet of the suction side relief valve (if so equipped).
2. Start the Air Prime with the air tanks fully charged, and the engine running at idle.
3. Verify that the reading on the pump intake gauge reaches an operational vacuum of at least 15 in.-Hg.
4. Stop running the primer.

Annual Priming Tests

There are two tests that should be performed at least on an annual basis, or whenever major repairs or modifications have been made to the pump or plumbing. They are the “Dry Vacuum Test”, and the “NFPA Priming Time Test”.

The **Dry Vacuum Test** checks the primer's ability to produce a 22in.-Hg vacuum, and the pump and plumbing's ability to hold that vacuum.

1. Close all valves and drains. Cap all suction openings and the outlet of the suction side relief valve (if so equipped).



4.11 Hale Midship Pump Maintenance Checklist

Truck Manufacturer _____

Pump Model & Serial Number _____

Year _____ Unit# _____

Recommended Weekly Procedures

- Test relief valve system or governor at 150, 200, 250 psi. If pump is equipped with TPM, you will need to have positive pressure.
- Operate transfer valve and check clapper valves for proper operation on two stage pumps.
- Test the priming system and check lubrication level in priming tank (if applicable).
- Operate all valves, discharge, suction, hose, drain, and multidrain.
- Check pump shift indicator lights.

Recommended Monthly Procedures	Jan	Feb	Mar	Apr	May	June	July	Aug	Sept	Oct	Nov	Dec
Complete weekly checks												
Lubricate threads on PM relief valve panel control and check light. DO NOT USE GREASE												
Lubricate remote valve controls and all valves												
Check controlled drip rate and adjust if necessary (8-10 drops per minute @ 100-150 psi)												
Perform dry vacuum test*												
check drive flange bolts to ensure tightness. Lubricate U-joint.												
Lubricate suction tube threads. DO NOT USE EXCESSIVE GREASE.												
Clean and inspect inlet strainers (Examine for loss of zinc)												
Inspect cap gaskets. Replace if cracked or damaged.												
Check oil level in pump gearbox; add oil as necessary or replace oil with SAE EP 90 oil if contamination is found.												

*Per NFPA-1911, para. 3-32, 22 inches minimum vacuum; loss not to exceed 10 inches vacuum in 5 minutes

 **Maintenance**

Recommended Annual Procedures

- Complete all previous checks.
- Check gauge calibration.
- Check oil level in AutoLube assembly (SEA-EP 90 oil). Pump must be drained of water prior to checking oil. See operation and maintenance manual for details.
- Lubricate power transfer cylinder, VPS shift cylinder, and shift control valve with air tool oil.
- Drain pump gearbox oil and refill (use SAE-EP 90 oil). Examine magnetic plug.
- Check individual drain lines from pump to multidrain to ensure proper drainage and protection from freezing.
- Lubricate transfer valve mechanism on two-stage pump. Dry molyspray is preferred.
- Perform yearly standard pump test (per NFPA-1911) to test pump performance levels.
- Repacking of pump is recommended every two or three years.
- Service ESP primer as per bulletin
- Remove and clean relief valve strainers

NOTE: The above general recommendations are provided for normal use and conditions. Extreme conditions or variables may indicate a need for increased maintenance. Good preventive maintenance lengthens pump life and ensures greater dependability. Consult Service or Diagnostic Chart in Operator's Manual for detailed information.

Hale Products Inc., A unit of IDEX Corporation, 700 Spring Mill Avenue, Conshohocken, PA 19428 Tel: 610/825-6300 Fax: 610/825-6440 Bulletin 889, Rev 1 11/05, Copyright 2005, Hale Products Inc.



4.12 Pump Checklist

Pump					
1.	Operate pump, check pump panel engine gauges.	Rec Min.			
2.	Check pump for pressure operation.	Rec Min.			
3.	Check discharge relief or pressure governor operation.	Rec Min.			
4.	Check all pump drain valves.		Rec Min.		
5.	Check all discharge and intake valve operation.		Rec Min.		
6.	Check pump and tank for water leaks.		Rec Min.		
7.	Check all valve bleeder/drain operation.		Rec Min.		
8.	Check primer pump operation.			Rec Min.	
9.	Check system vacuum hold.			Rec Min.	
10.	Check water tank level indicator.	Rec Min.			
11.	Check primer oil level (if applicable).		Rec Min.		
12.	Check transfer valve operation (if equipped).			Rec Min.	
13.	Check booster reel operation (if equipped).		Rec Min.		
14.	Check all pump pressure gauge operation.	Rec Min.			
15.	Check all cooler valves.			Rec Min.	
16.	Check for oil leaks in pump area.	Rec Min.			
17.	Check oil level of pump transmission.			Rec Min.	
18.	Check hour meter operation (If equipped)	Rec Min.			
19.	Check operation of valve linkage.	Rec Min.			
20.	Check ball valves for leaks.		Rec Min.		
21.	Check drain valves.		Rec Min.		

4.13 Draining and Winterizing

Draining & Winterizing Trucks

It is critical, especially during the cold months, to exercise caution when it comes to leaving trucks outside, transporting trucks, or accepting trucks into our possession. Anyone who gets behind the wheel of a truck is responsible for ensuring the truck is properly drained and stored.

Sutphen Guidelines for Draining and Winterizing Trucks

1. Communicate to all that water and foam tanks must be emptied prior to dropping any truck off to Sutphen for service.
2. Drain all trucks left outside completely, including water tanks, pumps, gauges and valves.
3. Ensure all valves (outboard and inline) are open 50% to drain trapped water.
 - Use caution if valve appears to be frozen in place; do not force a valve open or closed. Trucks may need warmed-up prior to operating frozen valves.
4. Run “RV antifreeze” through the foam pump and systems immediately after foam testing (approx. 3 gal.) from October through April.
5. Any truck being “Road Tested” needs to have all valves and drains open 50% to drain any trapped water. After road testing, the tank fill needs to be opened 100% to allow draining back into the pump. Ensure tank fill is turned back to 50% open after tank has fully drained back into the pump.

Please ensure everyone is fully aware of the expectations and follows the same guidelines. Thank you for your cooperation and dedication to avoiding costly repairs.



Chapter 5 Warranty

	<i>Page</i>
5.1 Sutphen Standard Vehicle Warranty	5-3

▼ **Warranty**

NOTES



5.1 Sutphen Standard Vehicle Warranty

Sutphen Corporation (Sutphen) warrants to the original purchaser (Purchaser) of a Sutphen vehicle that it will provide for repairs to the Sutphen vehicle during the warranty period in accordance with the following items, conditions, limitations, and exclusions.

1. **What is covered except as otherwise stated below:** Sutphen shall provide repair or replacement, at the sole option of Sutphen, of any part of a Sutphen vehicle in which a defect in materials or workmanship appears under normal use, maintenance, or service.

2. **Warranty Period:** This limited warranty is in effect for a period of twelve (12) months or 24,000 miles, whichever comes first. The warranty period will begin on the date the vehicle is delivered to the original purchaser. This limited warranty is void if the odometer has been disconnected, its reading has been altered, or true and accurate mileage cannot be otherwise determined by Sutphen.

3. **Other warranties:** The manufacturers of other equipment and components installed on the vehicle, including but not limited to engine, transmission, axles, pumps, signaling devices, and other installed equipment, may provide their own warranties. These warranties are separate from the Sutphen Limited Warranty and shall constitute the sole and exclusive warranty for those specifically covered components. Sutphen shall have no duty or obligation to repair or replace such components. Please review each manufacturer's warranty for descriptions and details of their respective warranty.

4. **Purchaser Responsibilities:** Normal maintenance, such as those detailed in the Sutphen Operation and Maintenance Manuals, are the responsibility of the Purchaser. Failure to comply with such maintenance voids this limited warranty.

5. **What is not covered:** This limited warranty covers only repair or replacement of any part of a Sutphen vehicle in which a defect in materials or workmanship appears within the limited warranty period. Examples of items not covered include, but not limited to:

A. Major components or trade accessories, such as purchased chassis, engines, signaling devices, batteries, tires, transmission, or generator that have a separate warranty by the original manufacturer or equipment used in fire fighting.

B. Unauthorized alteration or modification to the vehicle, including the body, chassis, or components, after completion of the vehicle assembly by Sutphen and any problems that occur as a result of such alterations or modifications. This includes but is not limited to aftermarket parts and accessories.

C. Damage caused by collision, fire, theft, freezing, vandalism, riot, explosion, acts of God, war, objects striking the vehicle or any damage covered by owner insurance.

 **Warranty**

D. Damage caused by misuse or improper operation of the vehicle, such as driving over curbs, overloading, racing, or off-road use.

E. Damage caused by failure to follow the requirements of the maintenance schedule, failure to maintain proper fluid and lubricant levels, and failure to follow operating instructions.

F. Normal maintenance, such as lubrication, filter replacement, fluid replacement, belts, hoses, clutch, brake linings, brake drums, disc brake rotors, and electric accessories, etc.

G. Batteries, tires, and light bulbs.

H. Towing charges and storage expenses.

I. Incidental expenses, such as loss of vehicle use, inconvenience, loss of time, vehicle rental, lodging or travel costs, and vacation pay, etc.

J. Discharge and compound gauges from freezing.

K. Leaking seals on discharge and suction valves.

L. Damage caused from exposure to road deicing compounds or use in an acidic environment.

M. Hydraulic failures caused by incorrect or contaminated oil.

N. This warranty terminates upon transfer of ownership of the vehicle from the original purchaser.

O. Damage caused from not following cab and body washing and care procedures located on truck and in Operation and Maintenance Manual.

6. Obtaining Repairs:

A. All limited warranty work must be authorized by Sutphen prior to repairs being attempted.

B. To obtain Limited Warranty Repairs, the vehicle must be taken by customer to an Authorized Sutphen Service Center within the limited warranty period. To find the name and location of the nearest Authorized Sutphen Vehicle Service Center in your area, call 1-800-726-7030 or 1-800-548-5860 or write Sutphen/Warranty Administration, 7000 Columbus-Marysville Rd., Amlin, OH 43002.

C. Sutphen reserves the right to inspect the vehicle before repairs are made and Sutphen shall be deemed the sole judge as to whether there is a defect in materials or workmanship under normal use, maintenance, or service.



D. Any part or parts considered to be covered by the conditions of this warranty shall be returned, freight prepaid, to the company's factory at Sutphen Corporation or to such other location as may be approved by the company. Replacement or repair of parts determined to be within the warranty shall be FOB at Sutphen Corporation.

E. In an emergency, where an Authorized Sutphen Corporation Service Center is not reasonably available, contact Sutphen Service Department for instructions. Repairs may be performed, at Purchaser's risk, at any available service establishment chosen by Purchaser. Purchaser must contact Sutphen Service Department the first business day after completion of repairs. Approved repair invoices must be received by Sutphen Corporation within sixty (60) days of repairs. Upon Sutphen's receipt of invoice, Sutphen will review the invoice for reimbursement to the Purchaser. Any reimbursement will consist only of the reasonable and customary repair expenses normally covered under the Sutphen Limited Warranty. Sutphen will assume no liability and will not warrant the workmanship or components which are the subject of any reimbursement under this policy.

7. Warranty Limitations:

A. Nothing contained in this warranty shall make SUTPHEN CORPORATION liable beyond the express limitations hereof for loss, injury, or damage of any kind to any person or entity resulting from any defect or failure in the machine.

B. To the extent permitted by law, this warranty is also in lieu of all other obligations or liabilities on the part of SUTPHEN CORPORATION or the seller, including liability for incidental and consequential damages.

C. SUTPHEN CORPORATION makes no representation that the machine has the capacity to perform any functions other than as contained in the company's written literature, catalogs, or specifications accompanying delivery of the machine.

D. No person or affiliated company representative is authorized to give any other warranties or to assume any other liability on behalf of SUTPHEN CORPORATION in connection with sale, service, or repair of any apparatus manufactured by the company.

E. SUTPHEN CORPORATION reserves the right to make design changes or improvements in its products without imposing any obligation upon itself to change or improve previously manufactured products.

 **Warranty**

THIS WARRANTY IS PROVIDED IN EXCLUSION OF ANY AND ALL OTHER REPRESENTATIONS, EITHER EXPRESSED OR IMPLIED. NO PERSON IS AUTHORIZED TO MAKE ANY REPRESENTATION OR WARRANTY ON BEHALF OF SUTPHEN CORPORATION OTHER THAN SET FORTH HEREIN. ANY MODIFICATION TO THIS WARRANTY MUST BE IN WRITING AND APPROVED BY THE PRESIDENT OF SUTPHEN CORPORATION. THE PROVISIONS OF THIS LIMITED WARRANTY SHALL CONSTITUTE THE SOLE AND EXCLUSIVE REMEDIES OF A SUTPHEN VEHICLE PURCHASER.

For more information contact:

Sutphen Corporation/Warranty Admin. • 935 S. Edgewood Avenue • Urbana, OH 43078

(614) 889-1005 • Toll Free (800) 726-7030 or (800)848-5860

