

HOSE BED  
300' OF 3"  
1200' OF 5"  
200' OF 2"  
200' OF 2"

LADDER CHUTE  
24'-2 SEC  
14' ROOF  
10' FOLDING  
8' FOLDING  
(1) STOKES STOR

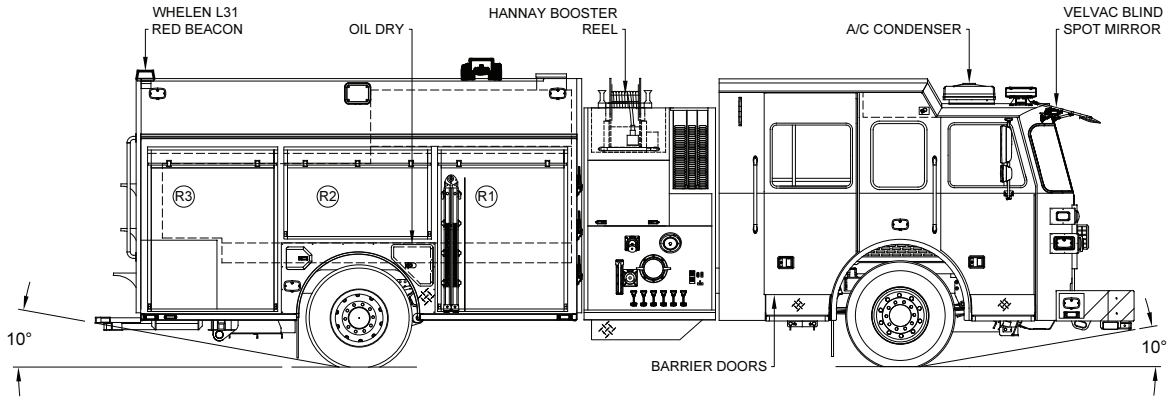

LEFT SIDE COMPARTMENTS				
COMPT	DOORS	OPENING DIMENSIONS	INSIDE DIMENSIONS	VOLUME
L1	ROLL-UP	50.5" w X 59.4" h	56.1" w X 70" h X 25.8" d	52.9 CU. FT. (11.5" h X 10.5" d UPPER)
L2	ROLL-UP	57.5" w X 30.2" h	61.6" w X 40.8" h X 25.8" d	37.5 CU. FT. (11.5" h X 10.5" d UPPER)
L3	ROLL-UP	50.5" w X 59.4" h	53.4" w X 70" h X 25.8" d	50.4 CU. FT. (11.5" h X 10.5" d UPPER)

RIGHT SIDE COMPARTMENTS				
COMPT	DOORS	OPENING DIMENSIONS	INSIDE DIMENSIONS	VOLUME
R1	ROLL-UP	50.5" w X 59.4" h	56.1" w X 70" h X 25.8" d	52.9 CU. FT. (11.5" h X 10.5" d UPPER)
R2	ROLL-UP	57.5" w X 30.2" h	61.6" w X 40.8" h X 25.8" d	37.5 CU. FT. (11.5" h X 10.5" d UPPER)
R3	ROLL-UP	50.5" w X 59.4" h	53.4" w X 70" h X 25.8" d	50.4 CU. FT. (11.5" h X 10.5" d UPPER)

REAR STEP COMPARTMENT				
COMPT	DOORS	OPENING DIMENSIONS	INSIDE DIMENSIONS	VOLUME
A1	ROLL-UP	40.5" w X 30.8" h	43" w X 28" h X 31" d	21.6 CU. FT.

TOTAL: 303.2 CU.FT.

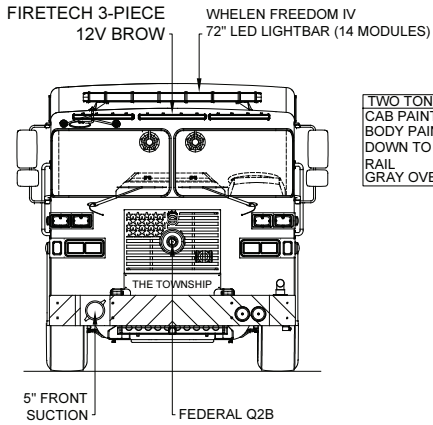
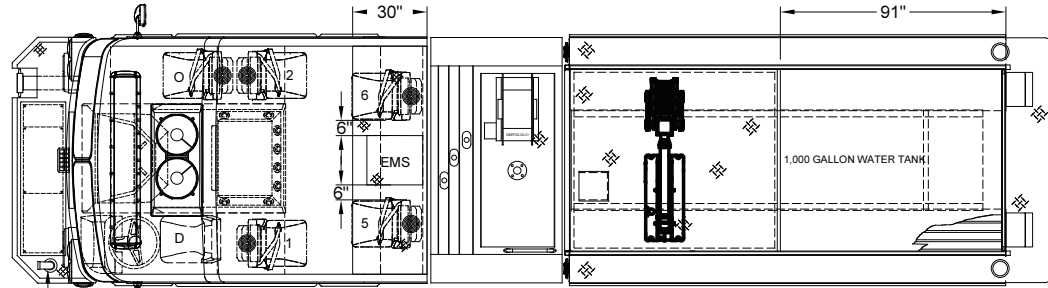

TWO TONE CAB & BODY  
CAB PAINT BREAK: #1  
BODY PAINT BREAK:  
DOWN TO BODY DRIP  
RAIL  
GRAY OVER RED

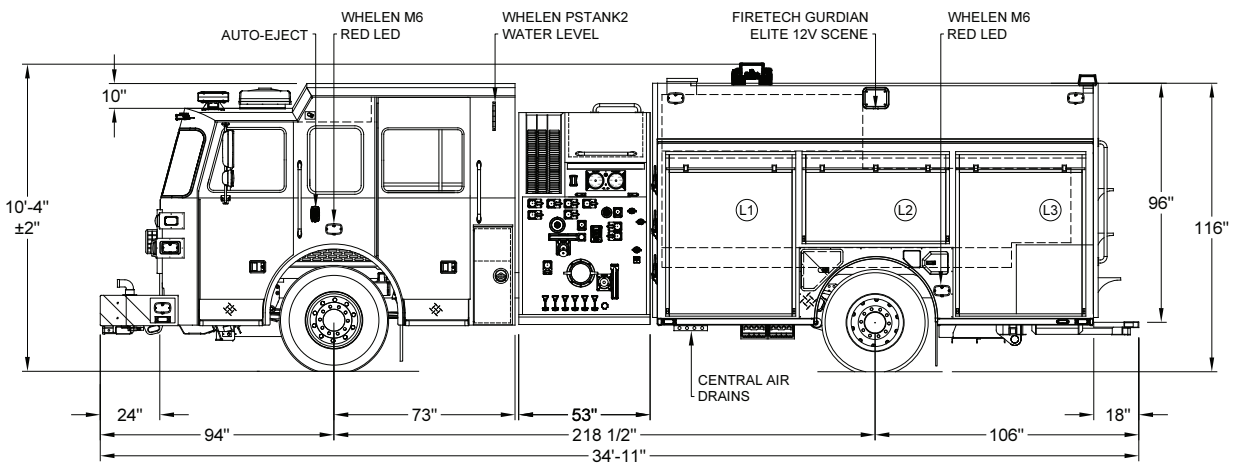

DIMENSIONS SHOWN ON THIS DRAWING ARE APPROXIMATE AND ARE SUBJECT TO MINOR DEVIATIONS DURING CONSTRUCTION.

IN THE EVENT OF A DISCREPANCY BETWEEN THE SUTPHEN SPECIFICATIONS AND DRAWING, THE SUTPHEN SPECIFICATIONS SHALL PREVAIL.

DRAWING IS FOR REFERENCE ONLY. SOME ITEMS PROPOSED MAY NOT BE SHOWN OR NOTED.

CUSTOMER APPROVAL

NAME: \_\_\_\_\_

TITLE: \_\_\_\_\_

DATE: \_\_\_\_\_

REV	DESCRIPTION	BY	DATE
N	POST-PRODUCTION SHOP ORDER	TF	11/07/23
M	REFERENCE SHOP ORDER CHANGE DOCUMENT ON SHARED DRIVE	TF	10/17/23
L	REFERENCE SHOP ORDER CHANGE DOCUMENT ON SHARED DRIVE	TF	08/28/23
K	REFERENCE SHOP ORDER CHANGE DOCUMENT ON SHARED DRIVE	TF	07/07/23

DATE: 07/02/21

DRAWN BY: T.FAHOUM

MFG. FACILITY: DUBLIN

DWG. NO.:

CUSTOM PUMPER - PA-19  
HS-7183

CENTER TOWNSHIP VOL. FIRE DEPARTMENT  
ALIQUIPPA, PA

THIS PRINT IS PROVIDED ON A RESTRICTED BASIS AND IS NOT TO BE USED IN ANY WAY DETRIMENTAL TO THE INTEREST OF SUTPHEN CORPORATION.