

LEFT SIDE COMPARTMENTS				
COMPT	DOORS	OPENING DIMENSIONS	INSIDE DIMENSIONS	VOLUME
L1	HINGE	33.5" W X 55.4" H	43.1" W X 66" H X 27.3" D	40.8 CU. FT. (110" X 10.5" D UPPER)
L2	HINGE	53.5" W X 26.2" H	61.6" W X 36.8" H X 27.3" D	29.8 CU. FT. (110" X 10.5" D UPPER)
L3	HINGE	46.5" W X 55.4" H	53.4" W X 66" H X 27.3" D	50.5 CU. FT. (110" X 10.5" D UPPER)

RIGHT SIDE COMPARTMENTS				
COMPT	DOORS	OPENING DIMENSIONS	INSIDE DIMENSIONS	VOLUME
R1	HINGE	33.5" W X 55.4" H	43.1" W X 66" H X 27.3" D	31.1 CU. FT. (33" H X 10.5" D UPPER)
R2	HINGE	53.5" W X 26.2" H	61.6" W X 36.8" H X 10.5" D	13.8 CU. FT.
R3	HINGE	46.5" W X 55.4" H	53.4" W X 66" H X 27.3" D	38.6 CU. FT. (33" H X 10.5" D UPPER)

REAR STEP COMPARTMENT				
COMPT	DOORS	OPENING DIMENSIONS	INSIDE DIMENSIONS	VOLUME
A1	ROLL-UP	37.5" W X 30.8" H	40" W X 40" W X 31" D	28.7 CU. FT.
HALE QMAX-1500 GPM SINGLE STAGE, 1000 GAL WATER TANK				TOTAL: 233.3 CU.FT.

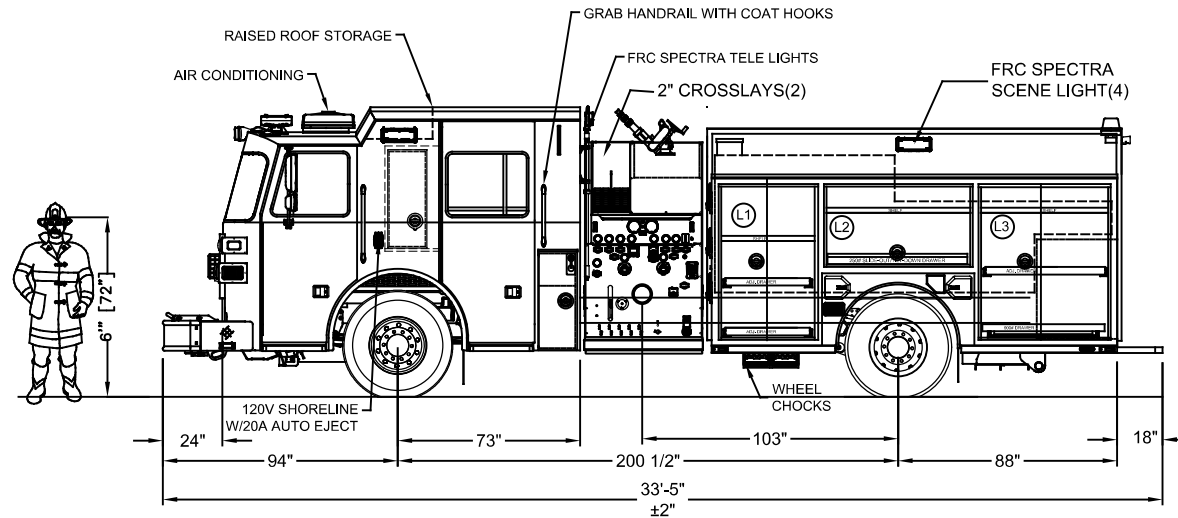
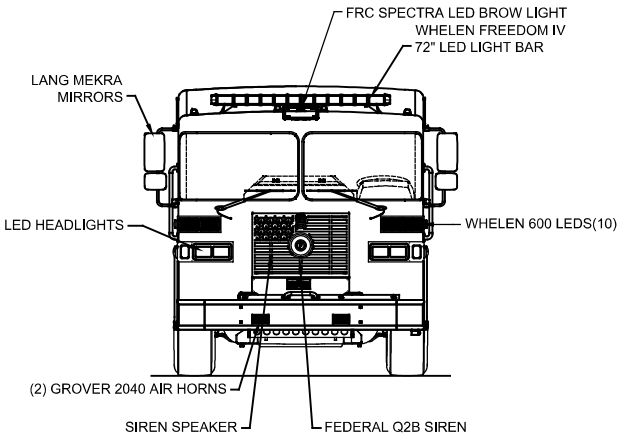
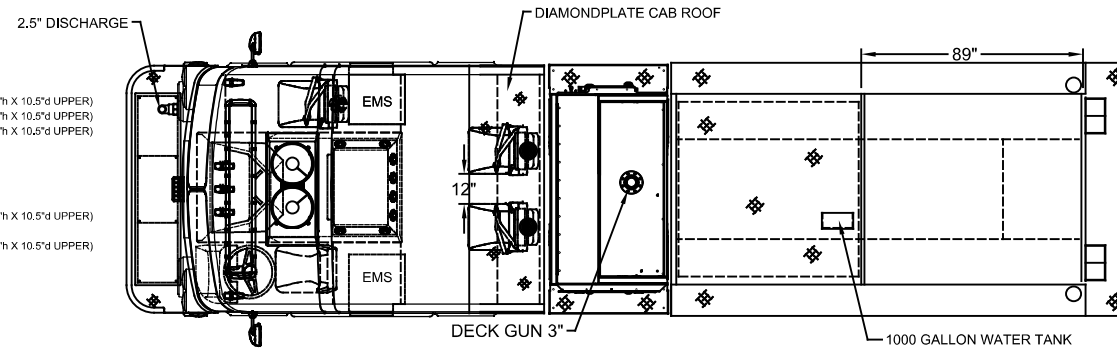

DIMENSIONS SHOWN ON THIS DRAWING ARE APPROXIMATE AND ARE SUBJECT TO MINOR DEVIATIONS DURING CONSTRUCTION.

IN THE EVENT OF A DISCREPANCY BETWEEN THE SUTPHEN SPECIFICATIONS AND DRAWING, THE SUTPHEN SPECIFICATIONS SHALL PREVAIL.

DRAWING IS FOR REFERENCE ONLY. SOME ITEMS PROPOSED MAY NOT BE SHOWN OR NOTED.

CUSTOMER APPROVAL

NAME: \_\_\_\_\_

TITLE: \_\_\_\_\_

DATE: \_\_\_\_\_

REV.	DESCRIPTION	BY	DATE
REV E	CHANGE ORDER E (SHELVING)	SD	2-1-22
REV C	CHANGE TOP SPEED/ AXLE RATING	SD	12-15-22
REV B	GRPHICS	SD	09-24-22
REV A	PRE-CON	SD	02-4-22

DRAWN BY:  
S.DORFMAN

DATE:  
06/15/21

INFO. FACILITY:  
SUTPHEN EAST  
LAKE ARIEL, PA

GLOVERSVILLE FIRE DEPARTMENT  
GLOVERSVILLE, NY

PROGRAM 2 PUMPER - S2-SS

THIS PRINT IS PROVIDED ON A RESTRICTED BASIS AND IS NOT TO BE USED IN ANY WAY DETRIMENTAL TO THE INTEREST OF SUTPHEN CORPORATION.

FIG. NO.: HS-####