

| Left Side Compartmentation  |       |                    |                   |            |
|-----------------------------|-------|--------------------|-------------------|------------|
| Compt                       | Doors | Opening Dimensions | Inside Dimensions | Volume     |
| L1                          | HINGE | 49x67              | 56x72x24.25/10.25 | 42 CU FT   |
| L2                          | HINGE | 50x29              | 56x34x10.25       | 10.6 CU FT |
| L3                          | HINGE | 50x29              | 56x34x10.25       | 10.6 CU FT |
| L4                          | HINGE | 46x67              | 53x72x24.25/10.25 | 39.8 CU FT |
| Right Side Compartmentation |       |                    |                   |            |
| Compt                       | Doors | Opening Dimensions | Inside Dimensions | Volume     |
| R1                          | HINGE | 49x67              | 56x72x24.25/10.25 | 42 CU FT   |
| R2                          | HINGE | 50x29              | 56x34x10.25       | 10.6 CU FT |
| R3                          | HINGE | 50x29              | 56x34x10.25       | 10.6 CU FT |
| R4                          | HINGE | 46x67              | 53x72x24.25/10.25 | 39.8 CU FT |
| Total Volume                |       |                    |                   | 208 CU Ft  |

HALE QMAX-2000 GPM  
2500 GALLONS OF WATER

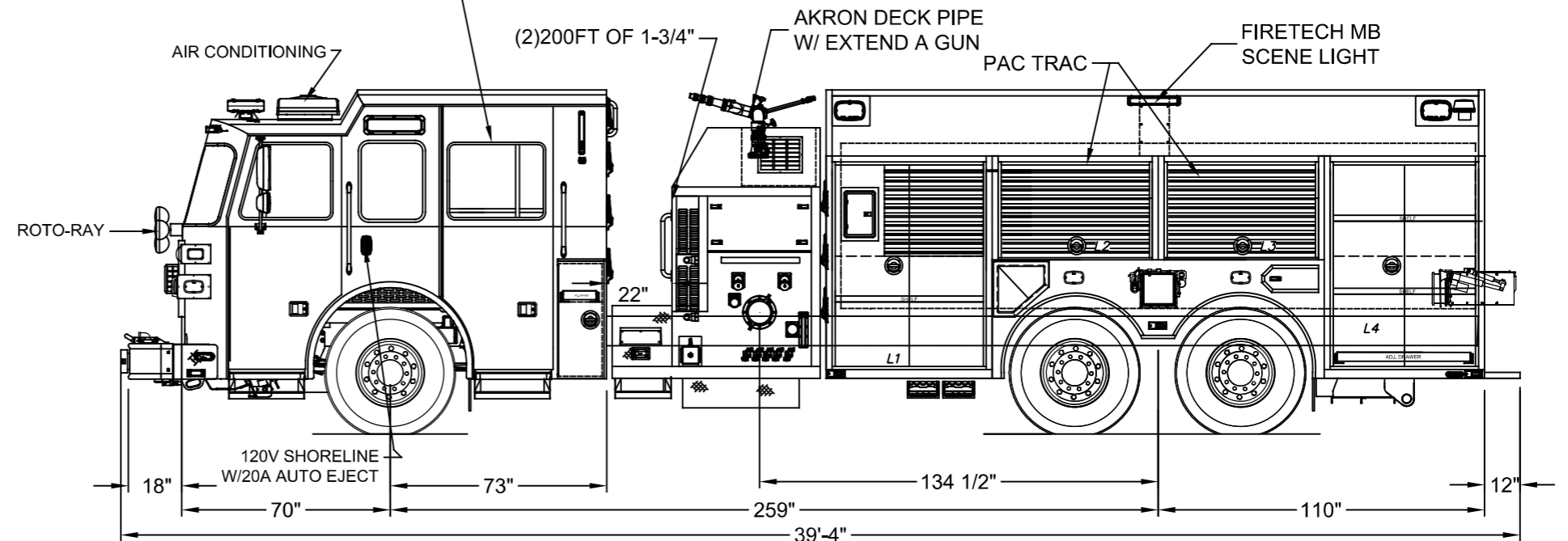
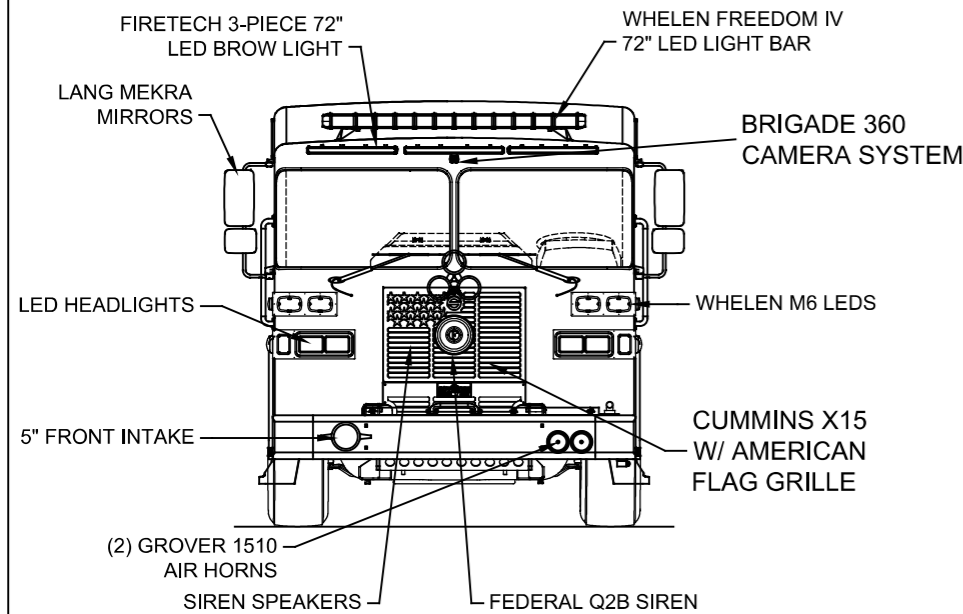
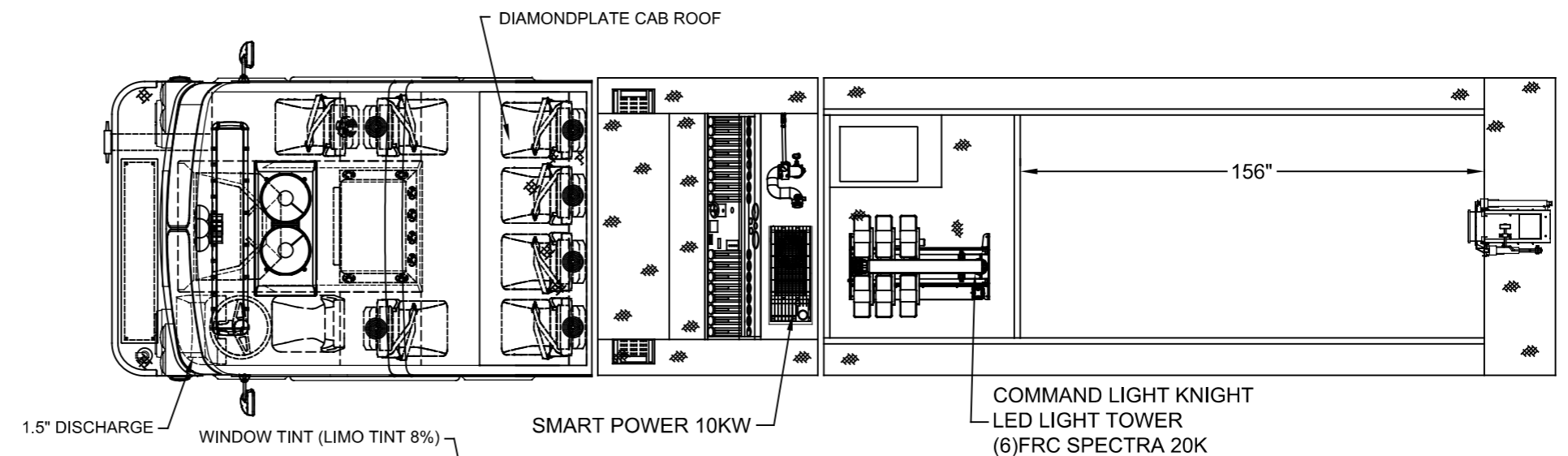

DIMENSIONS SHOWN ON THIS DRAWING ARE APPROXIMATE AND ARE SUBJECT TO MINOR DEVIATIONS DURING CONSTRUCTION.  
IN THE EVENT OF A DISCREPANCY BETWEEN THE SUTPHEN SPECIFICATIONS AND DRAWING, THE SUTPHEN SPECIFICATIONS SHALL PREVAIL.  
DRAWING IS FOR REFERENCE ONLY. SOME ITEMS PROPOSED MAY NOT BE SHOWN OR NOTED.

CUSTOMER APPROVAL

NAME: \_\_\_\_\_  
TITLE: \_\_\_\_\_  
DATE: \_\_\_\_\_

|         |  |    |         |
|---------|--|----|---------|
| REV C-D | AUX STEPS AND SHELIVING                            | RR | 11/9/22 |
| REV B   | CHANGE TO ELECTRIC SIREN AND ADD HEAD SET INTERCOM | SD | 6/6/21  |
| REV A   | CHANGES FROM PRE-CON                               | SD | 8/16/21 |

THIS PRINT IS PROVIDED ON A RESTRICTED BASIS AND IS NOT TO BE USED IN ANY WAY DETRIMENTAL TO THE INTEREST OF SUTPHEN CORPORATION.

DRAWN BY:  
S.DORFMAN  
DATE:  
6/15/21  
MFG. FACILITY:  
EAST

LUMERLAND FIRE DISTRICT  
GLEN SPEY, NY  
CUSTOM STAINLESS TANKER  
DWG. NO.: HS-7111