

Left Side Compartmentation				
Compt	Doors	Opening Dimensions	Inside Dimensions	Volume
			WxHxD	
L1	Roll Up	28x29	35x39x24.25	17.7 CU FT
L2	Roll Up	43x29	50x39x24.25	25.3 CU FT
L3	Roll Up	23x29	30x39x24.25	15.2 CU FT
Right Side Compartmentation				
Compt	Doors	Opening Dimensions	Inside Dimensions	Volume
R1	Roll Up	28x29	35x39x24.25	17.7 CU FT
R2	Roll Up	43x29	50x39x24.25	25.3 CU FT
R3	Roll Up	23x29	30x39x24.25	15.2 CU FT
Total Volume				116.2 CU Ft

Hale QMAX 1500 single stage
Water Tank Capacity 3000 gal

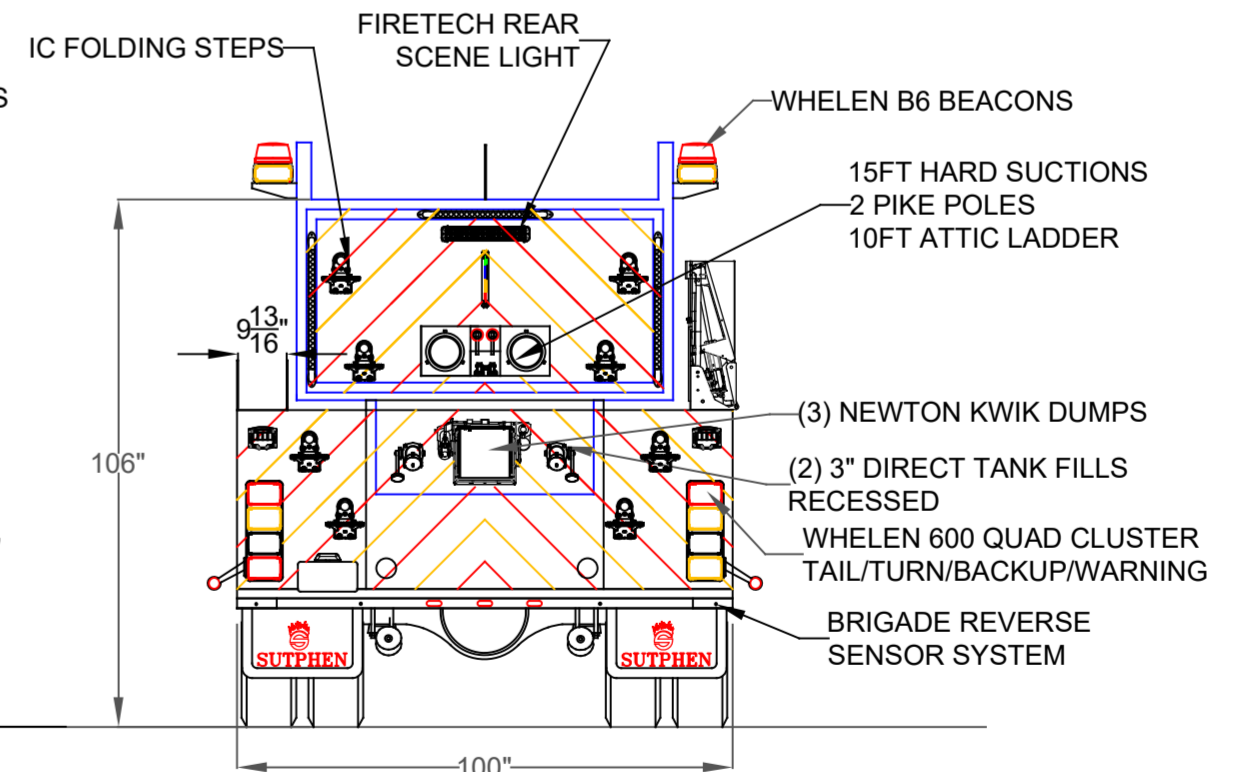
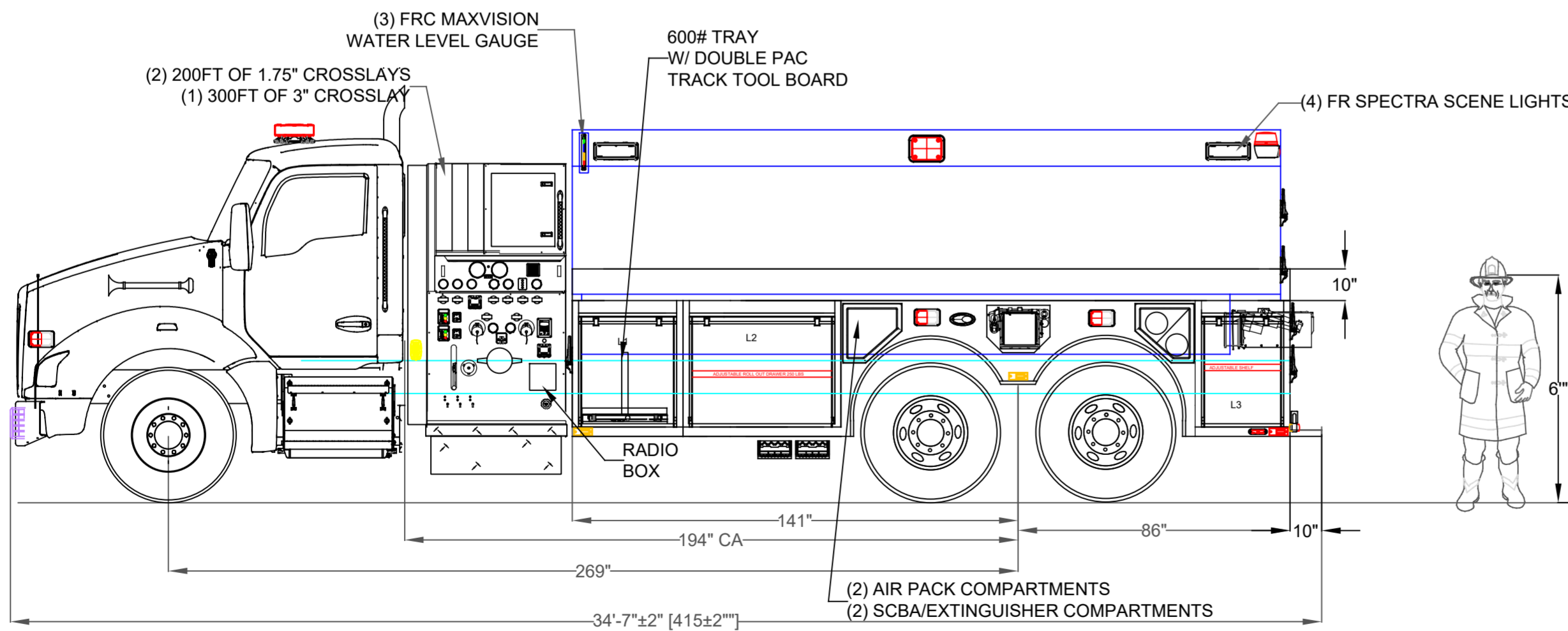

DIMENSIONS SHOWN ON THIS DRAWING ARE APPROXIMATE AND ARE SUBJECT TO MINOR DEVIATIONS DURING CONSTRUCTION.

IN THE EVENT OF A DISCREPANCY BETWEEN THE SUTPHEN SPECIFICATIONS AND DRAWING, THE SUTPHEN SPECIFICATIONS SHALL PREVAIL.

DRAWING IS FOR REFERENCE ONLY. SOME ITEMS PROPOSED MAY NOT BE SHOWN OR NOTED.

CUSTOMER APPROVAL

NAME: _____

TITLE: _____

DATE: _____

REV.	DESCRIPTION	BY	DATE
D	CHANGES FROM CHANGE ORDER REV D	SED	5-17-22
C	CHANGES FROM CHANGE ORDER REV C	SED	5-17-22
B	CHANGES FROM CHANGE ORDER REV B	SED	6-1-21
A	CHANGES FROM PRE-CON	SED	5-17-21

THIS PRINT IS PROVIDED ON A RESTRICTED BASIS AND IS NOT TO BE USED IN ANY WAY DETRIMENTAL TO THE INTEREST OF SUTPHEN CORPORATION.

DRAWN BY: S.DORFMAN

DATE: 11/25/20

MFG. FACILITY: SUTPHEN EAST LAKE ARIEL, PA

SUTPHEN

NEWPORT FIRE DEPARTMENT
NEWPORT, PA

SWT-04B Commercial Wetside Tanker

DWG. NO.: