

Left Side Compartmentation				
Compt	Doors	Opening Dimensions	Inside Dimensions	Volume
WxHxD				
L1	Hinged	28x59	35x66x24.25/10.25	24.2 CU FT
L2	Hinged	49x22	56x29x10.25	9.6 CU FT
L3	Hinged	49x22	56x29x10.25	9.6 CU FT
L3	Hinged	33x59	40x66x24.25/10.25	26.0 CU FT
Right Side Compartmentation				
Compt	Doors	Opening Dimensions	Inside Dimensions	Volume
R1	Hinged	28x49	35x59x24.25	22.9 CU FT
R2	Hinged	49x18	56x23x10.25	7.6 CU FT
R3	Hinged	49x18	56x23x10.25	7.6 CU FT
R4	Hinged	33x49	40x59x24.25	25.7 CU FT
Total Volume				133.2 CU FT

Hale Qmax 2000 single stage
Water Tank Capacity 2500 gal

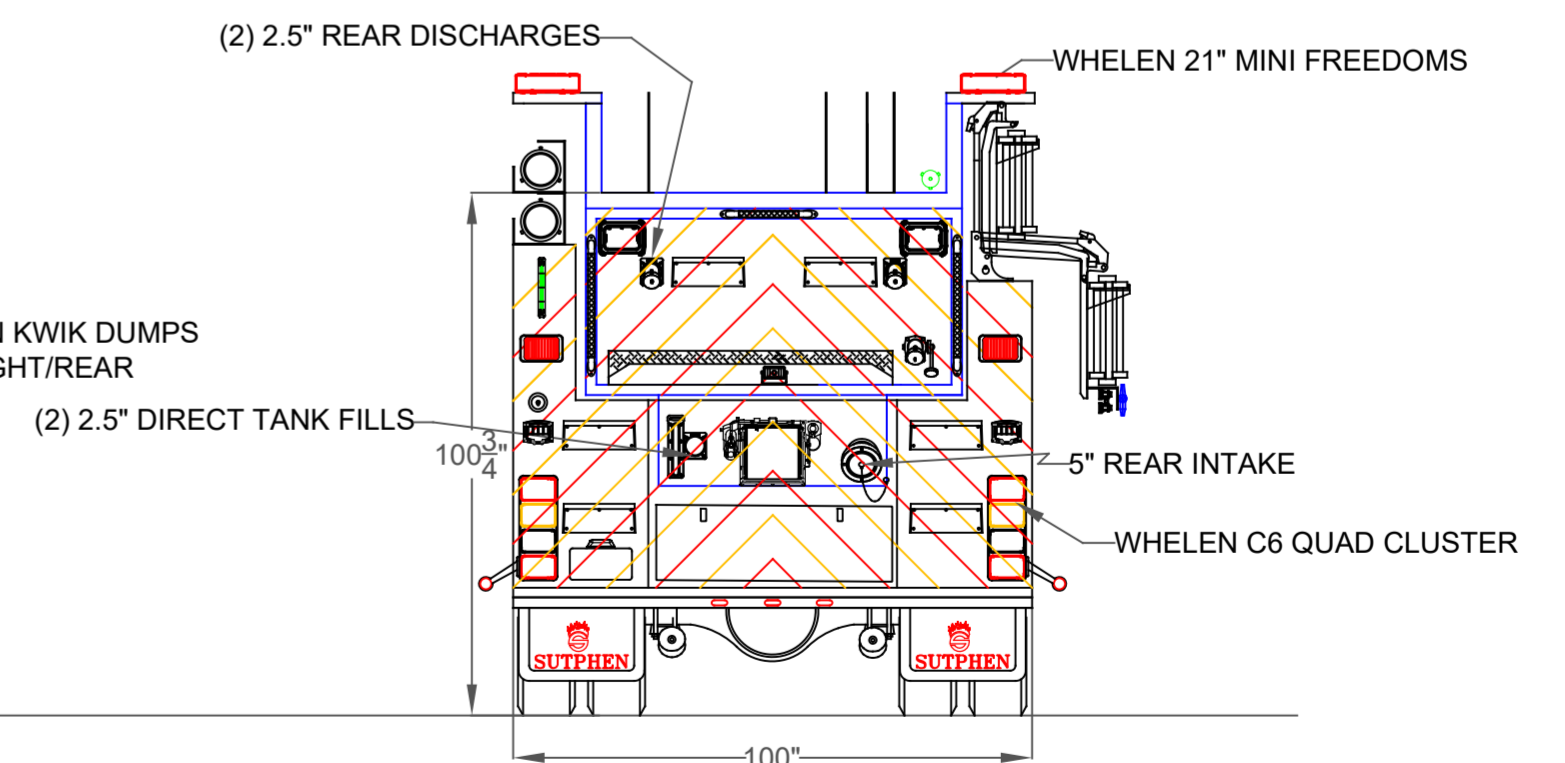
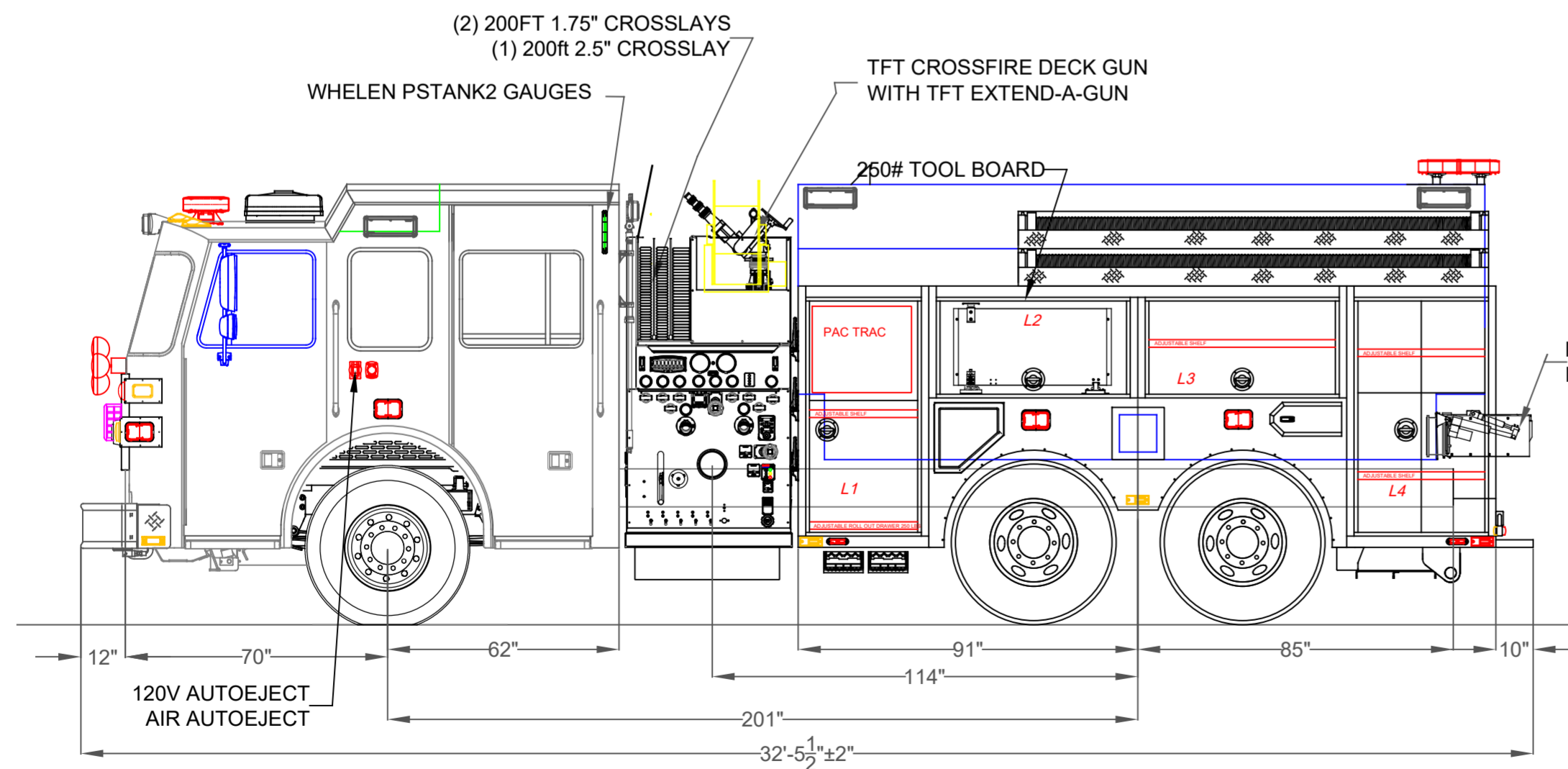

DIMENSIONS SHOWN ON THIS DRAWING ARE APPROXIMATE AND ARE SUBJECT TO MINOR DEVIATIONS DURING CONSTRUCTION.

IN THE EVENT OF A DISCREPANCY BETWEEN THE SUTPHEN SPECIFICATIONS AND DRAWING, THE SUTPHEN SPECIFICATIONS SHALL PREVAIL.

DRAWING IS FOR REFERENCE ONLY. SOME ITEMS PROPOSED MAY NOT BE SHOWN OR NOTED.

CUSTOMER APPROVAL

NAME: _____

TITLE: _____

DATE: _____

REV.	DESCRIPTION	BY	DATE
D	CHANGES TO GRAPHICS, #3 DISCHARGE TO BE ELECTRIC ACTUATOR, TRIDENT HAND WHEEL FOR DECK GUN, TANK TO PUMP	RR	1/18/2022
C	ELECTRIC ACTUATOR FOR RIGHT REAR DISCHARGE	SED	1/3/2022
B	ADD HOSE BED DIVIDER, FOOT SWITCH FOR MECH SIREN	SED	7/12/2021
A	CHANGES FROM PRE-CON	SED	7/10/2021

THIS PRINT IS PROVIDED ON A RESTRICTED BASIS AND IS NOT TO BE USED IN ANY WAY DETRIMENTAL TO THE INTEREST OF SUTPHEN CORPORATION.

DRAWN BY: S.DORFMAN

DATE: 04/01/2021

MFG. FACILITY: SUTPHEN EAST LAKE ARIEL, PA

SUTPHEN EAST
55 INNOVATION DRIVE
LAKE ARIEL, PA
1-844-776-2889

MT. SOLON VOLUNTEER FIRE RESCUE
MT. SOLON, VA

CUSTOM STS WETSIDE TANKER

DWG. NO.: HS 7059