

- LADDER CHUTE**
- (1) 14' COMBO
 - (1) 24' 2-SEC
 - (2) 16' ROOF
 - (1) 10' FOLDING
 - (1) 35' 2-SEC

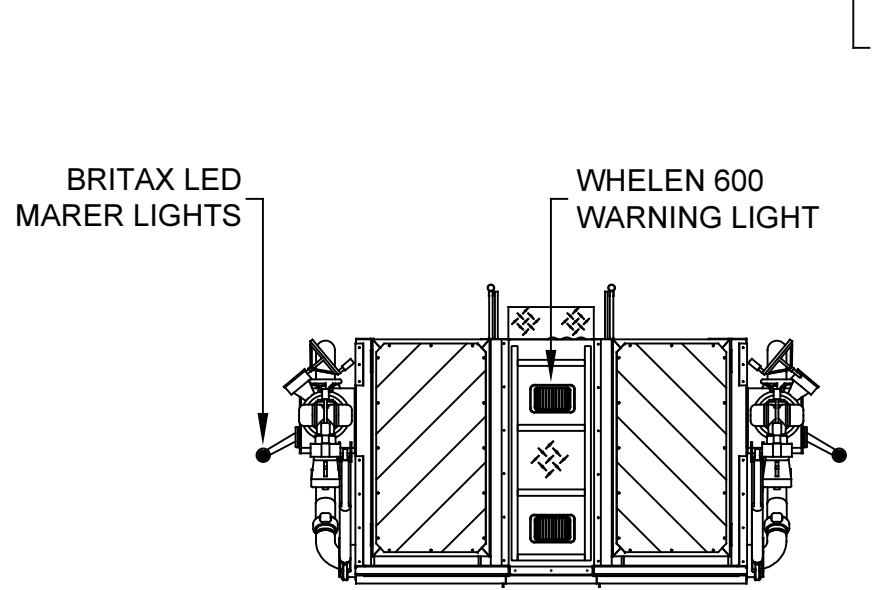

TWO TONE CAB
WHITE OVER RED
PAINT BREAK #1

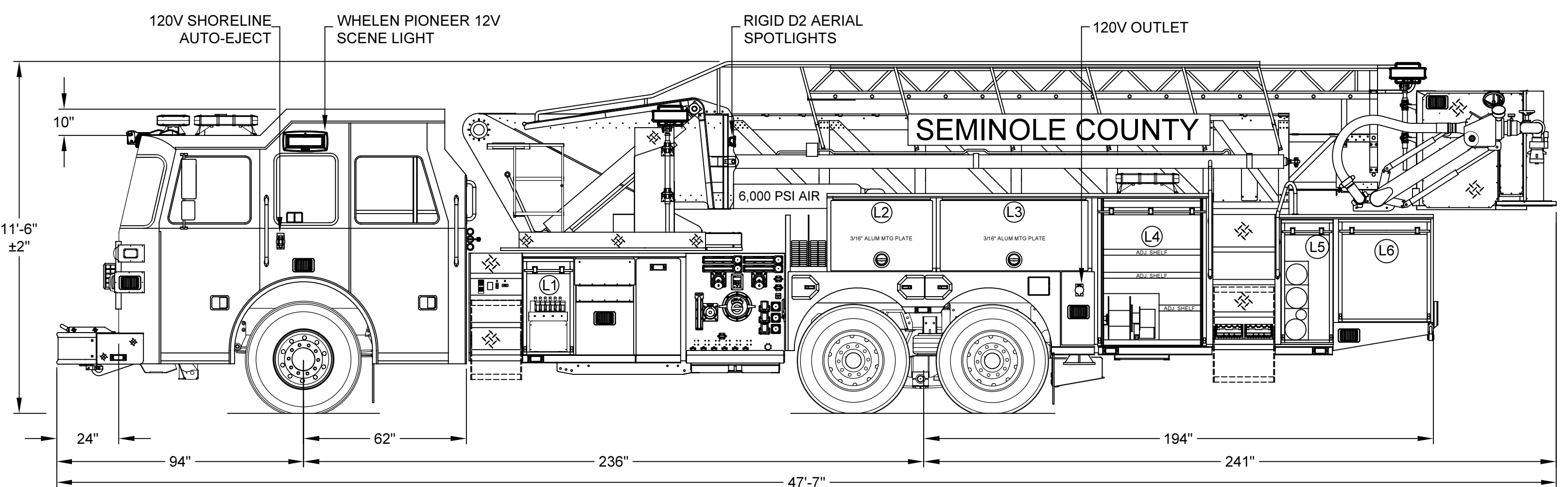
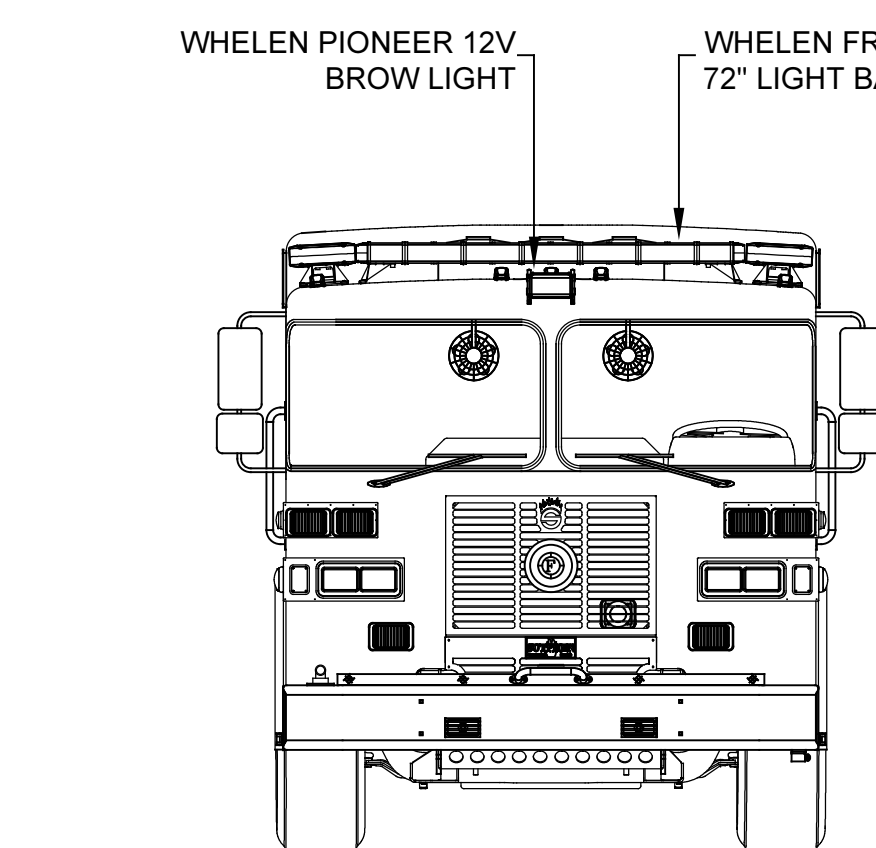
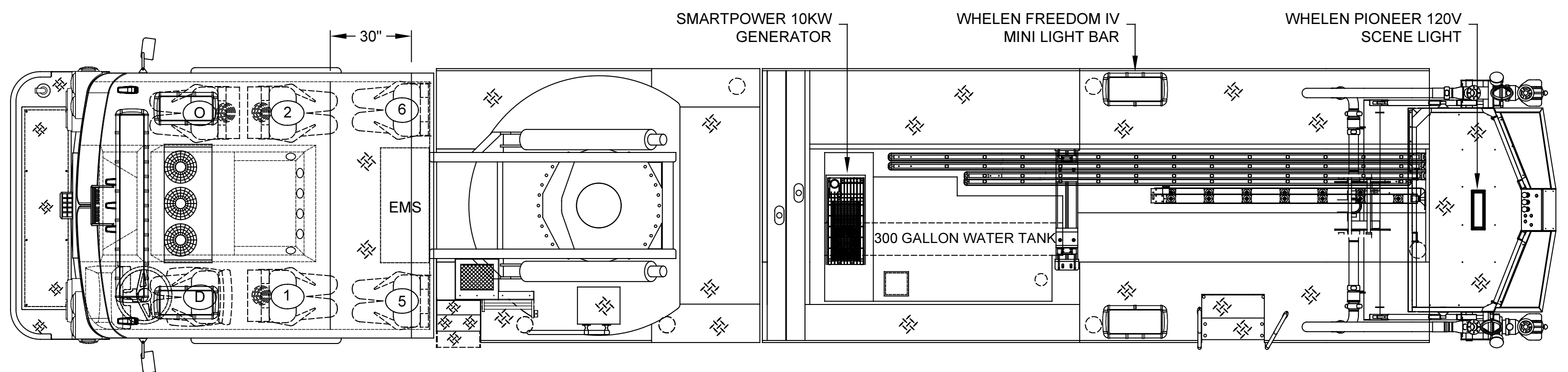

DOOR OPENINGS			COMPARTMENT DIMENSIONS		
COMP.T.	HEIGHT	WIDTH	HEIGHT	WIDTH	DEPTH
L1	31 1/2	13 1/2	38 1/2	20 1/4	20 1/4
L2	23	33 1/4	27 1/2	41 1/2	12 1/8
L3	23	50 1/4	27 1/2	58	12 1/8
L4	48 1/2	38 3/4	56 1/2	45 3/4	26 1/2
L5	40 1/2	15 1/8	48 1/2	22	26 1/2
L6	32 1/8	30 7/8	40 1/8	34 3/4	26 1/2

DOOR OPENINGS			COMPARTMENT DIMENSIONS		
COMP.T.	HEIGHT	WIDTH	HEIGHT	WIDTH	DEPTH
R1	31 1/2	33 1/2	38 1/2	40	27 1/2
R2	23	33 1/4	27 1/2	41 1/2	26 1/2
R3	23	50 1/4	27 1/2	58	26 1/2
R4	48 1/2	38 3/4	56 1/2	45 3/4	26 1/2
R5	48 1/2	38 3/4	56 1/2	45 3/4	26 1/2
R6	32 1/8	30 7/8	40 1/8	34 3/4	26 1/2

TOTAL COMPARTMENT VOLUME- 293 CU FT.

DOOR OPENINGS			COMPARTMENT DIMENSIONS		
COMP.T.	HEIGHT	WIDTH	HEIGHT	WIDTH	DEPTH
A1	9 1/8	24 1/2	9 7/8	26	88

DIMENSIONS SHOWN ON THIS DRAWING ARE APPROXIMATE AND ARE SUBJECT TO MINOR DEVIATIONS DURING CONSTRUCTION.

IN THE EVENT OF A DISCREPANCY BETWEEN THE SUTPHEN SPECIFICATIONS AND DRAWING, THE SUTPHEN SPECIFICATIONS SHALL PREVAIL.

DRAWING IS FOR REFERENCE ONLY. SOME ITEMS PROPOSED MAY NOT BE SHOWN OR NOTED.

CUSTOMER APPROVAL

NAME: _____

TITLE: _____

DATE: _____

REV.	DESCRIPTION	BY	DATE
D	REV-D SHOP ORDER/REFERENCE SHOP ORDER DOCUMENT ON SHARED DRIVE	JML	02/17/2022
C	REV-C SHOP ORDER/REFERENCE SHOP ORDER DOCUMENT ON SHARED DRIVE	JML	10/26/2021
B	REV-B SHOP ORDER/REFERENCE SHOP ORDER DOCUMENT ON SHARED DRIVE	JML	07/19/2021
A	REV-A SHOP ORDER	JML	04/23/2021

DRAWN BY:	JLAMBERT
DATE:	01/25/2021
MFG. FACILITY:	DUBLIN

SUTPHEN

SEMINOLE COUNTY FIRE RESCUE
SANFORD, FL

SPH100 AERIAL PLATFORM

DWG. NO.: HS-7036