

TWO TONE CAB
WHITE OVER RED
PAINT BREAK #1

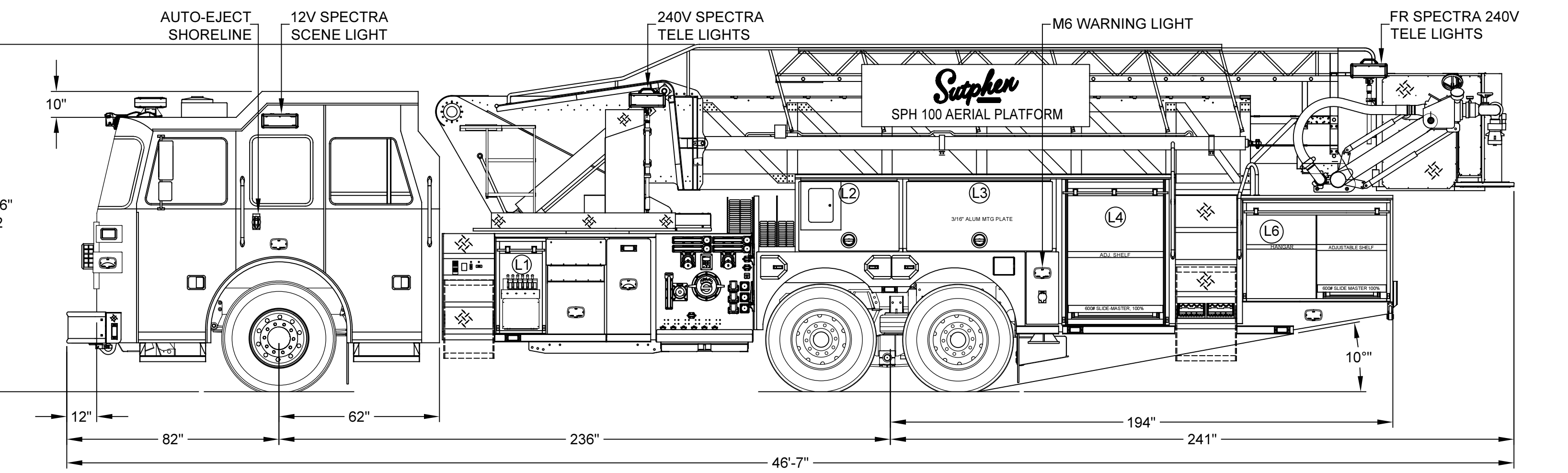
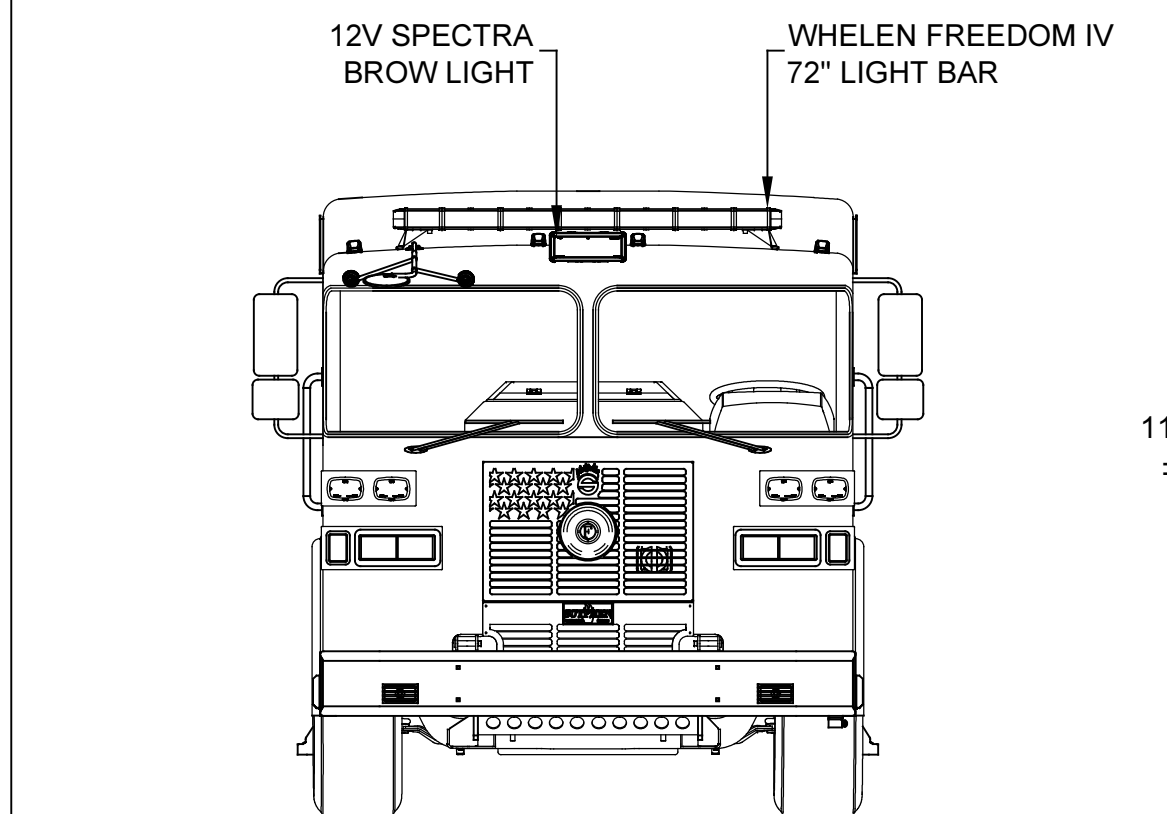

DOOR OPENINGS			COMPARTMENT DIMENSIONS		
COMPT.	HEIGHT	WIDTH	HEIGHT	WIDTH	DEPTH
L1	31 13/16	13 7/16	38 1/2	20 5/16	19 7/8
L2	23	33 1/4	27 1/2	41 1/2	12 1/8
L3	23	50 1/4	27 1/2	58	12 1/8
L4	48 1/2	38 3/4	56 1/2	45 3/4	26 1/2
L6	32	53	40	59	26 1/2

DOOR OPENINGS			COMPARTMENT DIMENSIONS		
COMPT.	HEIGHT	WIDTH	HEIGHT	WIDTH	DEPTH
R1	31 13/16	33 7/16	38 1/2	40	8 1/2 LOWER 10" 27 1/2 UPPER 26 1/2"
R2	23	33 1/4	27 1/2	41 1/2	26 1/2
R3	23	50 1/4	27 1/2	58	26 1/2
R4	48 1/2	38 3/4	56 1/2	45 3/4	26 1/2
R5	48 1/2	38 3/4	56 1/2	45 3/4	26 1/2
R6	32 1/8	30 7/8	40 1/8	34 3/4	26 1/2

DOOR OPENINGS			COMPARTMENT DIMENSIONS		
COMPT.	HEIGHT	WIDTH	HEIGHT	WIDTH	DEPTH
A1	9 1/8	24 1/2	9 7/8	26	88

TOTAL COMPARTMENT VOLUME - 283.49 CU.FT.

DIMENSIONS SHOWN ON THIS DRAWING ARE APPROXIMATE AND ARE SUBJECT TO MINOR DEVIATIONS DURING CONSTRUCTION.

IN THE EVENT OF A DISCREPANCY BETWEEN THE SUTPHEN SPECIFICATIONS AND DRAWING, THE SUTPHEN SPECIFICATIONS SHALL PREVAIL.

DRAWING IS FOR REFERENCE ONLY. SOME ITEMS PROPOSED MAY NOT BE SHOWN OR NOTED.

CUSTOMER APPROVAL

NAME: _____

TITLE: _____

DATE: _____

REV.	DESCRIPTION	BY	DATE
E	REV-E SHOP ORDER/REFERENCE SHOP ORDER DOCUMENT ON SHARED DRIVE	JML	04/29/2021
D	REV-D SHOP ORDER/REFERENCE SHOP ORDER DOCUMENT ON SHARED DRIVE	JML	01/04/2021
C	REV-C SHOP ORDER/REFERENCE SHOP ORDER DOCUMENT ON SHARED DRIVE	JML	12/04/2020
B	REV-B SHOP ORDER/REFERENCE SHOP ORDER DOCUMENT ON SHARED DRIVE	JML	12/03/2020

DRAWN BY: JLAMBERT

DATE: 10/23/2020

MFG. FACILITY: DUBLIN

DEMO 501

SPH100 AERIAL PLATFORM

DWG. NO.: HS-6940