

COMPT	DOORS	OPENING DIMENSIONS	INSIDE DIMENSIONS	VOLUME
L1	ROLL-UP	23.25"W x 49.50"H	29.75"W x 59.00"H x 17.75"D	18.02 CU. FT.
L2	ROLL-UP	53.25"W x 19.50"H	60.00"W x 28.25"H x 17.75"D	17.41 CU. FT.
L3	ROLL-UP	18.25"W x 49.50"H	24.75"W x 59.00"H x 17.75"D	14.99 CU. FT.
L4	ROLL-UP	43.25"W x 49.50"H	47.25"W x 59.00"H x 17.75"D	28.63 CU. FT.
A1	ROLL-UP	44.50"W x 20.50"H	53.00"W x 29.75"H x 47.75"D	43.57 CU. FT.

COMPT	DOORS	OPENING DIMENSIONS	INSIDE DIMENSIONS	VOLUME
R1	ROLL-UP	23.25"W x 35.00"H	29.75"W x 45.00"H x 22.75"D	17.62 CU. FT.
R2	HINGED	50.00"W x 9.25"H	60.00"W x 14.00"H x 22.75"D	11.05 CU. FT.
R3	ROLL-UP	18.25"W x 35.00"H	22.75"W x 45.00"H x 22.75"D	13.47 CU. FT.
R4	ROLL-UP	43.25"W x 35.00"H	47.25"W x 45.00"H x 22.75"D	27.99 CU. FT.
TOTAL VOLUME				192.75 CU. FT.

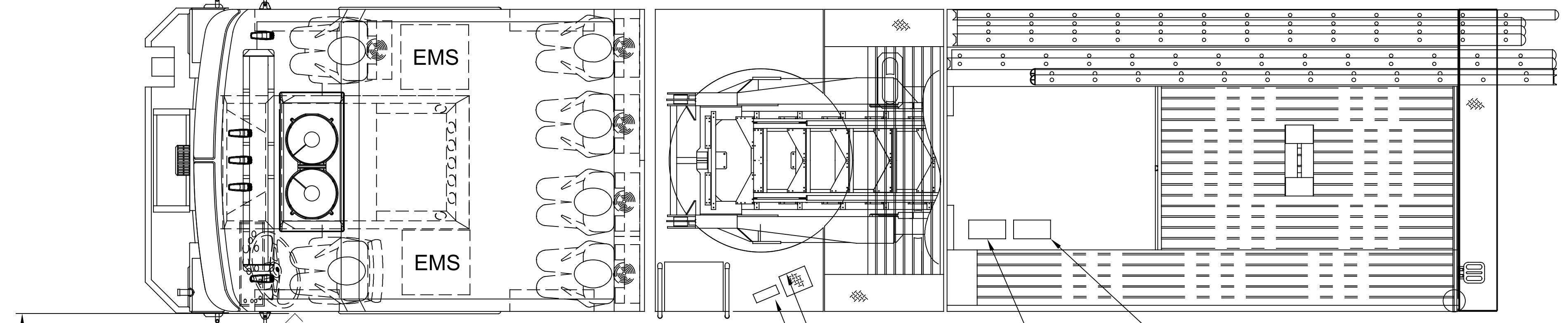

CAB STORAGE COMPARTMENTS				
COMPT	DOORS	OPENING DIMENSIONS	INSIDE DIMENSIONS	VOLUME
OFFICER SEAT RISER	HINGED	15.50"W x 10.50"H	19.00"W x 14.00"H x 13.00"D	2.00 CU. FT.
OVERHEAD STORAGE	HINGED	(2) 37.50"W x 5.5"H	84.00"W x 9.50"H x 16.00"D	7.00 CU. FT.
EMS CABINET, DRIVER SIDE	ROLL-UP		21.00"W x 39.00"H x 22.00"D	10.40 CU. FT.
EMS CABINET, OFFICER SIDE	ROLL-UP		21.00"W x 39.00"H x 18.00"D	8.50 CU. FT.
TRANSVERSE SEAT BOX			18.75"W x 11.00"H x 59.00"D	7.00 CU. FT.
EXTERIOR CAB COMPT, DRIVER	HINGED	11.50"W x 35.00"H	13.00"W x 37.00"H x 24.00"D	6.68 CU. FT.
EXTERIOR CAB COMPT, OFFICER	HINGED	11.50"W x 35.00"H	13.00"W x 37.00"H x 12.00"D	3.34 CU. FT.
TOTAL VOLUME				44.92 CU. FT.

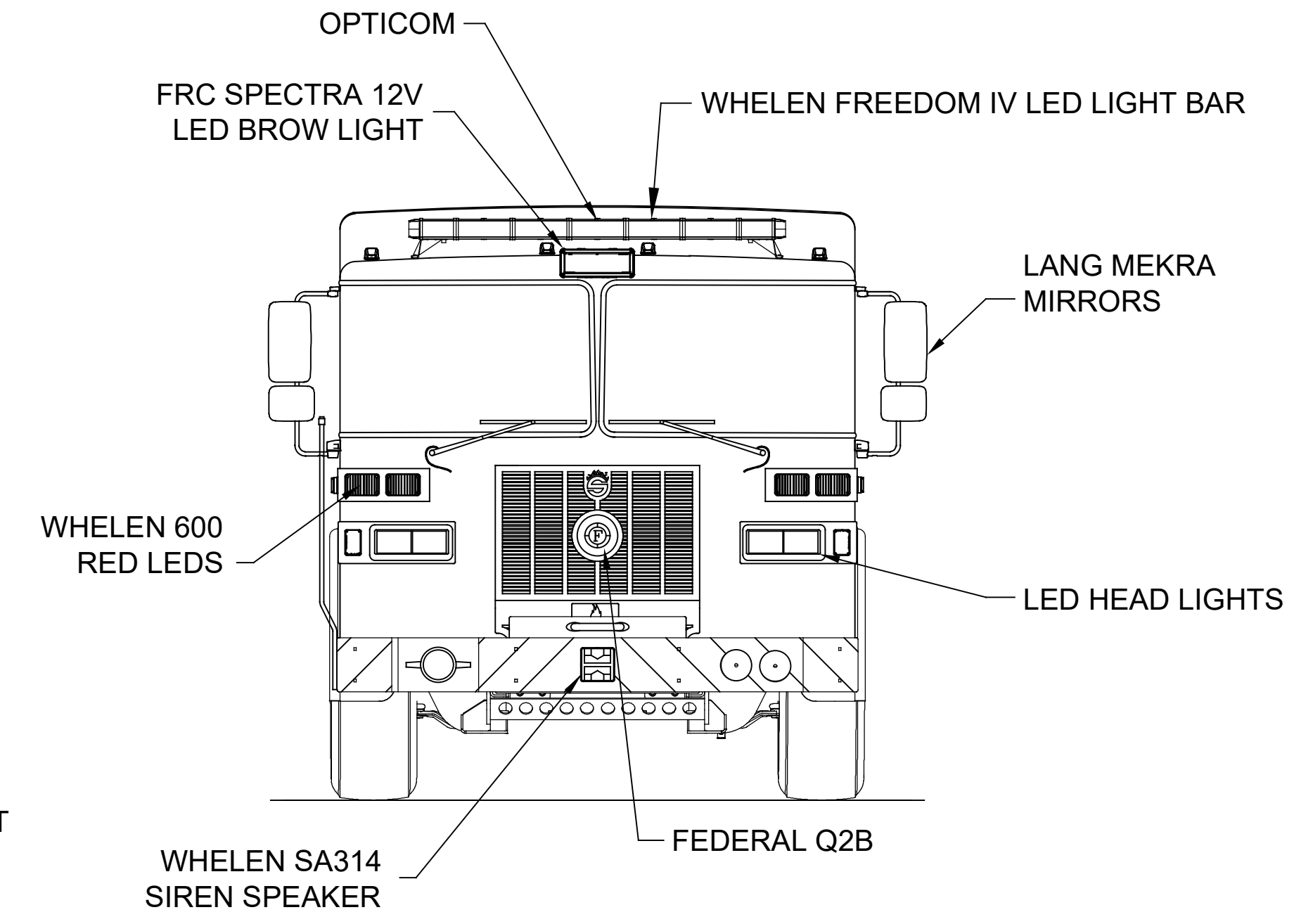
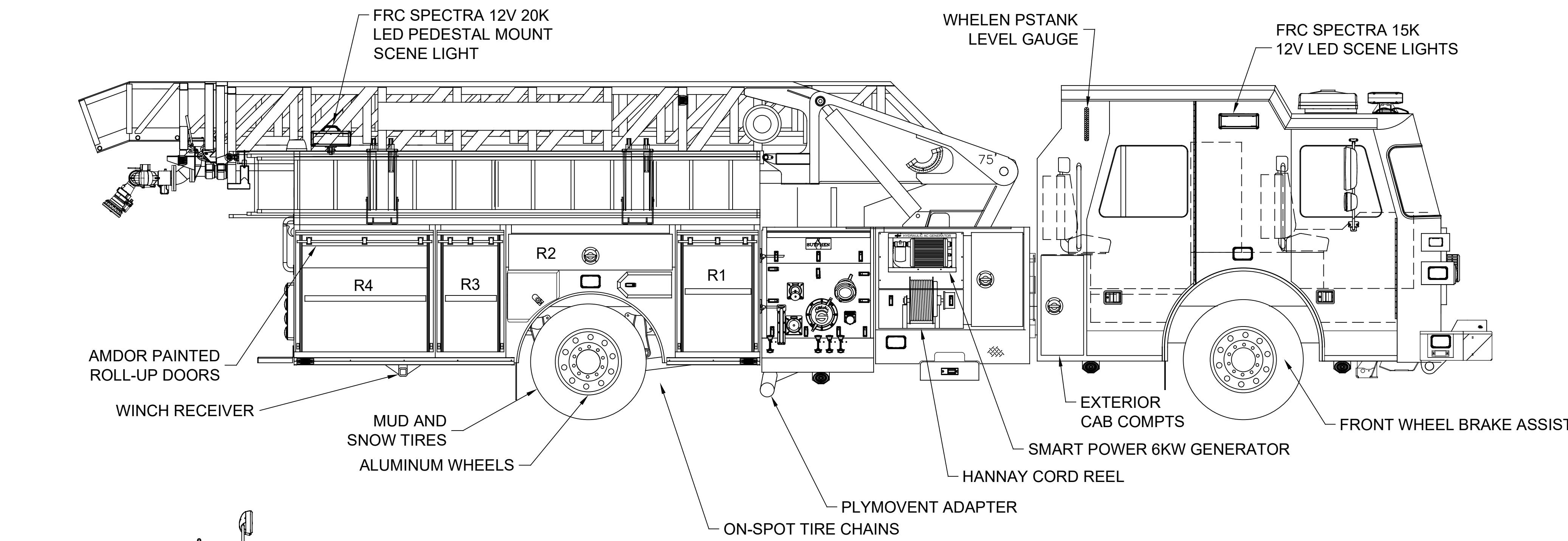
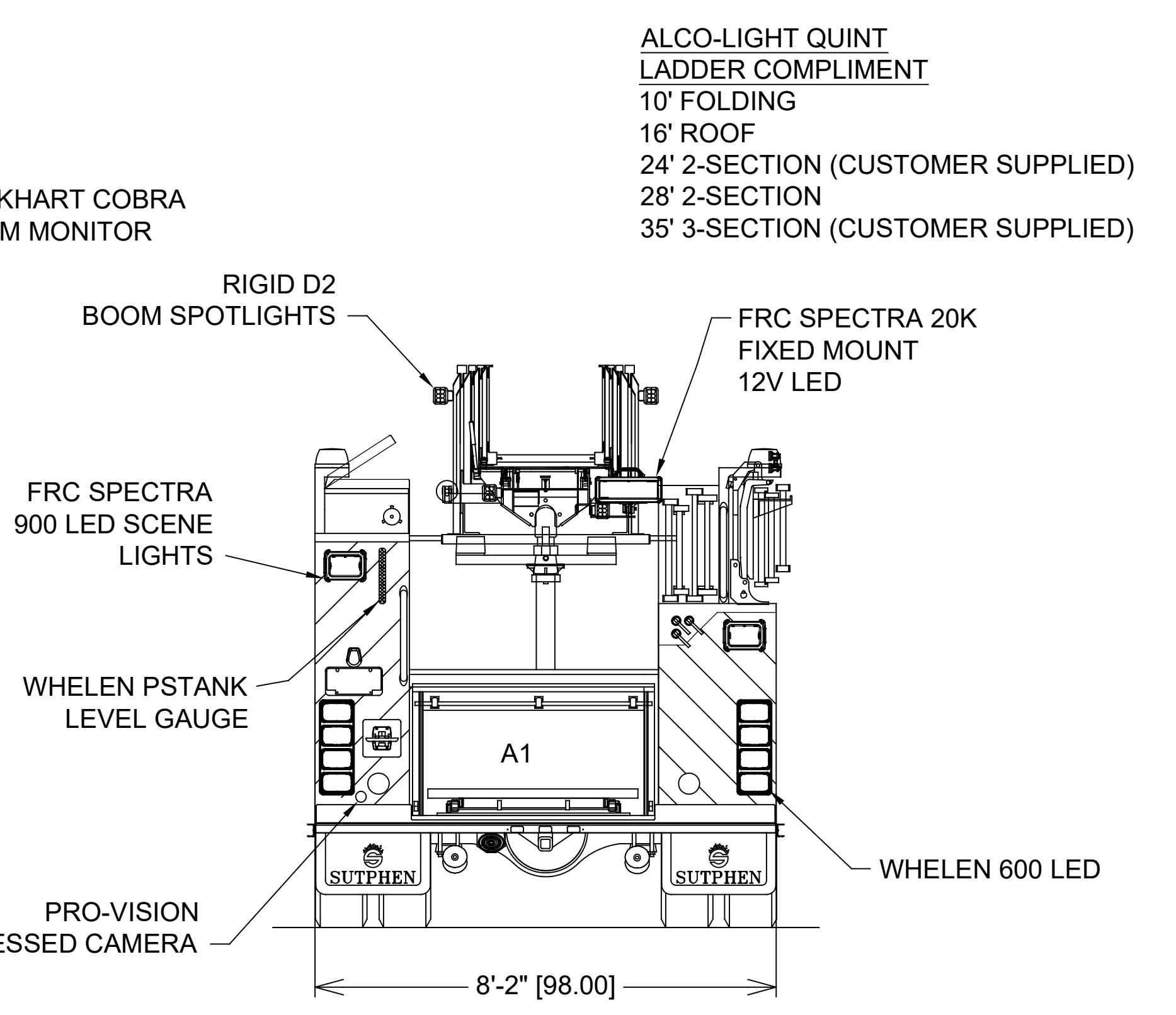
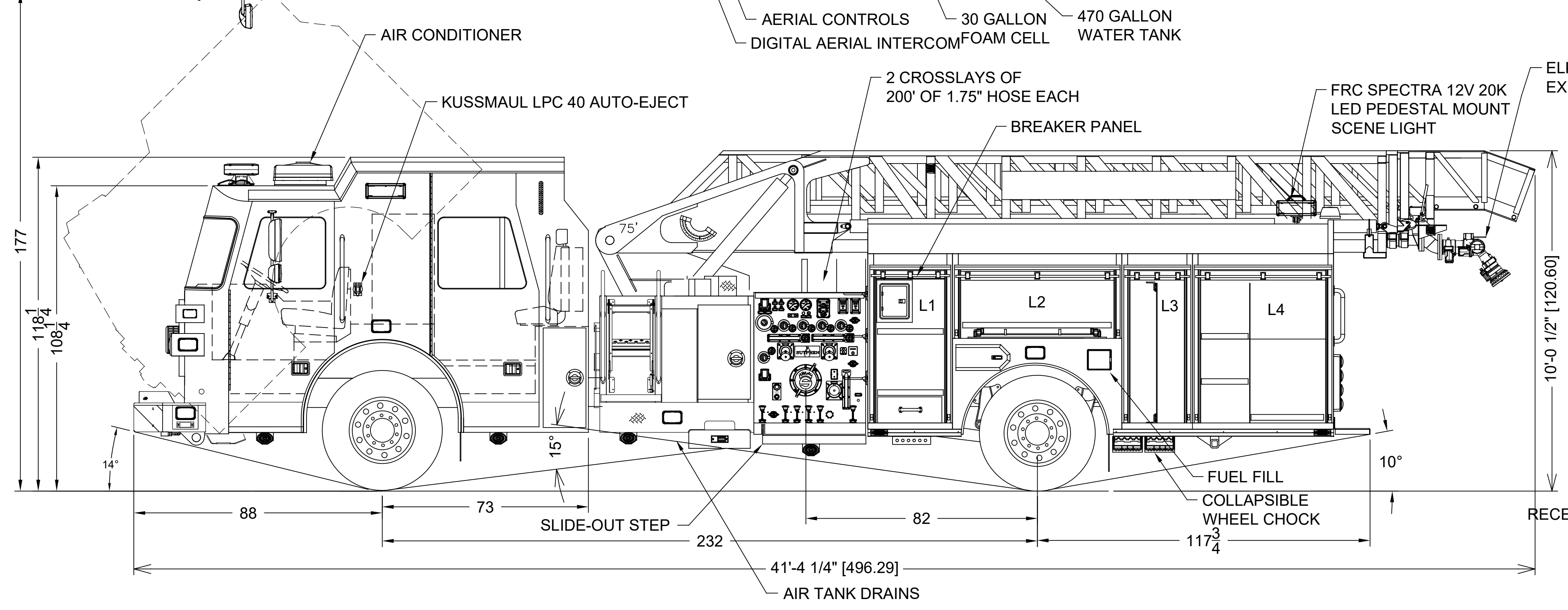

DIMENSIONS SHOWN ON THIS DRAWING ARE APPROXIMATE AND ARE SUBJECT TO MINOR DEVIATIONS DURING CONSTRUCTION.	CUSTOMER APPROVAL		REV.	DESCRIPTION	BY	DATE	DRAWN BY:	SUTPHEN
	NAME:						APF	
IN THE EVENT OF A DISCREPANCY BETWEEN THE SUTPHEN SPECIFICATIONS AND DRAWING, THE SUTPHEN SPECIFICATIONS SHALL PREVAIL.	TITLE:						DATE:	SOUTH CHARLESTON FIRE DEPARTMENT SOUTH CHARLESTON, WV
DRAWING IS FOR REFERENCE ONLY. SOME ITEMS PROPOSED MAY NOT BE SHOWN OR NOTED.	DATE:						11/03/17	
							MFG. FACILITY:	SL75
							HILLIARD	HS-6128

THIS PRINT IS PROVIDED ON A RESTRICTED BASIS AND IS NOT TO BE USED IN ANY WAY DETRIMENTAL TO THE INTEREST OF SUTPHEN CORPORATION.