

- PIKE COMPT.
- (3) PIKE POLE TUBES
- (1) 10' FOLDING
- LADDER CHUTE
- (1) 24' 2-SECT
- (1) 14' ROOF

HOSEBED  
200' OF 2-1/2"  
500' OF 3"  
1,000' OF 5"

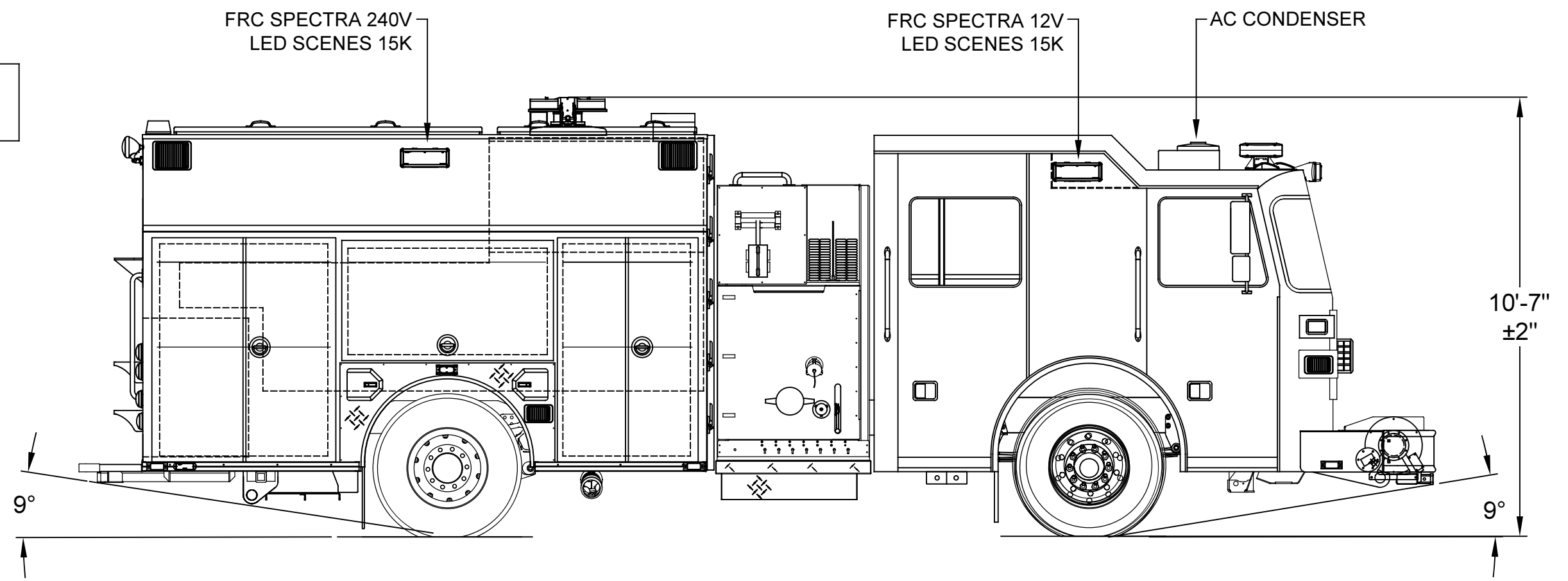

| LEFT SIDE COMPARTMENTATION |         |                    |                                   |              |
|----------------------------|---------|--------------------|-----------------------------------|--------------|
| COMPT                      | DOORS   | OPENING DIMENSIONS | INSIDE DIMENSIONS                 | VOLUME       |
| L1                         | ROLL-UP | 37" w X 56 7/8" h  | 43" w X 66" h X 27 1/4" d         | 42.2 CU. FT. |
| L2                         | ROLL-UP | 57" w X 27 5/8" h  | 61 1/2" w X 36 1/2" h X 27 1/4" d | 32.1 CU. FT. |
| L3                         | ROLL-UP | 50" w X 56 7/8" h  | 53 1/2" w X 66" h X 27 1/4" d     | 52.5 CU. FT. |
| H1                         | LIFT-UP |                    | 162" L X 26" H X 21" W            | 51.1 CU. FT. |

| RIGHT SIDE COMPARTMENTATION |         |                    |   |              |
|-----------------------------|---------|--------------------|---|--------------|
| COMPT                       | DOORS   | OPENING DIMENSIONS | INSIDE DIMENSIONS                           | VOLUME       |
| R1                          | ROLL-UP | 37" w X 56 7/8" h  | 43" w X 66" h X 27 1/4" d (16" d upper)     | 33.7 CU. FT. |
| R2                          | ROLL-UP | 57" w X 27 5/8" h  | 61 1/2" w X 36 1/2" h X 16" d               | 18.6 CU. FT. |
| R3                          | ROLL-UP | 50" w X 56 7/8" h  | 53 1/2" w X 66" h X 27 1/4" d (16" d upper) | 41.6 CU. FT. |
| H2                          | LIFT-UP |                    | 162" L X 26" H X 21" W                      | 51.1 CU. FT. |

| REAR STEP COMPARTMENTS |         |                    |                           |            |
|------------------------|---------|--------------------|---------------------------|------------|
| COMPT                  | DOORS   | OPENING DIMENSIONS | INSIDE DIMENSIONS         | VOLUME     |
| A1                     | ROLL-UP | 37 1/2" w X 31" h  | 40" h X 40" w X 30 1/2" d | 27 CU. FT. |

TOTAL STORAGE: 349.9 CU.FT.

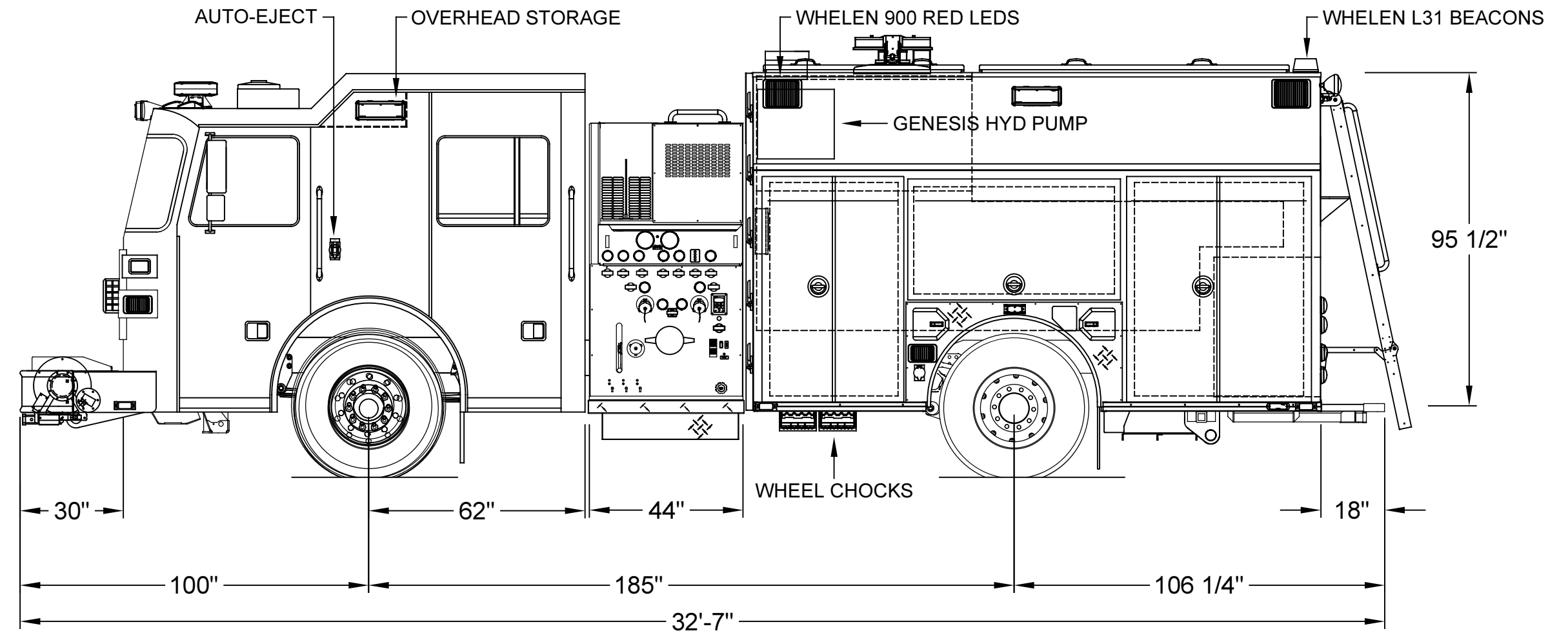
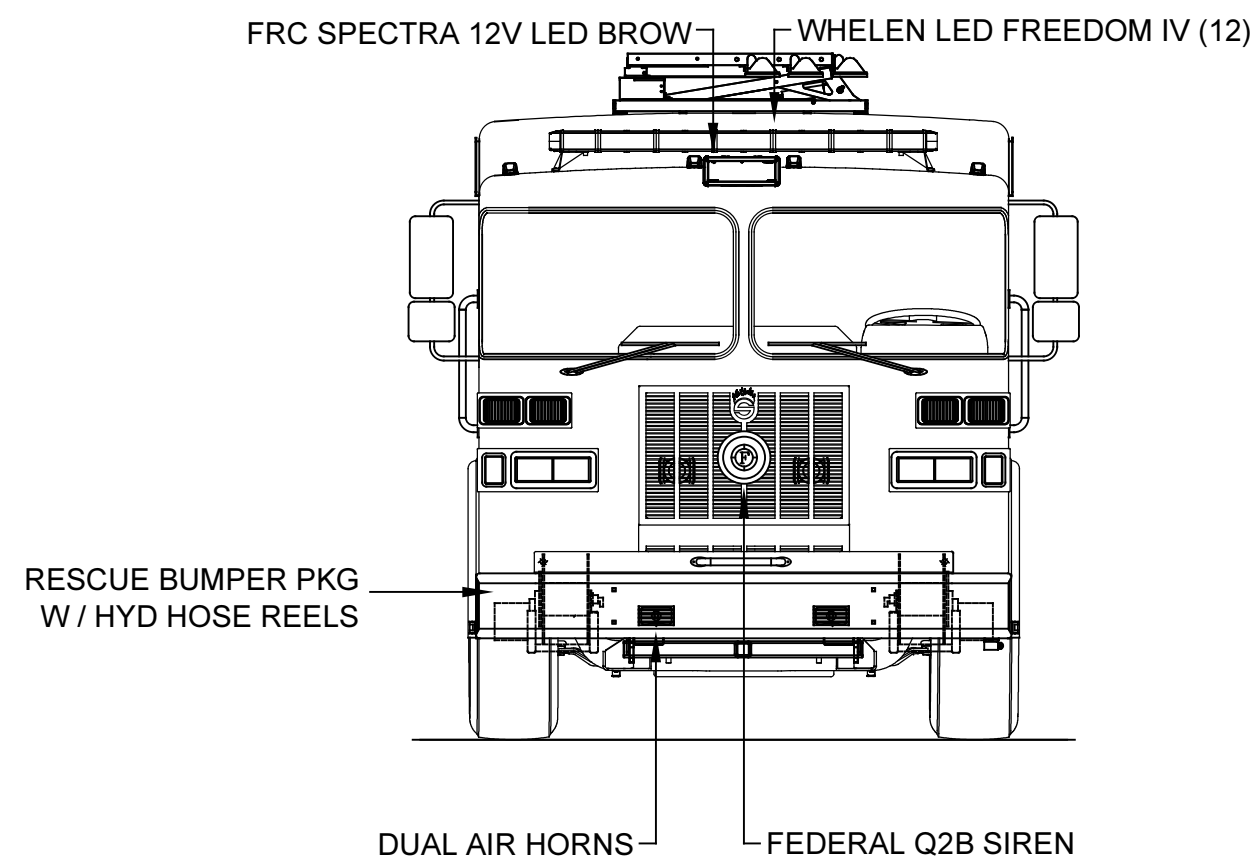
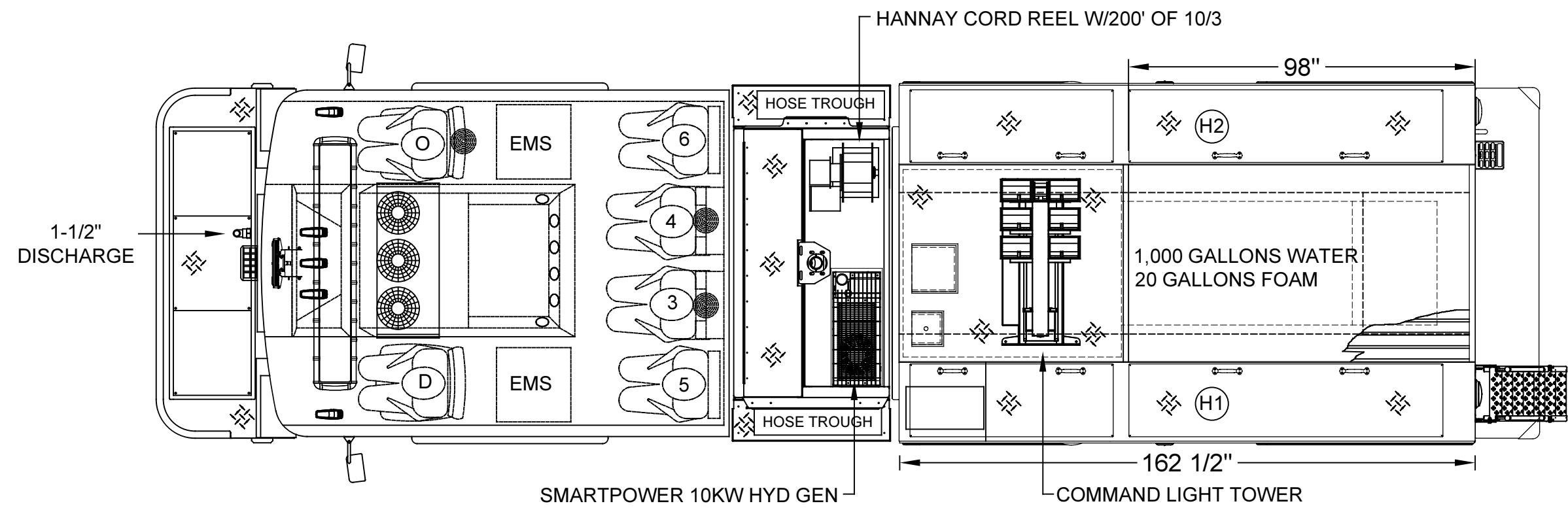

DIMENSIONS SHOWN ON THIS DRAWING ARE APPROXIMATE AND ARE SUBJECT TO MINOR DEVIATIONS DURING CONSTRUCTION.

IN THE EVENT OF A DISCREPANCY BETWEEN THE SUTPHEN SPECIFICATIONS AND DRAWING, THE SUTPHEN SPECIFICATIONS SHALL PREVAIL.

DRAWING IS FOR REFERENCE ONLY. SOME ITEMS PROPOSED MAY NOT BE SHOWN OR NOTED.

**CUSTOMER APPROVAL**

NAME: \_\_\_\_\_

TITLE: \_\_\_\_\_

DATE: \_\_\_\_\_

| REV. | DESCRIPTION  | BY | DATE     |
|------|--|----|----------|
| G    | PRE-FINAL INSPECTION REVISION WITH DRAWING IMPROVEMENTS / UPDATES AND A FEW CLARIFICATIONS | RM | 05/07/18 |
| F    | OUTLET IN REAR FENDER ADDED TO COMPONENT REPORT ; CORRECT LIGHT TOWER MODEL # CALLED OUT   | RM | 04/17/18 |
| E    | INTERIOR CAB DOOR AND FRONT BUMPER CHEVRONS MOVED TO DEALER SUPPLIED                       | RM | 02/07/18 |
| D    | CUSTOMERS HAVE UPGRADED TO AN OUTLAW MODEL HYDRAULIC GENERATOR                             | RM | 02/02/18 |

THIS PRINT IS PROVIDED ON A RESTRICTED BASIS AND IS NOT TO BE USED IN ANY WAY DETRIMENTAL TO THE INTEREST OF SUTPHEN CORPORATION.

DRAWN BY:  
R. MILLER

DATE:  
06/29/17

MFG. FACILITY:  
DUBLIN

**SUTPHEN**

MAD RIVER TWP FIRE DEPARTMENT  
ENON, OH

CUSTOM PUMPER - S6 BODY

DWG. NO.: HS-6093