

LEFT SIDE COMPARTMENTATION				
COMPT	DOORS	OPENING DIMENSIONS	INSIDE DIMENSIONS	VOLUME
L1	ROLL-UP	37" W X 56 7/8" H	43" W X 66" H X 27 1/4" D	40 CU. FT.
L2	ROLL-UP	57" W X 27 5/8" H	61 1/2" W X 36 1/2" H X 27 1/4" D	30 CU. FT.
L3	ROLL-UP	50" W X 56 7/8" H	53 1/2" W X 66" H X 27 1/4" D	55 CU. FT.

RIGHT SIDE COMPARTMENTATION				
COMPT	DOORS	OPENING DIMENSIONS	INSIDE DIMENSIONS	VOLUME
R1	ROLL-UP	37" W X 50 7/8" H	43" W X 66" H X 27 1/4" D (10 1/2" D UPPER)	26 CU. FT.
R2	ROLL-UP	57" W X 21 5/8" H	61 1/2" W X 36 1/2" H X 10 1/2" D	13 CU. FT.
R3	ROLL-UP	50" W X 50 7/8" H	53 1/2" W X 66" H X 27 1/4" D (10 1/2" D UPPER)	43 CU. FT.

REAR STEP COMPARTMENTS				
COMPT	DOORS	OPENING DIMENSIONS	INSIDE DIMENSIONS	VOLUME
A1	ROLL-UP	37 1/2" W X 31" H	40" H X 40" W X 30 1/2" D	27 CU. FT.

TOTAL: 234 CU. FT.

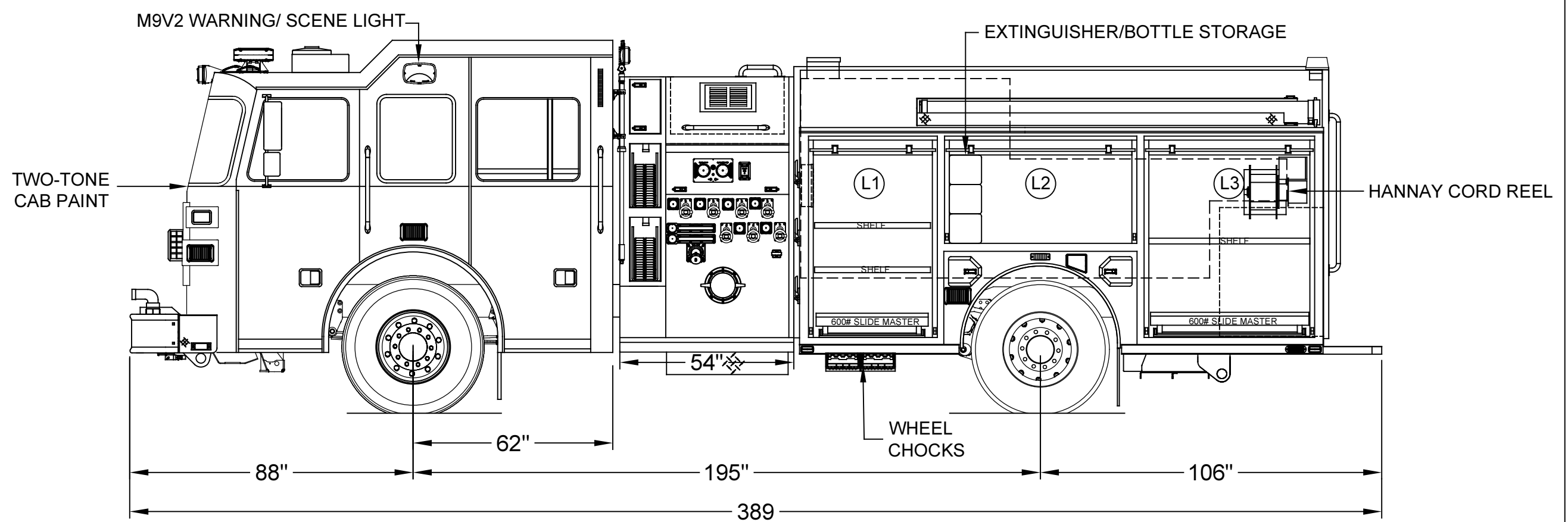
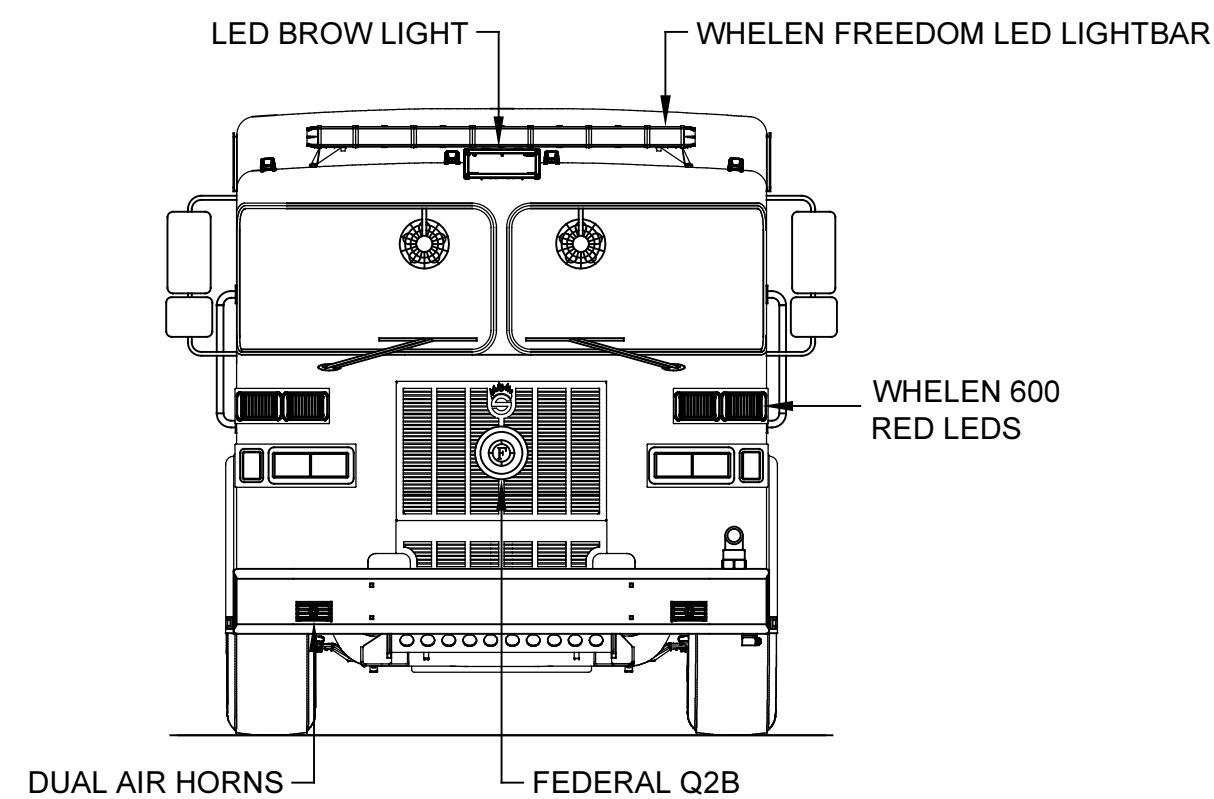
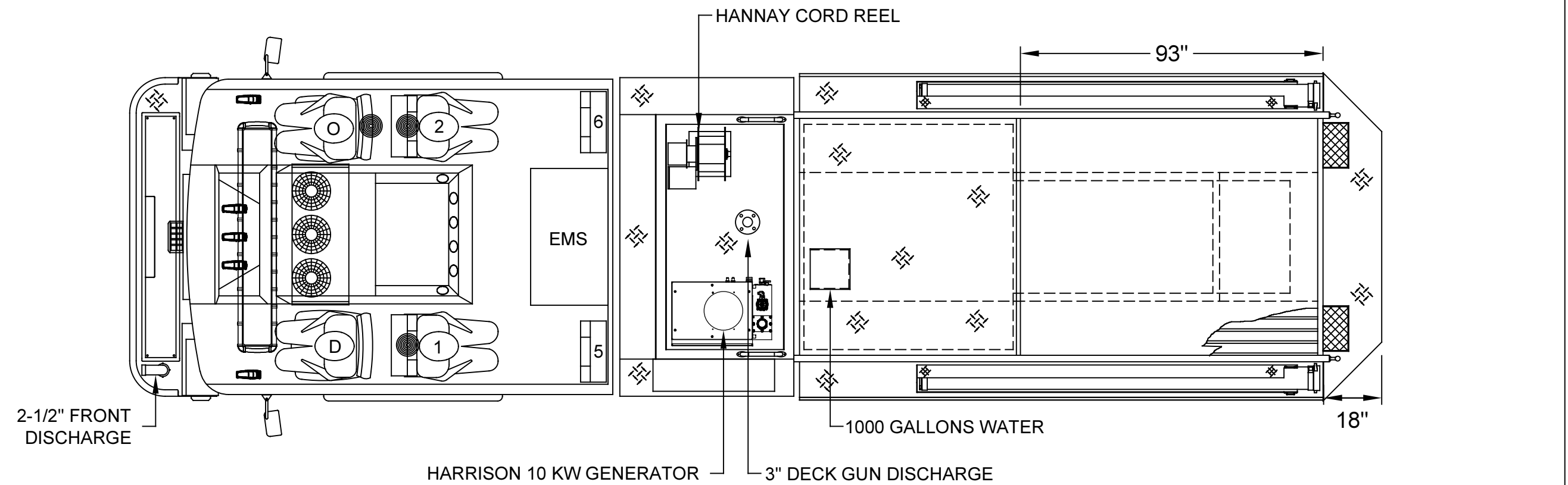

DIMENSIONS SHOWN ON THIS DRAWING ARE APPROXIMATE AND ARE SUBJECT TO MINOR DEVIATIONS DURING CONSTRUCTION.

IN THE EVENT OF A DISCREPANCY BETWEEN THE SUTPHEN SPECIFICATIONS AND DRAWING, THE SUTPHEN SPECIFICATIONS SHALL PREVAIL.

DRAWING IS FOR REFERENCE ONLY. SOME ITEMS PROPOSED MAY NOT BE SHOWN OR NOTED.

CUSTOMER APPROVAL

NAME: _____

TITLE: _____

DATE: _____

REV.	DESCRIPTION	BY	DATE
A	REV-A.SHOP.ORDER	JM	01/19/18

THIS PRINT IS PROVIDED ON A RESTRICTED BASIS AND IS NOT TO BE USED IN ANY WAY DETRIMENTAL TO THE INTEREST OF SUTPHEN CORPORATION.

DRAWN BY:
J.MORGAN

DATE:
08/16/17

MFG. FACILITY:
DUBLIN

SUTPHEN

DEFIANCE FIRE DEPARTMENT
DEFIANCE, OH

CUSTOM PUMPER - PA-12 BODY

DWG. NO.: HS-6088