

LEFT SIDE COMPARTMENTATION				
COMPT	DOORS	OPENING DIMENSIONS	INSIDE DIMENSIONS	VOLUME
L1	SINGLE	23 1/2"w X 62 3/4"h	31 1/2"w X 66"h X 27 1/4"d (10 1/2"d upper 16")	29.7 CU. FT.
L2	LIFT-UP	57 1/2"w X 32 1/4"h	61 1/2"w X 36 1/2"h X 27 1/4"d (10 1/2"d upper 16")	26.5 CU. FT.
L3	DOUBLE	48 1/2"w X 62 3/4"h	53 1/2"w X 66"h X 27 1/4"d (10 1/2"d upper 16")	50.5 CU. FT.

RIGHT SIDE COMPARTMENTATION				
COMPT	DOORS	OPENING DIMENSIONS	INSIDE DIMENSIONS	VOLUME
R1	SINGLE	23 1/2"w X 62 3/4"h	31 1/2"w X 66"h X 27 1/4"d (10 1/2"d upper 33")	22.7 CU. FT.
R2	LIFT-UP	57 1/2"w X 32 1/4"h	61 1/2"w X 36 1/2"h X 10 1/2"d	13.6 CU. FT.
R3	DOUBLE	48 1/2"w X 62 3/4"h	53 1/2"w X 66"h X 27 1/4"d (10 1/2"d upper 33")	38.5 CU. FT.

REAR STEP COMPARTMENTS				
COMPT	DOORS	OPENING DIMENSIONS	INSIDE DIMENSIONS	VOLUME
A1	ROLL-UP	37 1/2"w X 31"h	40"h X 40"w X 30 1/2"d	28.2 CU. FT.

TOTAL STORAGE: 209.7 CU.FT.

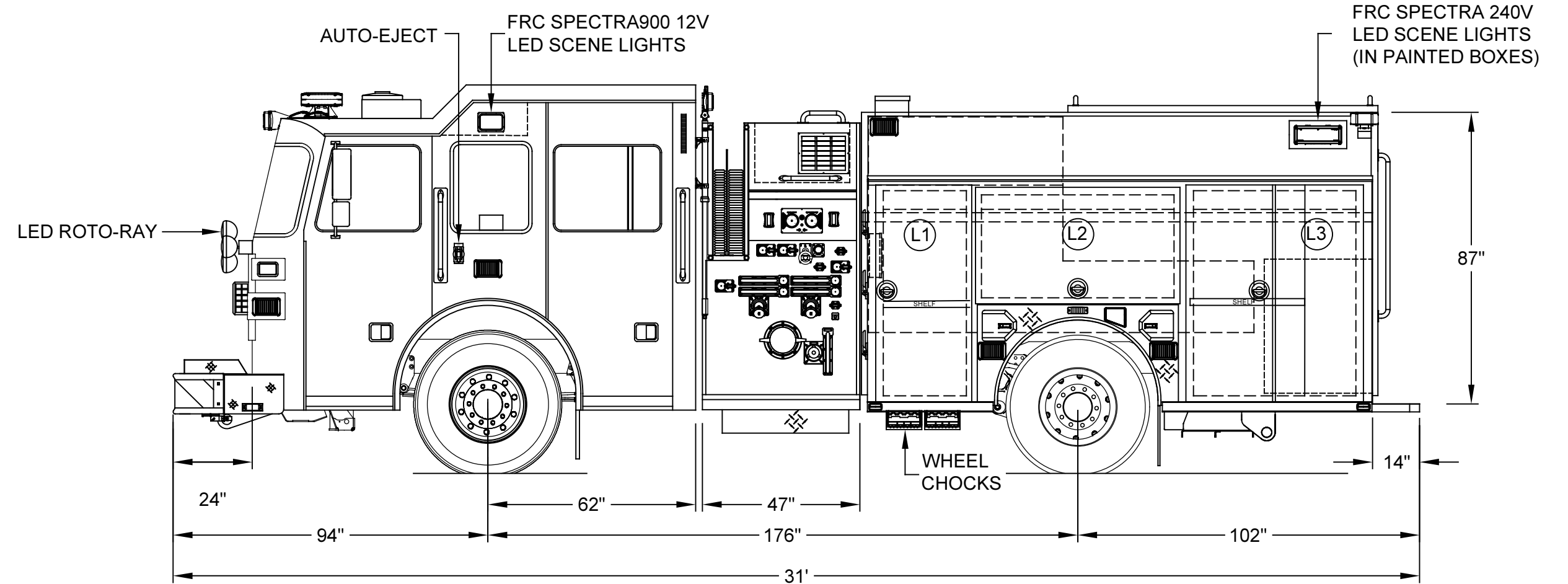
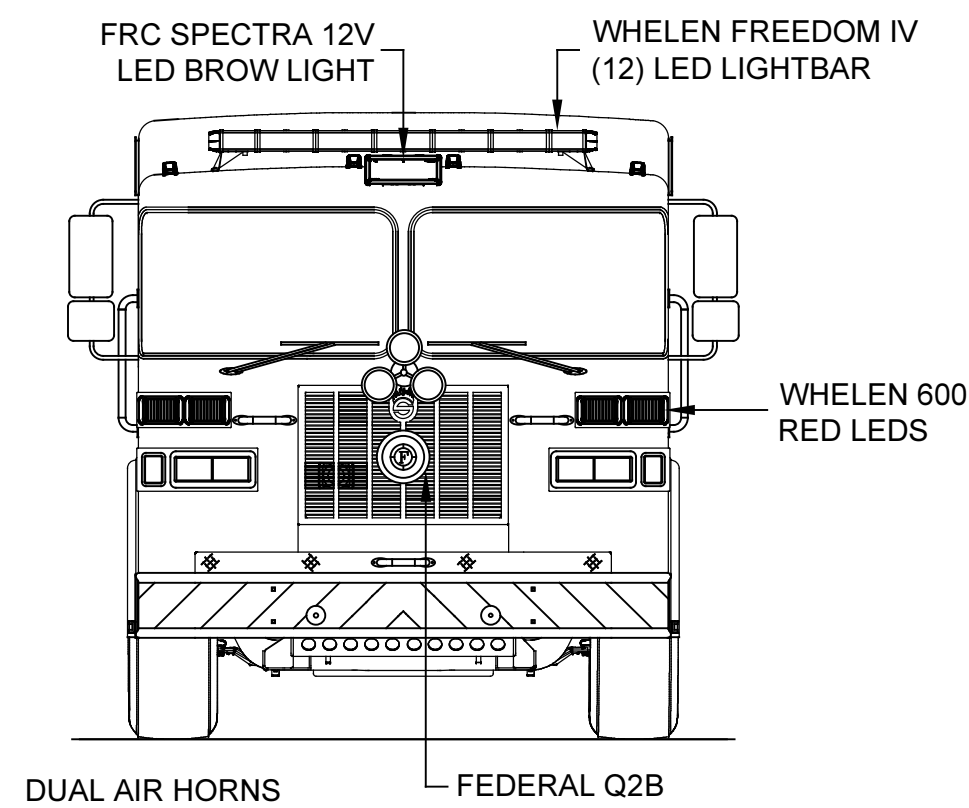
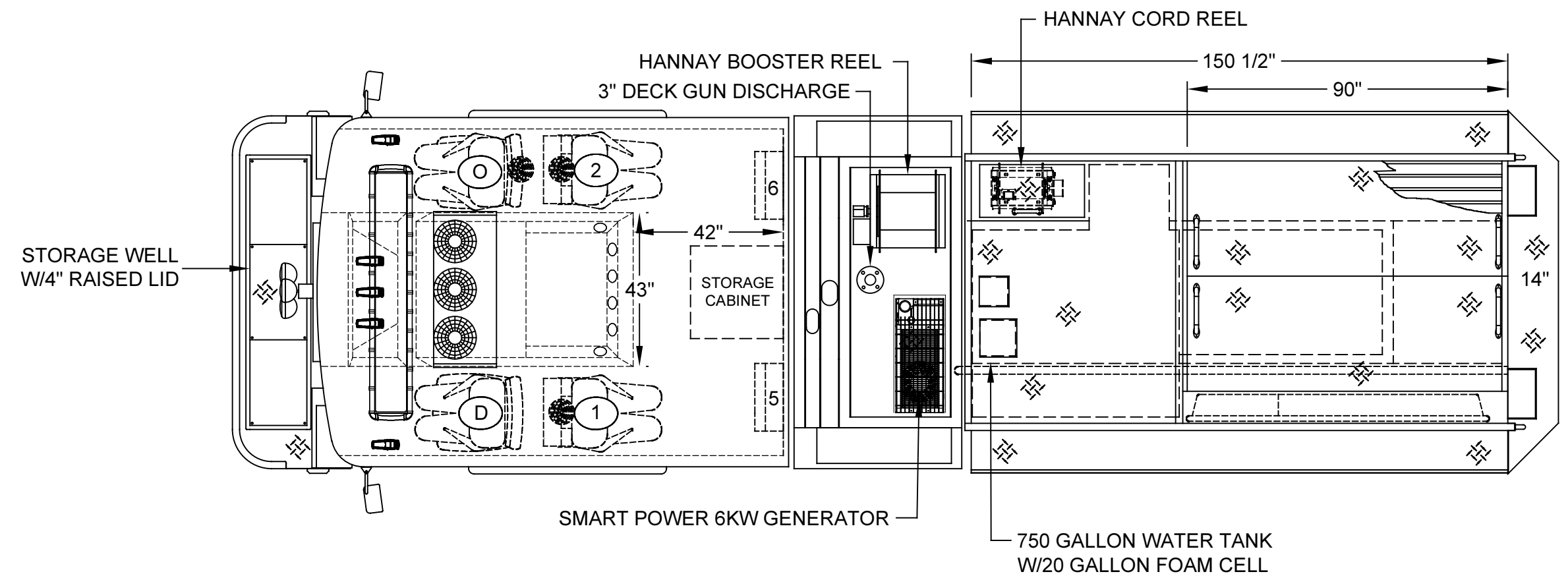

DIMENSIONS SHOWN ON THIS DRAWING ARE APPROXIMATE AND ARE SUBJECT TO MINOR DEVIATIONS DURING CONSTRUCTION.

IN THE EVENT OF A DISCREPANCY BETWEEN THE SUTPHEN SPECIFICATIONS AND DRAWING, THE SUTPHEN SPECIFICATIONS SHALL PREVAIL.

DRAWING IS FOR REFERENCE ONLY. SOME ITEMS PROPOSED MAY NOT BE SHOWN OR NOTED.

CUSTOMER APPROVAL

NAME: _____

TITLE: _____

DATE: _____

REV.	DESCRIPTION	BY	DATE
C	SHELVING	JM	05/07/2018
B	REV-B SHOP ORDER	JM	12/21/2017

THIS PRINT IS PROVIDED ON A RESTRICTED BASIS AND IS NOT TO BE USED IN ANY WAY DETRIMENTAL TO THE INTEREST OF SUTPHEN CORPORATION.

DRAWN BY:
J.MORGAN

DATE:
08/09/2017

MFG. FACILITY:
DUBLIN

WHITEHALL DIVISION OF FIRE
WHITEHALL, OH

CUSTOM PUMPER - PA-02 BODY

DWG. NO.: HS-6055