

Left Side Compartmentation				
Compt	Doors	Opening Dimensions	Inside Dimensions	Volume
L1	Roll Up	23x32	30x36x24.25	15.2 CU FT
Right Side Compartmentation				
Compt	Doors	Opening Dimensions	Inside Dimensions	Volume
R1	Roll Up	44x32	51x36x24.25	25.3 CU FT
R2	Roll Up	23x32	30x36x24.25	15.2 CU FT
Total Volume				55.6 CU Ft

Hale Side Kick 500 GPM PTO
Water Tank Capacity 2000 gal

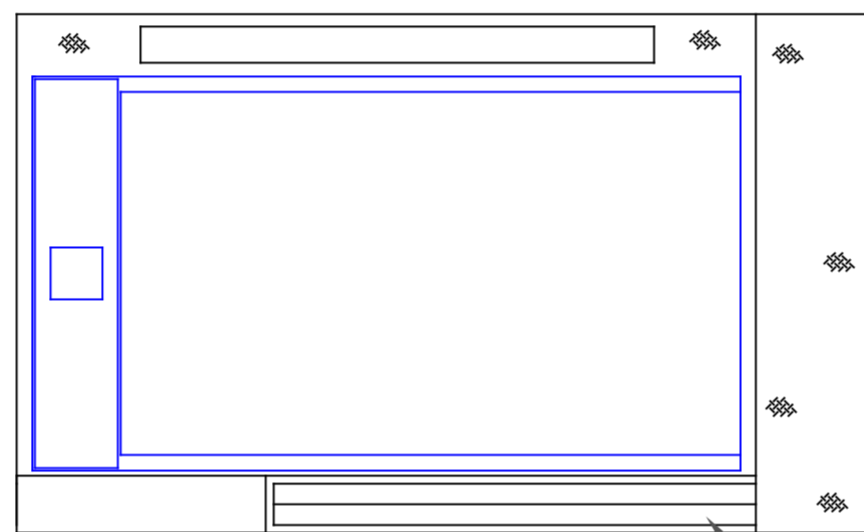

(2) 200ft of 1.75" Crosslays Single Stacked

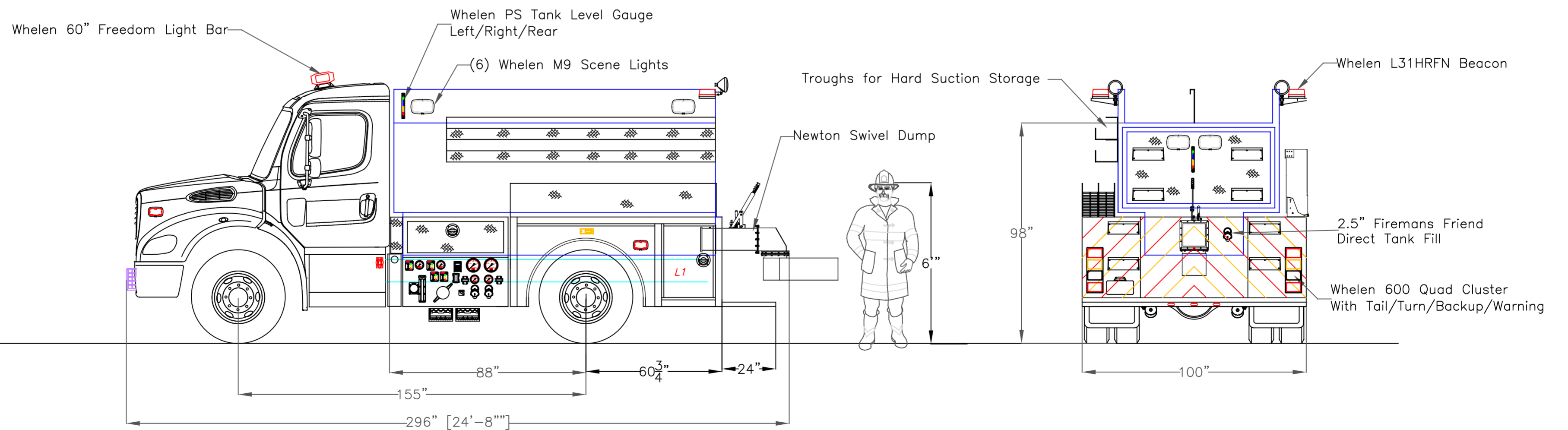

DIMENSIONS SHOWN ON THIS DRAWING ARE APPROXIMATE AND ARE SUBJECT TO MINOR DEVIATIONS DURING CONSTRUCTION.

IN THE EVENT OF A DISCREPANCY BETWEEN THE SUTPHEN SPECIFICATIONS AND DRAWING, THE SUTPHEN SPECIFICATIONS SHALL PREVAIL.

DRAWING IS FOR REFERENCE ONLY. SOME ITEMS PROPOSED MAY NOT BE SHOWN OR NOTED.

CUSTOMER APPROVAL

NAME: _____

TITLE: _____

DATE: _____

REV.	DESCRIPTION	BY	DATE
A	Updated to Reflect Shop Order	JVG	5-25-2017

THIS PRINT IS PROVIDED ON A RESTRICTED BASIS AND IS NOT TO BE USED IN ANY WAY DETRIMENTAL TO THE INTEREST OF SUTPHEN CORPORATION.

DRAWN BY: S.DORFMAN

DATE: 1/30/17

MFG. FACILITY: SUTPHEN EAST LAKE ARIEL, PA

SUTPHEN EAST
55 INNOVATION DRIVE
LAKE ARIEL, PA 18436
1-844-776-2889

Lexington County Fire Services
Lexington, SC

Commercial Stainless Wetside Tanker
HS 6019-6020