

Left Side Compartmentation				
Compt	Doors	Opening Dimensions	Inside Dimensions	Volume
L1	Roll Up	43x26	50x36x24.25	25.3 CU FT
L2	Roll Up	28x26	35x36x24.25	17.7 CU FT
L3	Roll Up	23x26	30x36x24.25	15.2 CU FT
Right Side Compartmentation				
Compt	Doors	Opening Dimensions	Inside Dimensions	Volume
R1	Roll Up	43x26	50x36x24.25	25.3 CU FT
R2	Roll Up	28x26	35x36x24.25	17.7 CU FT
R3	Roll Up	23x26	30x36x24.25	15.2 CU FT
Total Volume				116.2 CU Ft

Hale Qmax 1500 single stage
 Water Tank Capacity 2000 gal
 Foam Tank Capacity 20 gal

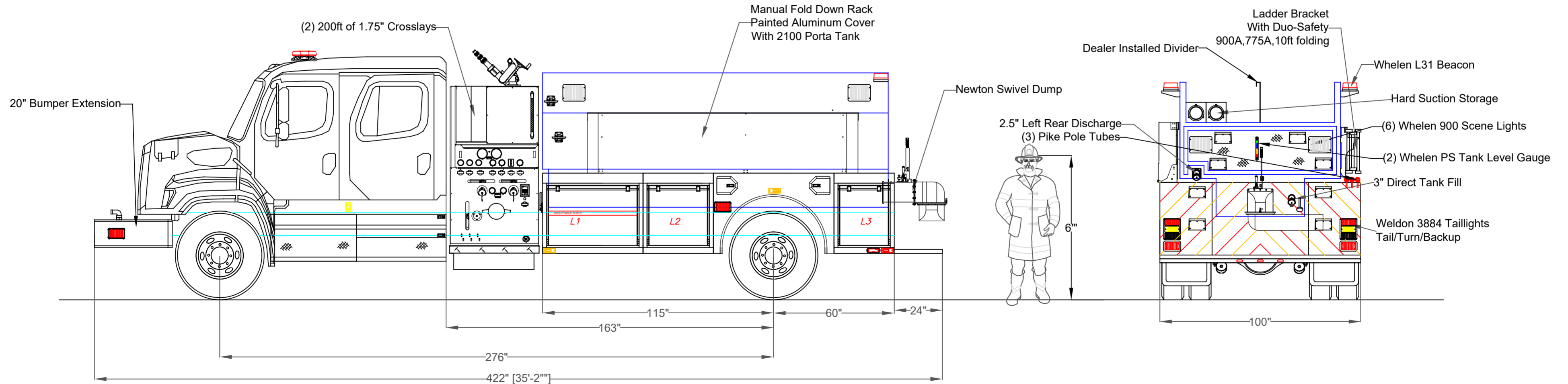

DIMENSIONS SHOWN ON THIS DRAWING ARE APPROXIMATE AND ARE SUBJECT TO MINOR DEVIATIONS DURING CONSTRUCTION.	CUSTOMER APPROVAL		REV.	DESCRIPTION	BY	DATE	DRAWN BY:	SUTPHEN EAST 55 INNOVATION DRIVE LAKE ARIEL, PA 18436 1-844-776-2889
	NAME:						J. Gordon	
IN THE EVENT OF A DISCREPANCY BETWEEN THE SUTPHEN SPECIFICATIONS AND DRAWING, THE SUTPHEN SPECIFICATIONS SHALL PREVAIL.	TITLE:						DATE:	Homer Township Fire Protection Lockport, IL
DRAWING IS FOR REFERENCE ONLY. SOME ITEMS PROPOSED MAY NOT BE SHOWN OR NOTED.	DATE:						11/10/2017	Commercial Wetside Tanker
THIS PRINT IS PROVIDED ON A RESTRICTED BASIS AND IS NOT TO BE USED IN ANY WAY DETRIMENTAL TO THE INTEREST OF SUTPHEN CORPORATION.							MFG. FACILITY:	DWG. NO.:
							SUTPHEN EAST LAKE ARIEL, PA	HS 6178